

PRODUCT MANUAL

E1 Single Speed Electric Motor Unit, 12V & 24V

To Suit Self-Tailing Winch Sizes 46,50



FOR USE WITH

- RA2046001300
- RA2046001400
- RA2046011300
- RA2046011400
- RA2046211300
- RA2046211400
- RA2050001300
- RA2050001400
- RA2050011300
- RA2050011400
- RA2050211300
- RA2050211400

Serial No.: PS _____

Winch versions:

46 (V.4.0)

50 (V.1.0)

CONGRATULATIONS

You have purchased a high quality ANDERSEN Stainless Steel Winch™. It is a result of more than 60 years of experience and expertise in producing winches for sailboats. This winch offers a high level of performance and functionality, and will provide many years of safe and easy sail handling.

CONTENTS

Motor unit included components	3
Required installation tools and supplies	3
Assembly exploded view	4
Parts list	5
Installation instructions	6-9
Wire, circuit breaker & battery capacity requirements	9
Electrical connection diagram	10
Troubleshooting	11-12
Service & maintenance	13
Installation dimensions – Sizes 46 & 50	14
Drilling template – Sizes 46 & 50	15
Safety notices	16
Worldwide distribution and service	18
Warranty	18

Please read this product manual & the relevant winch manual fully before installation or operation.

FEATURES

- Highest quality winch featuring a stainless steel drum for ultimate durability and style, vertical Power Ribs™ for maximum grip and minimum rope wear, and superior engineering for reliability, long service life and low maintenance.
- Easy to install and service. The motor unit has internal controller and contactors so electrical connection is simple. The winch can be serviced without removing it from the deck, independent of the motor unit.
- Illuminated "intelligent" push button with integrated LED to indicate system power on, and in conjunction with the controller will flash status codes that assist with trouble shooting.
- High quality European engineered and manufactured motor, with matched gearbox for optimal speed and load capacity.
- Unrivalled levels of monitoring and protection including: Integrated Overload Protection, Thermal Overload Protection, Accidental Start Protection, Low Voltage Detection, Continuous Run Time Limiting.
- The motor unit can be rotated relative to the winch to suit restricted under-deck space (8 positions at 45° increments)
- 2 speed manual winch operation is always possible by simply inserting a standard winch handle.

INCLUDED

Included in your E1 Electric Motor Kit:

- Motor unit
- Gear wheel [4]
- Push button incl. 500 mm (19 5/8") control cable [A1]
- Push button Gasket [A2]
- 3 pcs. #6 x 19 mm screws [A9]
- Eye-bolt M6 [A6]
- 4 mm Allen key [A4]
- 5 mm Allen key [A5]
- Pin spanner (5 mm pins) [A8]
- Product manual [A10]
- Drilling template [A3]
- Application sticker set [A7]

Numbers in [] above and in instructions refer to the item number in the parts list, see page 4,5

REQUIRED

Tools & fasteners required for installation:

- Phillips head screwdrivers - #1 & #2
- 4 mm Allen key (included)
- 5 mm Allen key (included)
- Pin spanner, 5 mm pins (included)
- Ø8.5 mm (11/32") drill
- Ø82 mm (3 1/4") hole-saw, or jigsaw
- 5 pcs. M8 (5/16") bolt and nut (length as required for deck thickness)
- 5 pcs. large diameter M8 (5/16") ID washers or backing plate (to match drilling template)
- 13 mm AF spanner for M8 Nyloc nuts, or 1/2" AF spanner for 5/16" Nyloc nuts
- Solvent (white spirits/mineral spirits) - to clean deck etc prior to applying sealant
- Sealing compound
- Ø3 mm (1/8") drill
- Ø25 mm (1") drill or hole saw
- Wire crimping tool/pliers
- Marine grade electrical power wire with Ø8 mm terminals (see table page 9)
- Circuit breaker/fuse; available separately (see page 5 and table page 9)
- Cable fastening clips

EXPLODED VIEW

46/50 ST E1 SINGLE SPEED 12V/24V

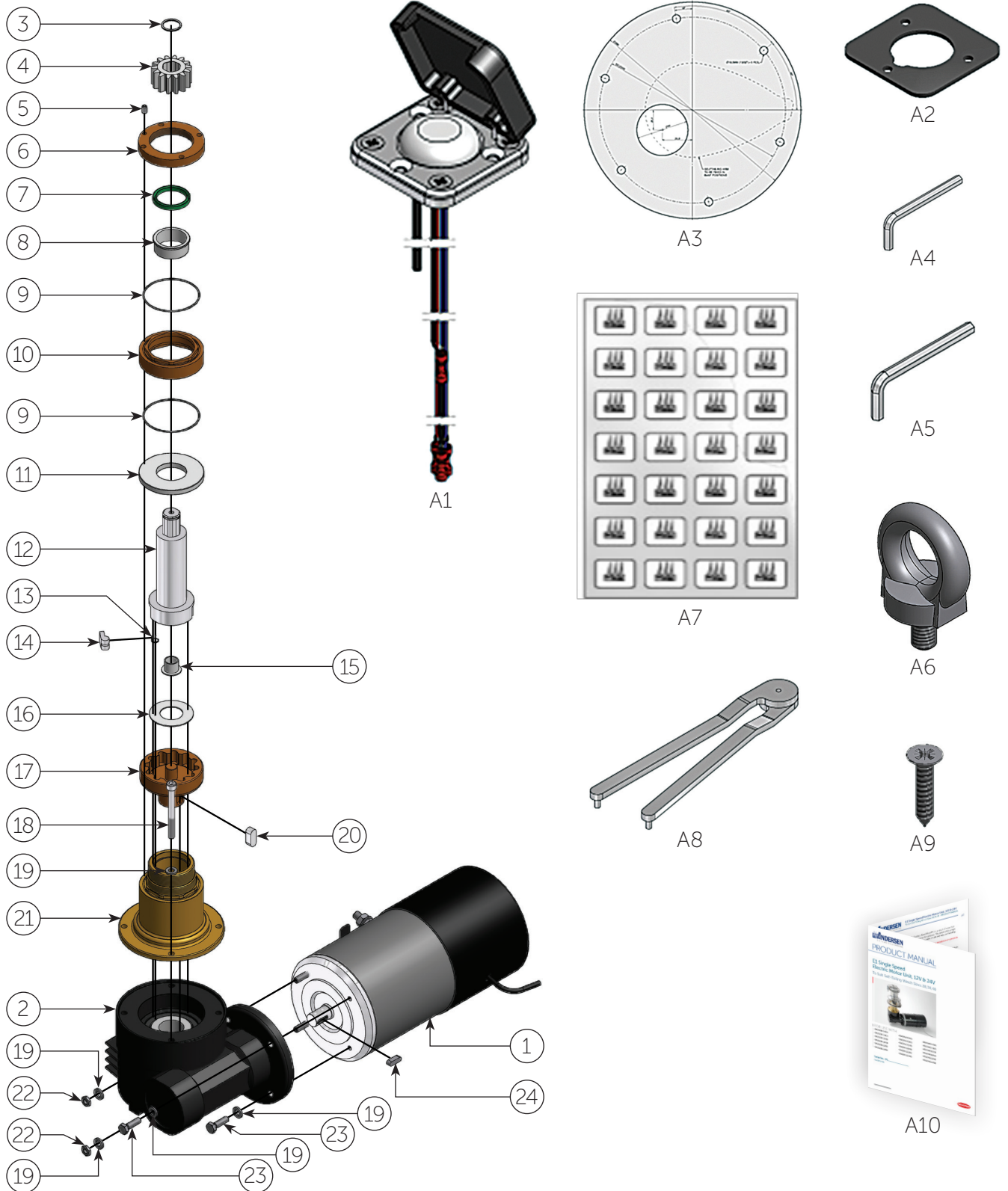

* When supplied as an E1 Electrical Motorised Winch, this gear wheel will already be fitted inside the winch. The gear wheel has a hexagonal section that protrudes from the winch base to engage in the motor unit drive shaft. When supplied as an E1 Electric Conversion Kit only, this gear wheel is supplied separately and must replace the existing gear wheel in the winch - see pages 6-9 for instructions.

PARTS LIST

46/50 ST E1 SINGLE SPEED 12V/24V

ITEM NO.	QTY	DESCRIPTION	PART. NO.
1	1	Motor E1 1000W 12V, incl. controller	777400
1	1	Motor E1 1000W 24V, incl. controller	777410
2	1	Gear box VF 49, i=28 P71 B14	776210
3	1	Circlip	RD829670
4	1	Gear wheel	584601
5	1	Grub screw	DIN916-A4-M5X8
6	1	Clamping ring	584510
7	1	Sealing ring	RD100169
8	1	Plain bearing	823100
9	2	O-Ring	RD100074
10	1	Distance ring	584550
11	1	Stop ring	775890
12	1	Drive shaft	821110
13	2	Spring	713300
14	2	Pawl	713200
15	1	Plain bearing	RD100439
16	1	Washer	835000
17	1	Ratchet gear wheel	775860
18	8	Screw	DIN912-A4-M6X55
19	8	Washer	DIN125-A4-ø6,4
20	1	Key	DIN6885-A4-7X20
21	1	Driveshaft housing	775850
22	2	Nut	DIN439-A4-M6
23	2	Screw	DIN933-A4-M6X20
24	1	Key	DIN6885-A4-5x5x16
A1	1	Push button with plastic cover	RA582000
A2	1	Push button gasket	735050
A3	1	Drilling template 46/50 ST E1	RD100212
A4	1	Allen key 4mm	593200
A5	1	Allen key 5mm	592800
A6	1	Eye bolt M6	RD100896
A7	1	Push button labels	RD100029
A8	1	Pin spanner, Ø5mm pins	RD738000
A9	3	Screw #6 x 19mm	RD100025
A10	1	Product Manual	710472

RELATED ITEMS - Sold separately

0		Push button, with St/St cover	RA582010
0		Push button, with St/St cover with hole	RA582020
0		Circuit breaker 150Amp (suits 46/50 ST E1 12V)	RA590150
0		Circuit breaker 70Amp (suits 46/50 ST E1 24V)	RA590070

I INSTALLATION INSTRUCTIONS

I STEP 1 - Positioning the winch and motor unit

- Position the winch drilling template [A3] in the required position on the deck, ensuring that there is adequate flat space for the deck plate/ winch base.
- The 46 & 50 ST winches have the option of eight different self-tailing arm positions as indicated on the drilling template (refer page 15).
- Considering the product dimensions, shown on page 14, check that there is adequate space below deck for the motor unit. You may choose to drill a small pilot hole to indicate the position of the center of the drive shaft, to assist with this.

***Note:** *The motor unit can be installed in eight positions around the center of the drive shaft (i.e. at 45° increments), to facilitate fitting the motor unit into restricted under-deck cavities. See page 14 for the minimum motor offset dimensions at the various positions. Placing the winch base on the motor unit in the various positions prior to installation can assist with visualising the motor position options.*

***Note:** *To ensure the correct functioning of the winch, it should be positioned with the correct line entry angle of 3-8° below horizontal. Refer to the winch product manual for details of correct line entry angle and self-tailing arm positioning.*

I STEP 2A

- Remove winch self-tailing arm screws using 4mm Allen key [A4].
- Lift self-tailing arm and drum off the base/stem of the winch.
- Remove 6 x M6 screws from base of winch stem with 5mm Allen key [A5].
- Lift stem off base of winch and place aside.
- Remove rubber shut-off disc from base of winch.

I STEP 2B - Fitting the winch base

- After it has been confirmed that there is adequate space for the winch above deck, and for the motor unit below deck;
- Drill Ø8.5mm holes for the M8 winch base mounting bolts as per the drilling template [A3]. Drill Ø11/32" holes if 5/16" bolts are being used.
- Drill or cut a Ø82mm (3 1/4") hole for motor drive shaft housing as per the drilling template.

***Note:** *Clean the deck hole before attempting to install the motor so that the motor flange does not catch splinters of fiberglass or wood when being inserted through the deck. Clean the deck with a suitable solvent to ensure the sealant can adhere properly.*

- Apply sealant to the deck where the winch base will be fitted. For aluminium boats use a galvanic isolating ring/gasket.
- Fit the winch base to the deck using appropriate length M8 (or 5/16") bolts, large backing washers or plate, and Nyloc nuts.
- Assemble the winch in reverse order to the disassembly/removal.

INSTALLATION INSTRUCTIONS

STEP 3

***Note:** It is extremely important that the motor is aligned correctly with the winch. Non-aligned motors will be noisy and gear wear will be accelerated.

***Note:** It is important that two or more people are involved with Step 3.

- Remove clamping ring [6] from drive shaft housing [21] of motor unit.
- Fit the supplied M6 eye bolt [A6] to the top of the motor drive shaft [12] and attach a strong rope to facilitate lifting the motor unit up into position through the hole in the deck, winch base and clamping ring as shown below.
- Using the rope, raise the motor unit so that the drive shaft protrudes through the large hole in the deck and winch base. A lifting device is recommended when raising the motor unit.
- Rotate the motor unit into the required position to suit the under deck cavity, ensuring that the motor is aligned properly – The protruding octagonal detail on the drive shaft housing [16] flange must fit snugly into the octagonal recess in the winch base to allow the motor top flange to fit flush with the underside of the winch base (refer to diagrams below).

***Note:** Ensure that the O-ring [9] on top of the drive shaft housing [21] is in place in its groove.

- Insure that the locking grub screw [5] in the clamping ring [6] is not protruding beyond the upper surface of the clamping ring, when fitting the clamping ring.
- Fit and securely tighten the clamping ring [6] using the pin spanner [A8] provided.
- Tighten the locking grub screw [5] when the clamping ring [6] is securely in place.

***Note:** Do not use a sealant between the flange and winch base. An O-ring insures a waterproof connection. Extra waterproofing can be achieved by applying sealant to the top of the winch base around the clamping ring after installation (make sure no sealant comes onto the sealing ring [7]).

Incorrect mating of drive shaft housing top flange with underside of winch base

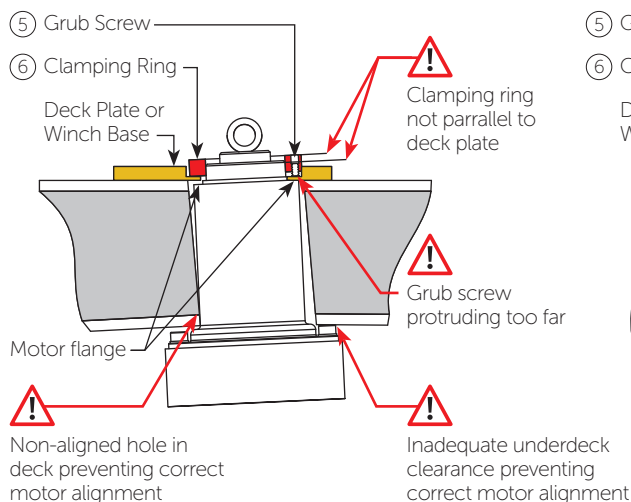

Correct mating of drive shaft housing top flange with underside of winch base

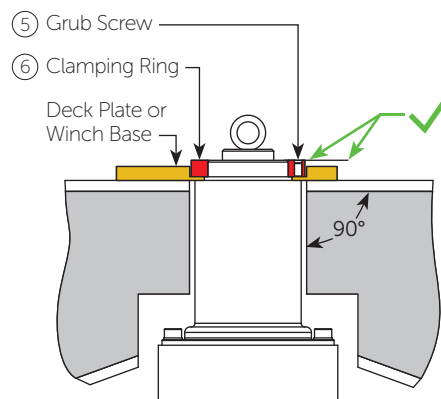

Motor unit lifting eye bolt



INSTALLATION INSTRUCTIONS

STEP 4

***Note:** The push button [A1] requires 25mm depth clearance the behind mounting surface. The push button is supplied with 500 mm (19 5/8") of cable and the motor unit with 1400 mm (55 3/16") of control cable. If the push button to motor unit requires more than 1500 mm (59") of cable you will need to provide your own extension cabling.

- Select the desired position for the push button [A1].
- Drill a $\text{Ø}19$ mm (3/4") hole at the center of the push button location and a 5mm (3/16") hole immediately beside it for the breather tube. Or drill a $\text{Ø}25$ mm (1") hole, at a 2mm offset to the centre of the push button location. Refer to the push button drilling diagram below.
- Using the supplied push button gasket [A2] as a template, drill 3 x $\text{Ø}3$ mm (1/8") mounting holes.
- Ensure the clear breather tube is inserted into the back of the push button.
- Fit gasket [A2] and push button [A1] in place (with hinged cover opening upwards, if mounted on vertical surface).
- Apply a small amount of sealing compound to the mounting holes.
- Fasten push button with provided 3 pcs. #6 x 19 mm screws [A9].

DRILLING TEMPLATE

PUSH BUTTON

NOT TO SCALE

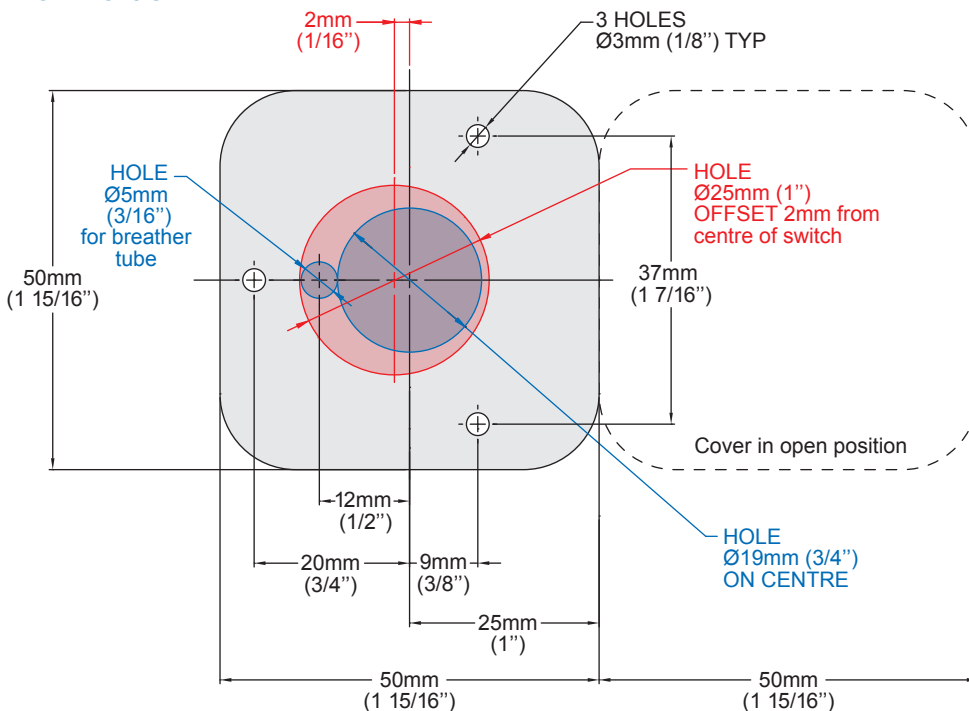

INSTALLATION INSTRUCTIONS

STEP 5

- Connect wires from push button to wires from motor unit as per electrical connection diagram p10 Detail A.

STEP 6

- Measure the total wire run distance from the battery to the motor unit and back to the battery.
- Refer to table below to determine the required motor unit to battery wire size (cross-section area), circuit breaker/fuse size and total battery capacity (Ah).
- Connect the motor unit to the battery bank, with the appropriate circuit breaker or fuse in the positive power wire line. The circuit breaker or fuse should be positioned as close to the battery as possible, in an accessible location so the switch can be turned off when not in use.

***Note:** The fuse should be a "slow blow" or "long delay" type to allow for start-up current spike.
WARNING: Do not use smaller wire than recommended in the table. This can cause malfunction of the winch and in worst case - FIRE. The wires should always be as short as possible.

WINCH	WIRE LENGTH*	12V. DC				24V. DC			
		WIRE SIZE	CIRCUIT BREAKER	ADDITIONAL BATTERY CAPACITY PER WINCH	MIN. TOTAL BATTERY BANK CAPACITY	WIRE SIZE	CIRCUIT BREAKER	ADDITIONAL BATTERY CAPACITY PER WINCH	MIN. TOTAL BATTERY BANK CAPACITY
46 ST E1	0-3 m / 0-10 ft	35 mm ²	150 A	123 Ah	300 Ah	25mm ²	70 A	57 Ah	150 Ah
	3-8 m / 10-27 ft	50 mm ²	150 A	123 Ah	300 Ah	35mm ²	70 A	57 Ah	150 Ah
50 ST E1	0-3 m / 0-10 ft	35 mm ²	150 A	123 Ah	300 Ah	25mm ²	70 A	60 Ah	150 Ah
	3-8 m / 10-27 ft	50 mm ²	150 A	123 Ah	300 Ah	35mm ²	70 A	60 Ah	150 Ah

* Wire length = Total cable length from battery to motor and back.

ELECTRICAL CONNECTION DIAGRAM

46/50 ST E1 SINGLE SPEED 12V/24V

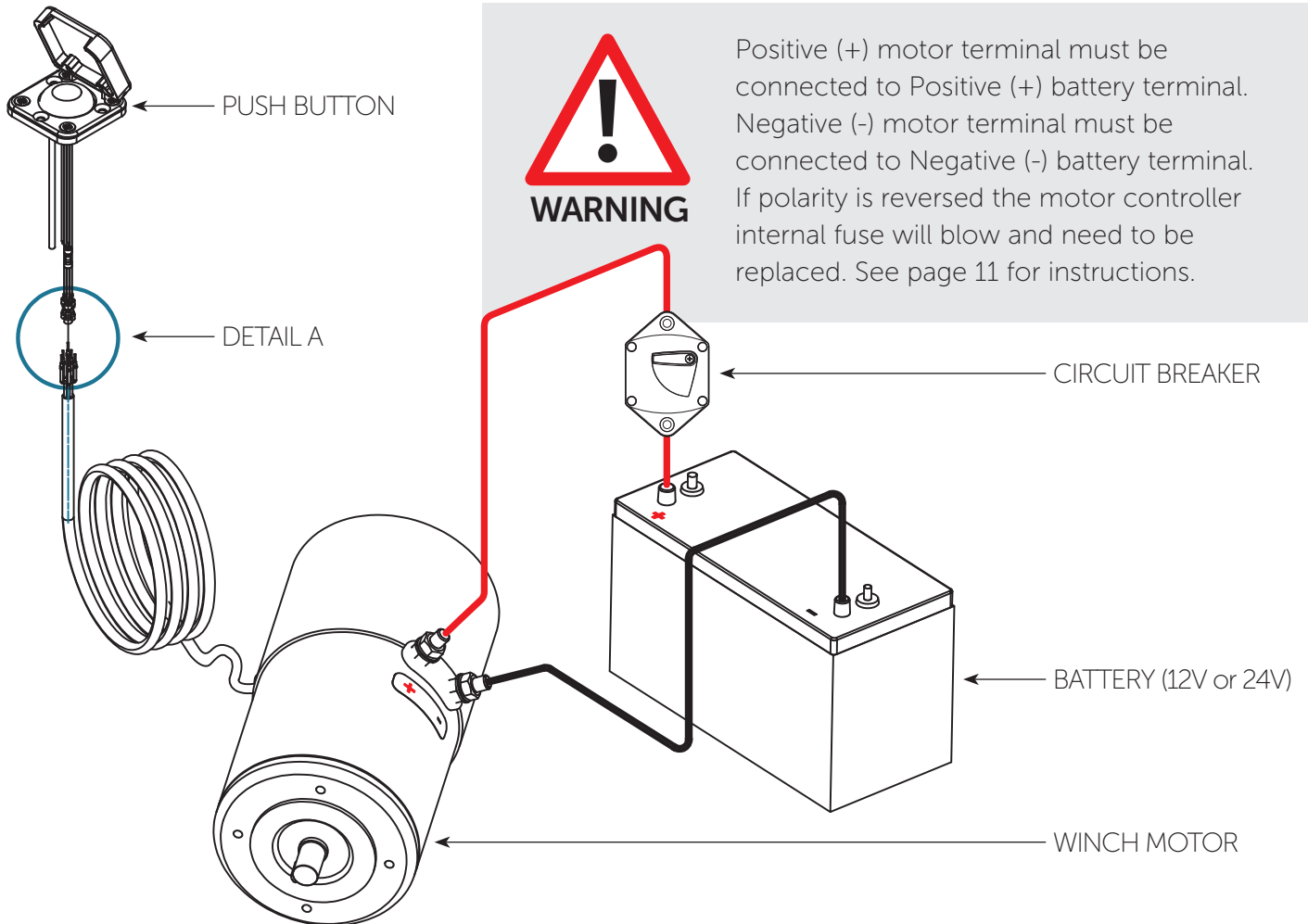

Positive (+) motor terminal must be connected to Positive (+) battery terminal. Negative (-) motor terminal must be connected to Negative (-) battery terminal. If polarity is reversed the motor controller internal fuse will blow and need to be replaced. See page 11 for instructions.

DETAIL A

STANDARD CONNECTION

PUSH BUTTON CABLE	MOTOR CABLE
1. Blue	= 1. Brown
3. Blue Black	= 3. Green
4. Red	= 4. Yellow

Wires are marked with numbered sleeves

Push button cable

- 1. Blue = Switch
- 3. Blue Black = Ground
- 4. Red = LED

Motor cable

- 1. Brown = Switch 1
- 2. White = Switch 2 (used for 2 speed motors only)
- 3. Green = Ground
- 4. Yellow = LED
- 5. Grey = Ratiometric current output
- 6. Pink = Low current cutout

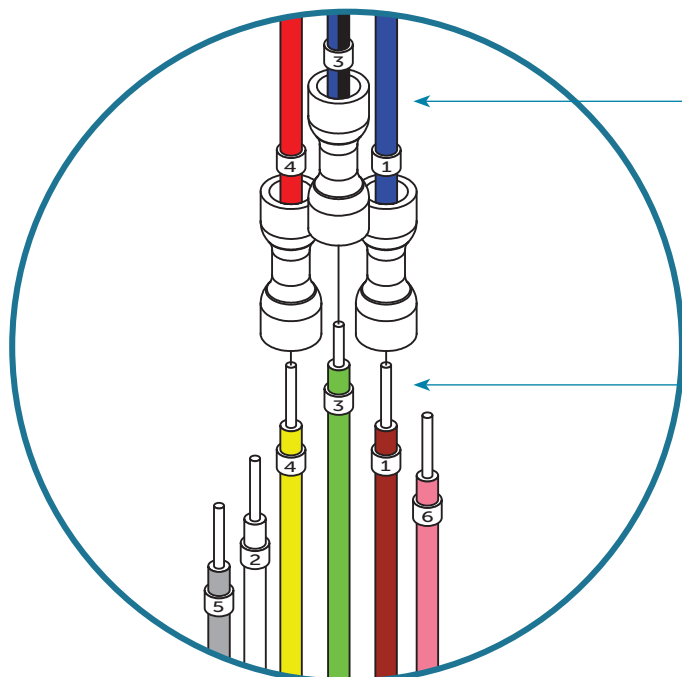

I TROUBLESHOOTING

E1 IN-BUILT SYSTEM PROTECTION

The E1 Electric Motor Unit has a very high level of in-built system protection, via monitoring of various operating parameters, its integrated controller and other protection/control componentry.

This functionality includes:

- Reverse polarity protection
- Mechanical overload protection
- System low voltage detection
- Thermal overload protection
- Continuous run time limiting
- Accidental start protection

REVERSE POLARITY PROTECTION

If the motor unit is inadvertently connected to the power system with reversed polarity the motor's internal fuse will blow. The fuse will have to be replaced before the motor will start again.

To replace the fuse:

- Remove the cable ties that secure the control cable to the outside of motor cover.
- Remove the two screws from the end of the outer motor cover (using a #1 Phillips head screw driver) - refer to picture below.
- Rotate the outer motor cover slightly and carefully pull the motor cover away from the motor unit. Note: After the first 5mm (3/16") the O-ring will release the cover, there will be no resistance the rest of the way, and very little force should be used so as not to damage the internal wiring connections.
- When the outer cover is clear of the internal components, set it to one side so that there is no tension on the internal control cable wires.
- Replace the 5A glass fuse, located on the PCB as shown below.
- Reassemble in reverse order. Make sure that the internal cables are not wedged between the cover and internal components and again that no force should be required to replace the cover until the O-ring is reached. Before pushing the cover on the final few millimetres over the O-ring, make sure that the screw holes in the outer cover are aligned with the threaded rods inside. Refer to picture below for threaded rod position.



Motor outer cover attachment screws

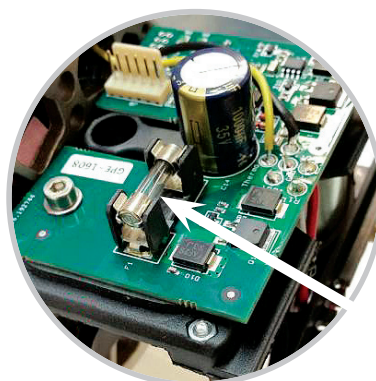

5A Glass Fuse PCB location



Threaded rods for motor outer cover attachment screws

I TROUBLESHOOTING

STATUS CODES

The E1 "Intelligent" Illuminated Push Button acts with the controller to flash status codes to assist in trouble shooting in the event of overload or where other system protection intervention occurs. The push button will flash a number of times in quick succession, followed by a short break, and then repeat again.

The number of flashes indicates the system status as follows:

- **1 Flash** **Maximum working load has been reached.**

The motor has cut out after reaching the pre-set maximum load for electrical operation of the winch. Status will automatically reset to normal and the winch will be ready for use 5 seconds after the button has been released, if the load has decreased below the max limit, and the button is pressed again.

- **2 Flashes** **Low system voltage detected.**

This will occur if the system voltage goes below 10.5 Volts (for 12V systems) and 21 Volts (for 24V systems) in idle state, or below 7.0 Volts (for 12V systems) and 18 Volts (for 24V systems) while running. Batteries should be recharged before the winch is used again. Status will automatically reset to normal and the winch will be ready for use when the voltage comes back above 11.0 Volts (for 12V systems) and 22 Volts (for 24V systems).

- **3 Flashes** **Max temperature of the motor has been reached.**

The motor has overheated. Status will automatically reset to normal and the winch will be ready for use when the motor has cooled down sufficiently (this may take some time). Ensuring adequate ventilation around the motor will help to avoid overheating.

- **4 Flashes** **Max temperature of the control board has been reached.**

The temperature of the control board has exceeded 85°C. Status will automatically reset to normal when the control board temperature drops below 75°C. Ensuring adequate ventilation around the motor will help to avoid overheating.

- **5 Flashes** **Push button error.**

Operation of the winch is prevented because a push button has been pressed when system power up is initiated – i.e. when power is supplied to the winch by closing the CB or battery switch. To reset status to normal, release the push button. If the error continues, check button wiring for fault.

- **6 Flashes** **Maximum continuous motor run time has been reached.**

The motor has been running continuously for approximately 10 minutes. To reset status to normal, release the push button, then press it again to resume operation.

- **7 Flashes** **Max relay cycles reached.**

The motor relay has been activated 20,000 times and will need to be replaced to ensure continued safe operation. Contact Ronstan or your local Andersen Winches distributor for advice.

I SERVICE & MAINTENANCE

***Note:** Always shut off power to the winch before commencing any service or maintenance task!

- The winch on top of the electric motor unit should be serviced as per the instructions in the relevant Winch Product Manual.
- The electric motor is a sealed unit and does not require regular servicing of internal parts.
- To avoid potential sea water ingress and to maximise the service life of your electric winch motor unit, it is recommended to re-lubricate the motor unit drive shaft Sealing Ring [7] once a year. Under intensive use, such as racing, charter or blue water sailing, we recommend lubrication twice a year.

To access the Sealing Ring [7], it is necessary to remove the winch from the winch base. Refer to the Winch Product manual for instructions.

The Sealing Ring should be lubricated with a grease such as Klüber ISOFLEX TOPAS NB 52, or Andersen Winch Grease.

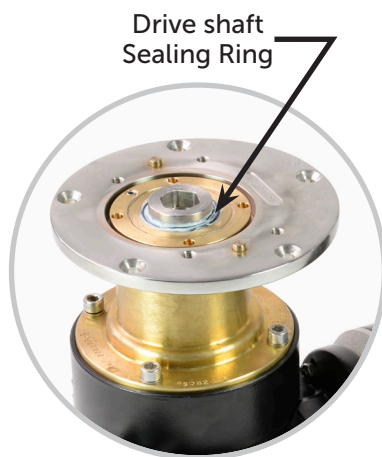

INSTALLATION DIMENSIONS

SIZE 46/50

NOT TO SCALE

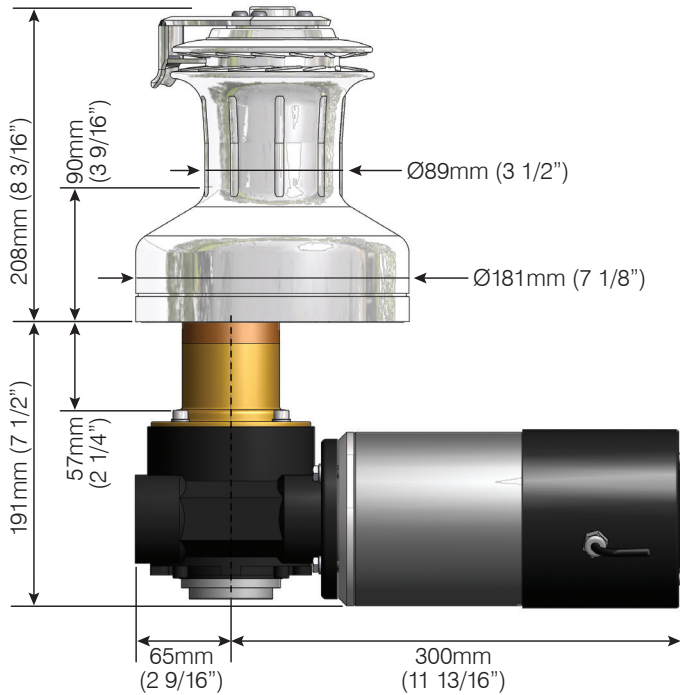

*Extensions are available to suit thicker deck thicknesses.
See website SUPPORT section for details.

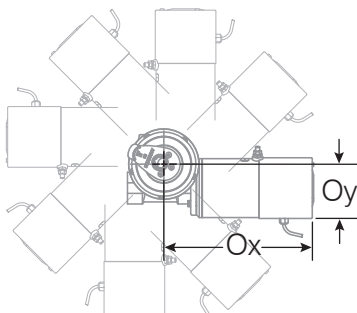
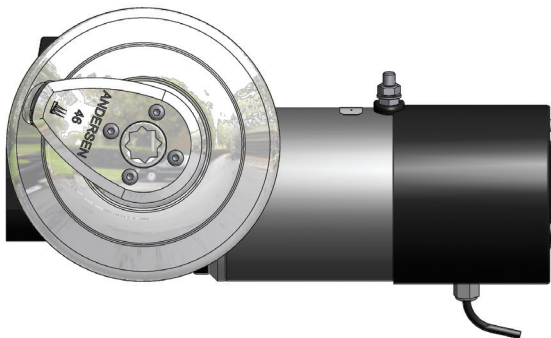
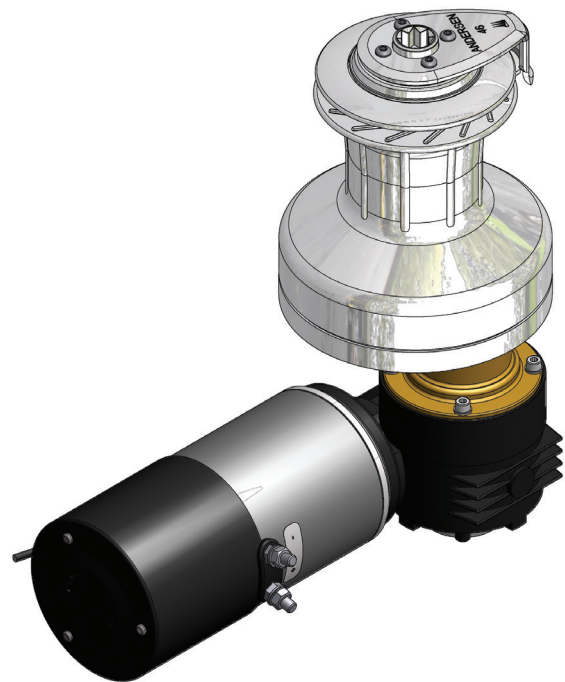

MOTOR OFFSET

Minimum Ox.....266mm (10 1/2")[^]
Oy.....144mm (5 11/16")[^]
Minimum Oy.....117mm (4 5/8")[^]
Ox... 303mm (11 15/16")[^]

[^] Values with motor in optimum position to minimise Ox or Oy. Oy value includes allowance for push button cable and fitting on the motor housing. Motor can be rotated at 45° intervals which will change Ox and Oy values.

WEIGHTS

	46ST	50ST
Winch only	7.8 kg (17.2 lb)	7.8 kg (17.2 lb)
Winch & motor unit	21.0 kg (46.3 lb)	21.0 kg (46.3 lb)

I DRILLING TEMPLATE

SIZE 46/50

NOT TO SCALE

SELF-TAILING ARM CAN
BE REPOSITIONED IN
45 DEGREE INCREMENTS
AFTER INSTALLATION

Ø 180mm
[7 3/32"]
WINCH BASE

18.75mm
[47/64"]

7.00°

25.80mm
[1 1/64"]

Ø 8.50mm [11/32"]
x 5 EQUALLY SPACED
ON A 155mm [6 7/64"]
P.C.D.

Ø 70mm
[2 3/4"]
CUTOUT FOR
ELECTRIC MOTOR

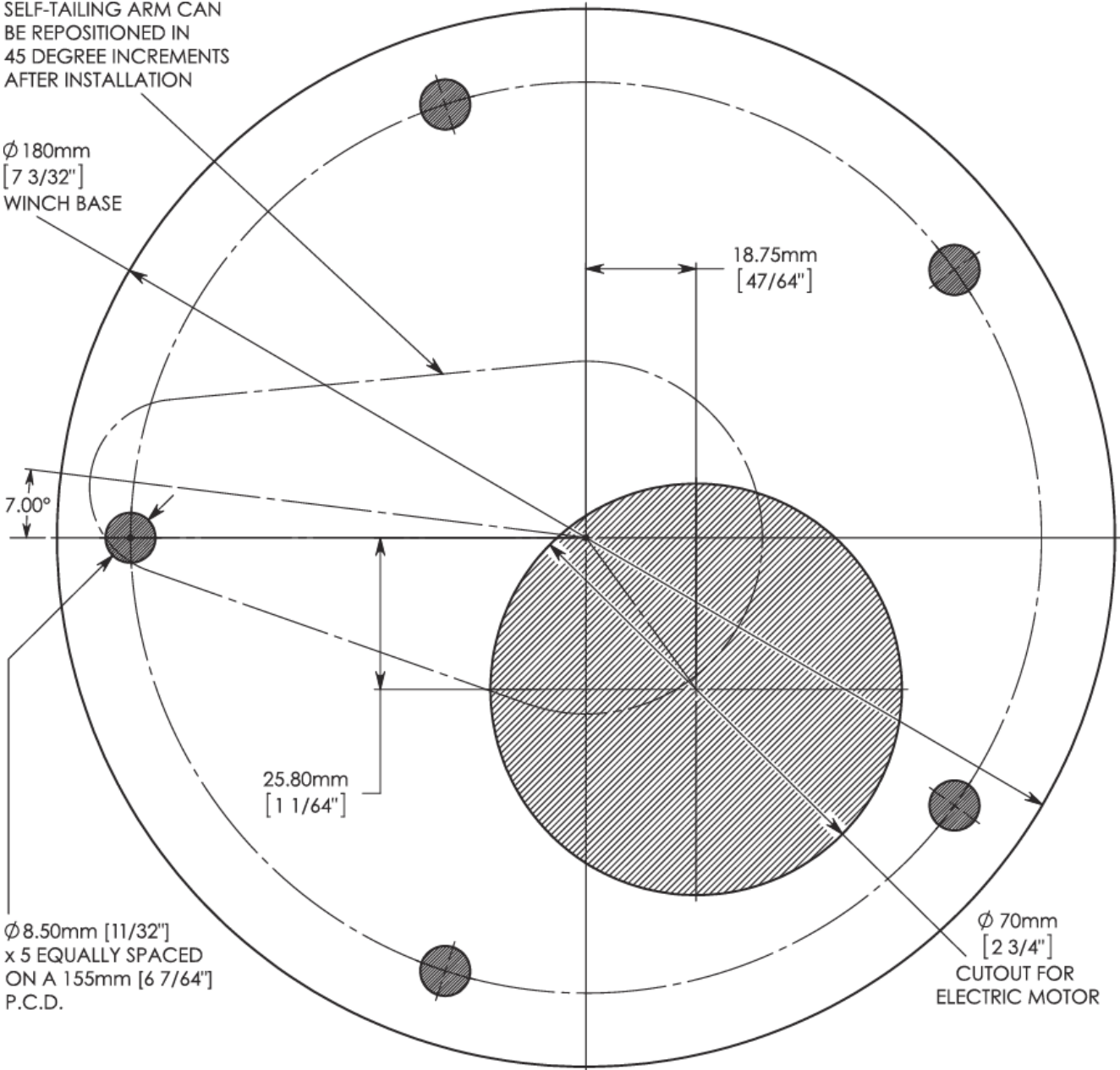

I SAFETY NOTICES

I ALL WINCHES



Read All Safety Notices and Product Manuals

Do not install or operate this winch before reading and fully understanding the contents of this Safety Notice Sheet and the Product Manual.



Stay Alert When Operating

Andersen winches are very powerful and have the potential to cause significant damage and/or serious injury if used improperly or without due caution and vigilance.



Operators Must be Trained

Help prevent significant damage and/or serious injury by ensuring any person operating a winch has a thorough understanding of its proper operation and is aware of the potential hazards involved. As a minimum, all winch operators must read and understand this Safety Notice Sheet and the Product Manual.

Particular attention is drawn to the following points:

- Children and others not qualified to operate an electric winch must be kept at a safe distance from the winch and any rigging or fittings that are under load.
- Long hair and/or loose clothing must be tied back to avoid being caught in the winch.
- In the event of a rope override or other fault, stop the winch and turn off power before attempting to resolve the problem.



Avoid Accidental Operation

Remove winch handles and turn off power to the winch when not in use to help avoid unsupervised or unintentional operation. Failure to do so could result in significant damage and/or serious injury.



Maintenance

Turn off power to the winch before performing any maintenance or service tasks. Failure to do so could result in significant damage and/or serious injury.



Lifting Operations

The winch must not be operated with the rope in the self tailer when used in any kind of lifting operation.

Any lifting operations should be conducted by two persons in order to maintain constant visual contact with the object being lifted.

Furthermore the self tailer must not be used as a cleat for a rope used to lift or suspend any object. The rope must be secured properly by tying off, or leading to a suitable fitting such as a cleat or bollard.

I Failure to observe these precautions could result in serious injury or death.

I DO NOT DISCARD



PRODUCT MANUAL

E1 Single Speed Electric Motor Unit, 12V & 24V
To Suit Self-Tailing Winch Sizes 46, 50

p18

| WORLDWIDE DISTRIBUTION & SERVICE

| Visit www.andersenwinches.com

| WARRANTY

| Visit www.andersenwinches.com

