

ANDERSEN

STAINLESS STEEL WINCHES

PRODUCT MANUAL

Compact Motor™ Above Deck Electric Winch 68/72ST

FOR USE WITH:

Compact Motor™ Electric Winches

RA2068015100 RA2072015100
RA2068015200 RA2072015200

Compact Motor™ Conversion Kits

RA2068215100 RA2072215100
RA2068215200 RA2072215200

Winch Versions:

68ST (≥V.1.0) 72ST (≥V.1.0)

Your Winch Version No. _____

Your Motor Serial No. _____



Contents

PAGE	
2	Functionality
3	Safety notices
4	Exploded view of assembly and items included
5	Parts list
6-10	Installation instructions - motor and push button
11	Important notes - electrical installation
12	Wiring diagram
13-16	Electrical installation
17	Winch installation
18-19	Troubleshooting
20	LED status codes / diagnostics
21	Service and maintenance
22	Contact and warranty information

ANDERSEN Stainless Steel Winches®

Your Andersen winch is made with the care and craftsmanship that come from more than sixty years of experience. Andersen winches are built to last, to retain their exceptional finish and to deliver season after season of reliable performance and sailing pleasure to their owners through the years.

Compact Motor™ functionality

The Andersen Compact Motor™ is a brushless DC motor, carefully matched to a low profile planetary gearbox, which requires less space for installation and draws considerably less current than traditional motor/gearbox configurations. Simplified electrical installation requires no external control box.

The Compact Motor™ includes a dedicated circuit breaker with integral controller and two illuminated “intelligent” push buttons which regulate speed and power in the low and high speed ranges of operation, in proportion to the pressure applied.

Manual operation is possible at any time using a normal winch handle.

Monitoring and protection

The integrated controller will cause the motor to stop without tripping the circuit breaker if one of the following conditions is detected:

- Maximum pulling load exceeded. The motor will cut out if the pre-set maximum pulling load of the winch for electrical operation is exceeded. Operation can resume within a few seconds when the load returns below the limit.
- Overheating. The motor will cut out if the temperature of the motor circuit reaches 60°C (140°F). Operation can resume when the temperature returns to normal.
- Maximum continuous run time exceeded. The motor will cut out after running continuously for 4 minutes and 15 seconds. Operation can resume after releasing the push button to pause operation for at least 30 seconds.

In these cases, the illuminated push button will flash, indicating that the controller will reset automatically when operating conditions return to normal.

SAFETY NOTICES

Read All Safety Notices and Product Manuals

Do not install or operate this winch before reading and fully understanding the contents of this Safety Notice Sheet and the Product Manual.

Stay Alert When Operating

Andersen winches are very powerful and have the potential to cause significant damage and/or serious injury if used improperly or without due caution and vigilance.

Operators Must be Trained

Help prevent significant damage and/or serious injury by ensuring any person operating a winch has a thorough understanding of its proper operation and is aware of the potential hazards involved. As a minimum, all winch operators must read and understand this Safety Notice Sheet and the Product Manual.

Particular attention is drawn to the following points:

- Children and others not qualified to operate an electric winch must be kept at a safe distance from the winch and any rigging or fittings that are under load.
- Long hair and/or loose clothing must be tied back to avoid being caught in the winch.
- In the event of a rope override or other fault, stop the winch and turn off power before attempting to resolve the problem.

Avoid Accidental Operation

Always turn off power to the winch at the circuit breaker and remove winch handles when not in use to help avoid unsupervised or unintentional operation. Failure to do so could result in significant damage and/or serious injury.

Maintenance

Turn off power to the winch before performing any maintenance or service tasks. Failure to do so could result in significant damage and/or serious injury.

Lifting Operations

The winch must not be operated with the rope in the self tailer when used in any kind of lifting operation. Any lifting operations should be conducted by two persons in order to maintain constant visual contact with the object being lifted. Furthermore the self tailer must not be used as a cleat for a rope used to lift or suspend any object. The rope must be secured properly by tying off, or leading to a suitable fitting such as a cleat or bollard.

Failure to observe these precautions could result in serious injury or death.

DO NOT DISCARD

Exploded View

68/72ST Above Deck Compact Motor™ 12V/24V

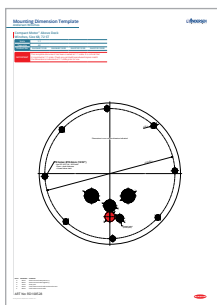
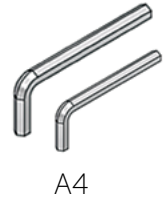
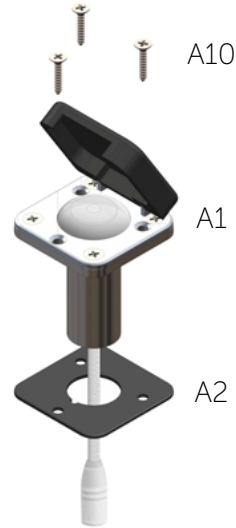
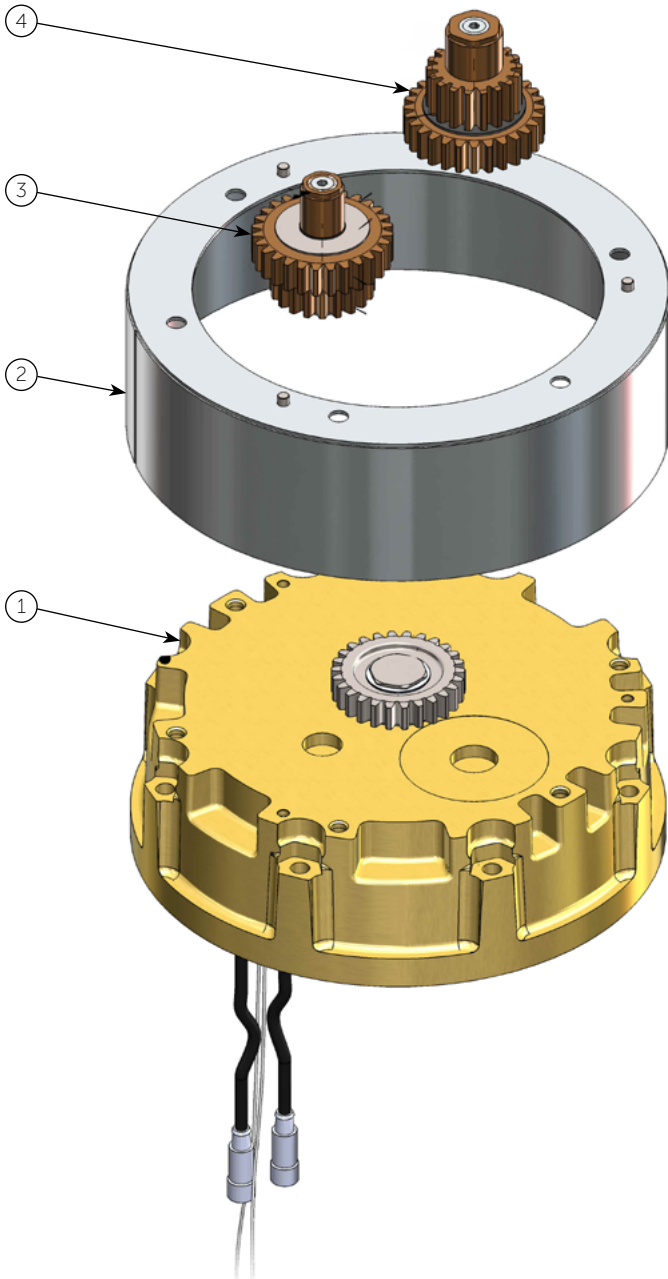

A3

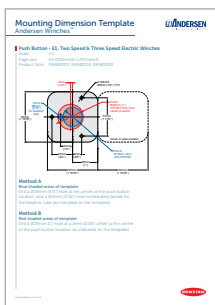

A3



A9



A15



A11

Parts List

ITEM NO.	QTY	DESCRIPTION	PART NO.
1	1	Motor Compact AD, 12V for 68-72ST	RD827500
1	1	Motor Compact AD, 24V for 68-72ST	RD827550
2	1	Base Cover, Stainless Steel	
3	1	Gear set, freewheel high gear	893400
4	1	Gear set, freewheel low gear	893300
A1	2	Push button with plastic cover	RA866000
A2	2	Push button gasket	735050
A3	1	Drilling template for 68-72ST Compact AD	
A3	1	Drilling template for RA866000 push button	
A4	1	Hex keys, metric	
A5	6	Screw SS, M10x20 hex socket CSK head	DIN7991-A4-M10X20
A9	1	Push button labels	RD100029
A10	6	Screw M4x20mm, self tapping	RD100025
A11	1	Product Manual	
A12	2	Control cable, 1000mm (39")	RD877610
A13	1	Circuit breaker with integral controller	877750
A14	1	Drain tube	RD877408
A15	1	Compact AD Seal Service Kit 68-72ST	RA710027
A16	1	Terminal extension set, red & black	877800

OPTIONAL ACCESSORIES:	
Push button, stainless steel cover	RA866010
Push button, stainless steel cover with hole	RA866020
Control cable extension, 1000mm (39")	RD877610
Control cable extension, 4000mm (157")	RD877611

Required for installation

- Hex keys, metric (included)
- Cross head screwdrivers
- Drill bit Ø10.5mm for M10 mounting bolts (or drill bit 13/32" for 3/8" bolts)
- Drill bit Ø3mm (1/8")
- Hole saws Ø16mm, Ø20, Ø25mm and Ø30mm (5/8", 13/16", 1" and 1 3/16")
- 8x ISO 4017-A4 M10 (3/8") mounting bolts; (L = 15mm (5/8") + deck thickness + thread below deck)
- 8x M10 (3/8") locking nuts and large washers (or backing plate to match drilling template)
- Spanners: 13mm for motor and circuit breaker terminals, 17mm (9/16") for winch mounting nuts
- Sealant / bedding compound
- Wire crimping tool/pliers
- Marine grade electrical power cables with lugs to suit your battery terminals and the M8 motor and circuit breaker terminals

Before Installation

Before installation, record the version number of your winch and the serial number of your motor in the space provided on the front cover of this manual for future reference. These details can be found as shown.



Winch production year and month [YY-MM] followed by version number are stamped on winch base between the mounting bolt holes.

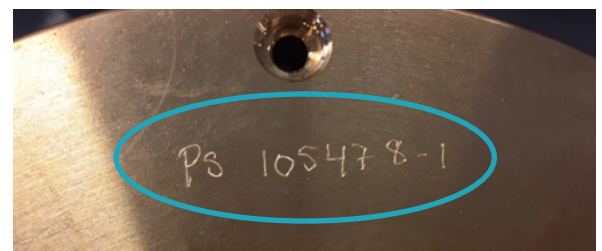

Serial number engraved on bottom of motor.

Installation Instructions

STEP 1

Determine the position of the winch and motor unit

- 1.1 Magnetic fields in the motor may affect compasses even when the motor is not in use. Install the motor at least 1m away from any compass, and always have your compass recalibrated after installation.
- 1.2 Mounting of an Above Deck Compact Motor on a vertical surface is not ideal as it increases exposure to potential problems of excessive moisture and water ingress. It is important to take care to protect the unit from unnecessary exposure, and carry out seasonal maintenance and regular lubrication of the motor shaft seal.
- 1.3 The winch should be positioned with the recommended line entry angle of 3-8° from horizontal. Refer to the winch product manual for details of correct line entry angle and self-tailing arm positioning.
- 1.4 Refer to the Winch Data Sheet for your winch model for clearance/space requirements for the wiring and drain tube below deck.
You may choose to drill a small pilot hole to indicate the position of the centre of the drive shaft, to assist with this.
- 1.5 Note the location of the drain port in the base of the motor. If the mounting surface is not horizontal due to deck camber or other factors, plan the installation such that the drain port is situated at the lowest point in relation to the slope of the mounting surface. The drain tube [A14] will be attached to this port to allow any moisture from condensation to escape and drain to the bilge. The position of the drain port is also indicated on the drilling template.
- 1.6 The self-tailing arm should be positioned to allow the rope to drop clear of the winch as it feeds out of the self-tailer. Positions will typically be as indicated by the shaded sectors in the diagram.

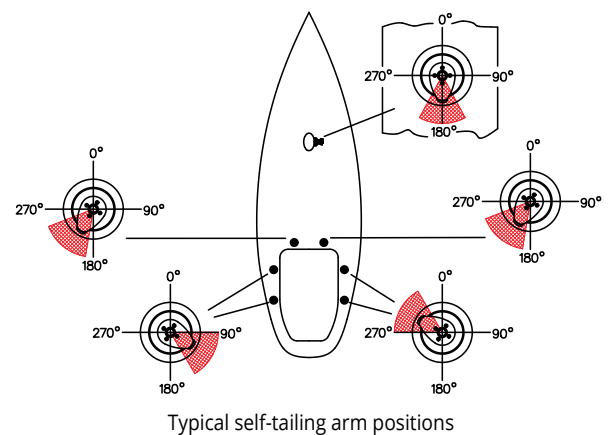
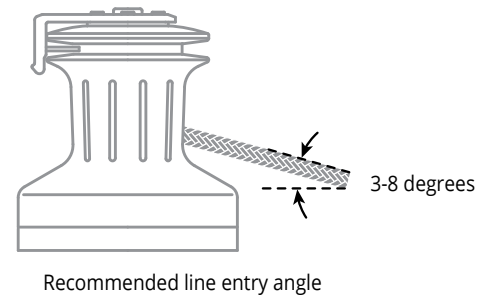

STEP 2

Prepare the mounting surface

- 2.1 After determining the mounting location and orientation, clean the mounting surface and use the drilling template [A3] as a guide. Ensure that the surface is flat and there is adequate space and clearance for operation of the winch.
- 2.2 With the drilling template in the desired orientation, drill the $\text{\O}10.5\text{mm}$ holes for the M10 mounting bolts (or $\text{\O}13/32''$ holes for $3/8''$ bolts).
- 2.3 Cut the required holes for the motor terminals, drain port and wiring as indicated on the drilling template
- 2.4 Clean any wood or fibreglass splinters from the holes, and clean the deck thoroughly to ensure deck sealant can adhere properly.



Drilling template use

STEP 3

Prepare and dry-fit the motor unit

- 3.1 Slide the stainless steel cover upward to remove it from the motor unit (refer to the exploded diagram at the beginning of this manual).
- 3.2 Fit the terminal extensions [A16] to the motor terminals, ensuring that the RED extension is fitted to the RED POSITIVE (+) motor terminal, and the BLACK extension is fitted to the BLACK NEGATIVE (-) motor terminal.
- 3.3 Remove the plastic plug from the drain port fitting and push the drain tube [A14] into the fitting until it stops. Lead the drain tube below deck to a low point in the boat where it can drain to the bilge, then cut off any excess length. At most there should only ever be a drop or two of water from condensation that will pass through the tube.
- 3.4 Place the motor in position on deck. The two wires for the thermal sensor can be passed through the 25mm hole together with one of the push button control cables. The other push button control cable is passed through the 20mm hole. Ensure that deck cut-outs and fastener holes align properly and there is adequate clearance for a good fit and assembly.

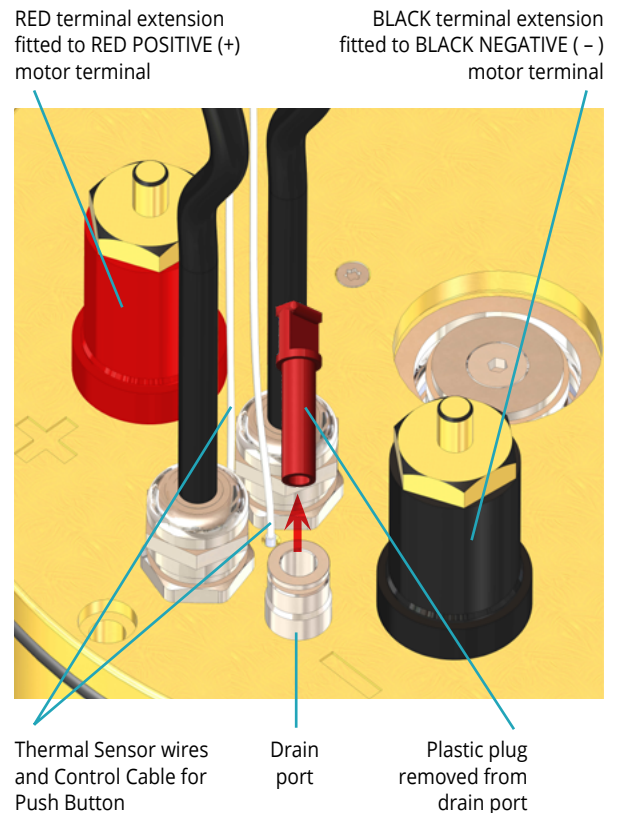

STEP 4

Install motor unit.

Having a second person to assist during this step may help to avoid fouling the wiring and drain tube with sealant as they are passed through the deck.

- 4.1 Apply sealant to the deck to prevent water ingress. In addition to sealing the mounting holes, apply a bead of sealant around the perimeter of the base to form a completely watertight seal.

NOTE: For mounting on metal surfaces, the base must also be completely isolated from the mounting surface to prevent galvanic corrosion.

- 4.2 Fit the motor unit [1] to the deck using the appropriate length ISO 4017-A4 M10 or 3/8" bolts, large washers or backing plate, and locking nuts.
- 4.3 Place the stainless steel cover [2] back on the motor unit and slide it down into position.

STEP 5

Install push buttons

The push buttons [A1] require 50mm clearance depth below the mounting surface. They are supplied with a short 190mm (7 1/2") cable lead; each is connected below deck to a 1000mm (39") long control cable [A12] and then to one of the short cable leads from the motor. Extension cables are available and may be ordered separately if necessary.

- 5.1 Select the desired location. For safety reasons it is recommended that the push buttons [A1] are located in close proximity to the winch, preferably within reach.
- 5.2 Determine the preferred orientation of the hinged covers (on vertical surfaces it should open upwards). Then using the drilling template or the rubber gasket [A2] as a guide, drill a Ø25mm (1") hole.
- 5.3 Drill a 3mm (1/8") hole in each of the mounting screw locations.
- 5.4 Fit gaskets and push buttons in place. Secure the push button units with the M4x20mm self tapping screws [A10], using a small amount of sealant at each hole.
- 5.5 Ensure that the breather channel on the side of the through-deck tube of the push button is clear and free of dirt or sealant.

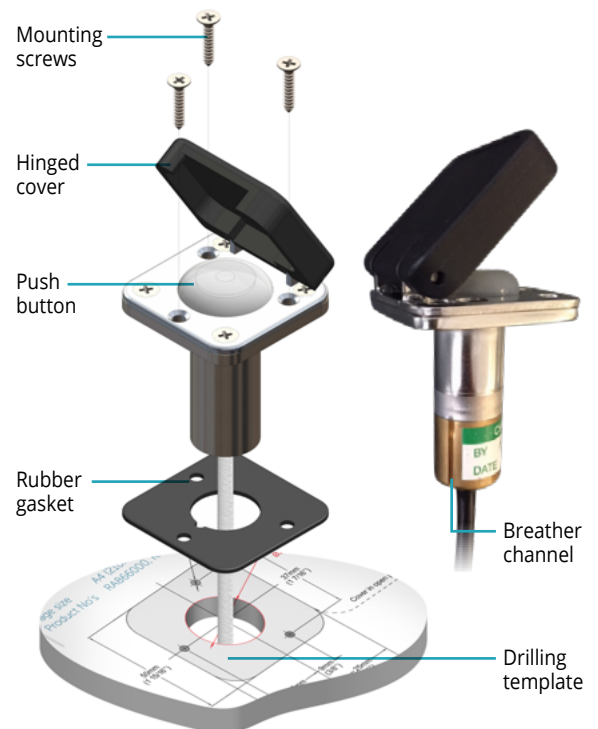

Push button installation

Important Notes - Electrical Installation



Incorrect electrical installation will result in permanent damage to the motor and invalidation of the warranty.

Warning!

The positive cable (+RED) must be connected to the positive (+RED) terminal of the motor. Incorrect polarity will cause permanent damage to the motor.

Battery compatibility

Andersen Compact Motors™ produced from 2011 onward are compatible with wet cell, AGM and gel batteries. Furthermore they may be used with Lithium-ion batteries supplied by Super B™, MasterVolt® and Victron®. These batteries have been tested for compatibility and have built-in protection to prevent damage to the motor, battery and other elements of the system. Other brands of Lithium-ion batteries are NOT approved for use with Andersen Compact Motors™.

Super B™ is a trademark of Super B International B.V.

MasterVolt® is a registered trademark of MasterVolt International B.V.

Victron® is a registered trademark of Victron Energy B.V.

Operation

The Andersen Compact Motor™ electric winch uses a brushless DC motor. Brushless DC motors draw current from the battery when operating, and can send current back to the battery when spinning down unloaded. Avoid operating the winch using the motor at high speed with no load on the drum, as spinning down an unloaded motor from high speed can stress the motor and battery and could result in reduced service life or damage to the motor, battery or other elements of the system.

Further Considerations

- Always disconnect power when not in use, and before performing any service or maintenance work on an electric winch.
- Use only an original Andersen control cable to connect the push buttons to the Compact Motor™. Extension cables may be ordered separately.
- Use only the Andersen circuit breaker supplied with your Compact Motor™; do not use it with other devices.
- Supply power to the motor only from the battery; never from an external power supply.
- Refer to the wiring diagram and cable size recommendations in the Andersen Winch Data Sheet for the model and voltage corresponding to your Andersen Compact Motor™ Electric Winch.
- Never use solvents for cleaning control cables or wires – use only alcohol for this purpose.

Failure to observe these notices will invalidate the warranty.

Wiring Diagram



WARNING

The positive cable (+RED) must be connected to positive terminal of the motor.

INCORRECT POLARITY WILL CAUSE PERMANENT DAMAGE TO THE MOTOR AND INVALIDATE THE WARRANTY!

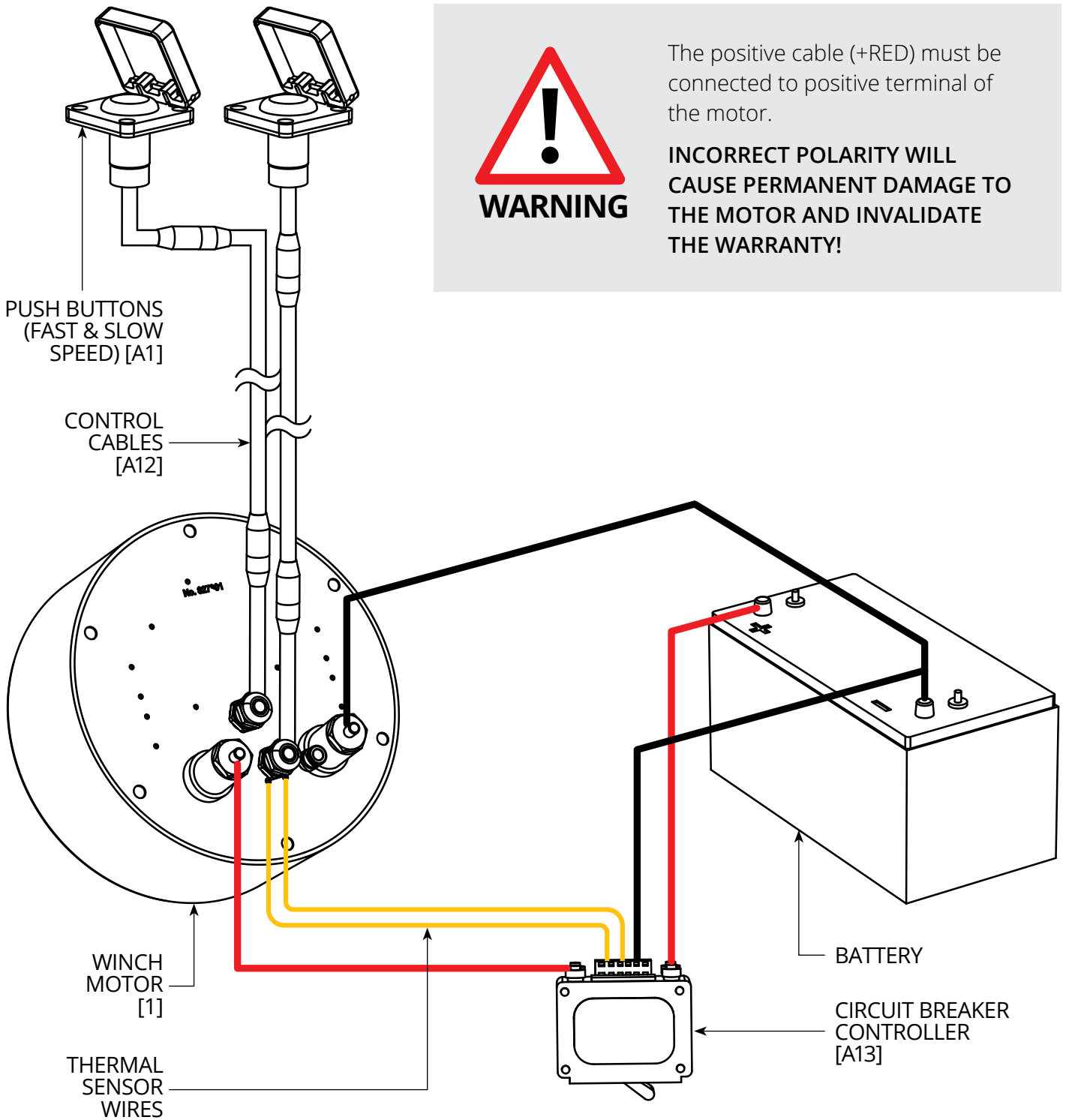

Motor Detail

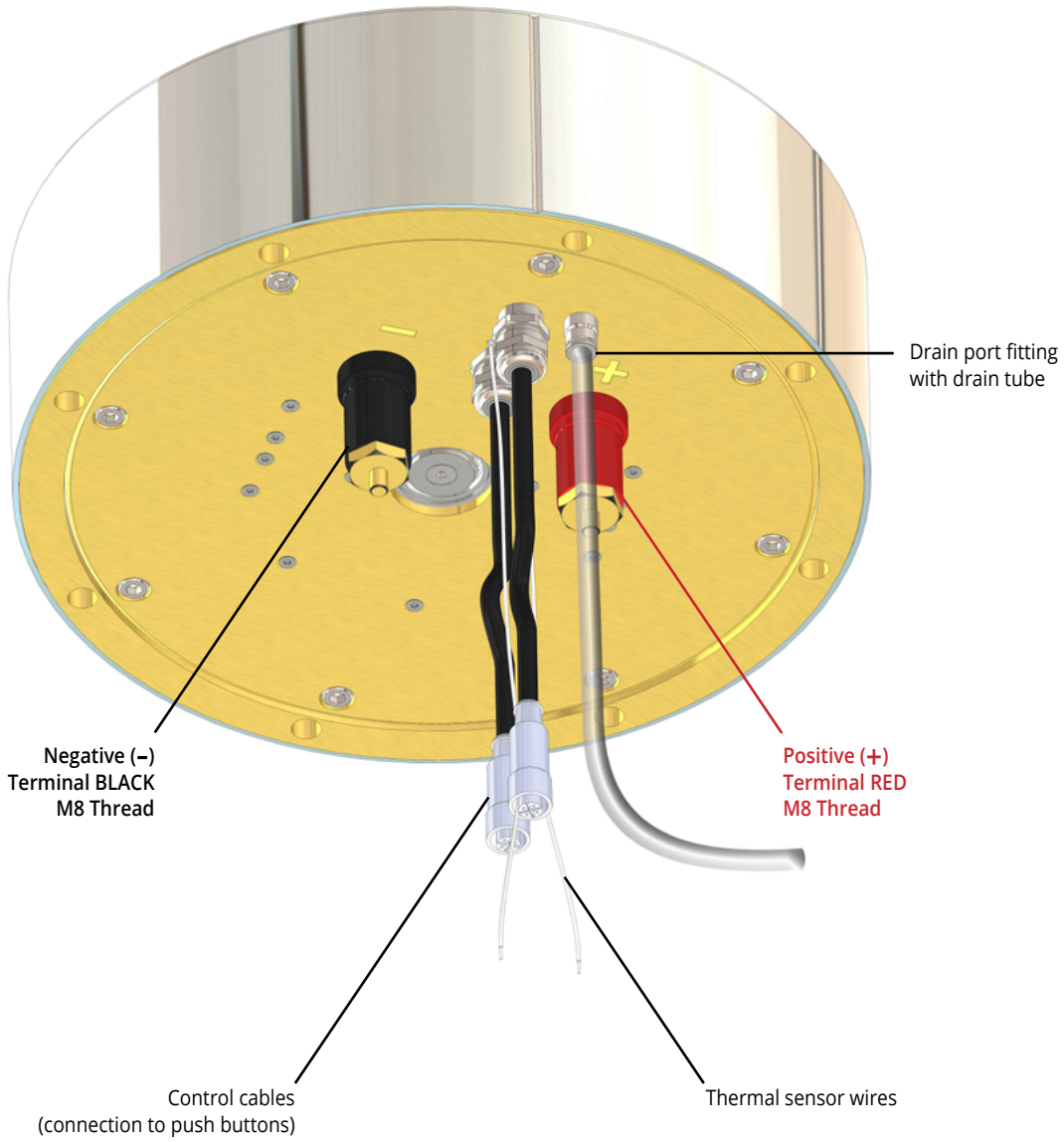

STEP 6

Prepare the power cables

- 6.1 Choose the shortest and most direct route possible for the cables, in order to minimise voltage drop between the battery and the motor.
- 6.2 Measure the distance from the battery to the motor, and back again via the circuit breaker, to determine the necessary total cable length.
- 6.3 Consult the table in the Winch Data Sheet for the model and voltage corresponding to your Andersen Compact Motor™ Electric Winch, to determine the minimum wire size for your cables according to the total cable length required for your installation. If in doubt, consider choosing a thicker cable as this will help to minimise voltage drop.
- 6.4 Make up the cables with lugs to suit the terminals of your battery and the M8 terminals of the motor and circuit breaker. The circuit breaker can accept cable lug size for max. wire size 50mm².

STEP 7

Install the circuit breaker



Ensure that the circuit breaker is switched to the "OFF" position before making any wiring connections.

- 7.1 Choose a suitable location for the circuit breaker [A13] in an easily accessible position as close as possible to the battery.
- 7.2 Connect the two thermal sensor wires from the motor to the terminals marked "TER. SW" on the back of the circuit breaker.
- 7.3 Use a 0.75mm² wire to connect the terminal marked "MINUS" on the back of the circuit breaker to the NEGATIVE (-) terminal of the battery.

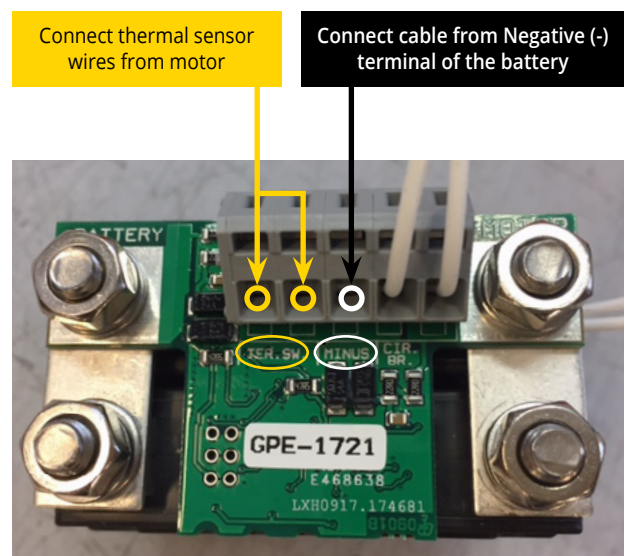

Circuit breaker wiring connections

STEP 8

Connect power and push button cables

8.1 NEGATIVE (-) BLACK connection from motor to battery:
Connect the NEGATIVE (-) BLACK terminal of the motor to the NEGATIVE (-) BLACK terminal of the battery using the (-) BLACK power cable prepared in Step 6. Tighten the nut on the motor terminal to a maximum torque of 12Nm (9 ft lb).

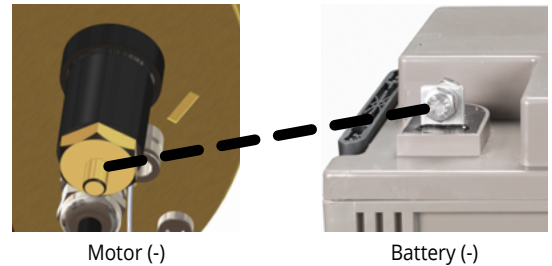

8.2 POSITIVE (+) RED connection from motor to circuit breaker:
Connect the POSITIVE (+) RED terminal of the motor to the terminal marked "+ MOTOR" on the circuit breaker using the (+) RED power cable prepared in Step 6. Tighten the nut on the motor terminal to a maximum of 12Nm (9 ft lb). Ensure that the cable lug is not touching the printed circuit board, and tighten the nut on the circuit breaker terminal to a maximum torque of 5Nm (4 ft lb).

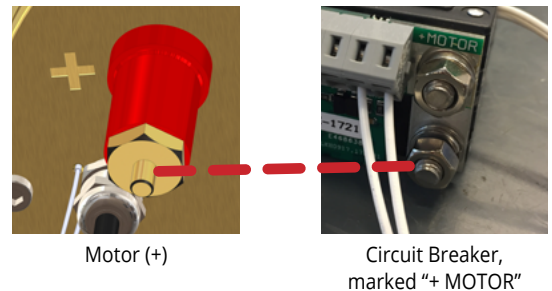

8.3 POSITIVE (+) RED connection from circuit breaker to battery:
With the circuit breaker switched to the "OFF" position, connect the terminal on the circuit breaker marked "+ BATTERY" to the POSITIVE (+) RED terminal of the battery using the (+) RED power cable prepared in Step 6. Ensure that the cable lug is not touching the printed circuit board, then tighten the nut on the circuit breaker terminal to a maximum torque of 5Nm (4 ft lb).

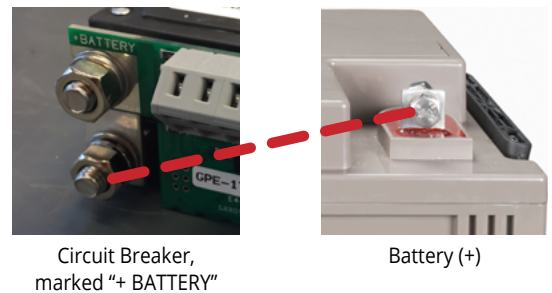

8.4 Connect the push button control cables [A12] to the short cable leads at the push buttons and the motor.

STEP 9

Check installation

9.1 The PCB at the rear of the circuit breaker is fitted with 3 LED indicators, located along its edge as indicated in the photo.

Yellow LED

The yellow LED may signal a status code by emitting a sequence of flashes once every 20 seconds. Count the number of flashes and refer to the Troubleshooting section of this manual.

Red LED

The red LED flashes when a fault has been detected. Refer to the Troubleshooting section of this manual.

Green LED

In normal operation the green LED illuminates continuously for the first 5 minutes after switching to "ON", and flashes once every 20 seconds thereafter. It will stop flashing a few seconds after switching the circuit breaker to "OFF".

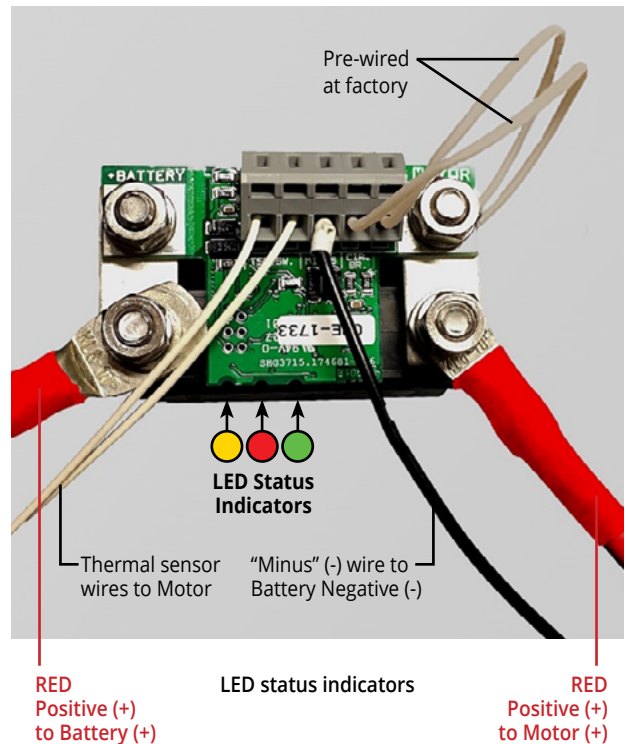

9.2 Switch the circuit breaker to "ON". The green LED on the PCB at the rear of the circuit breaker should illuminate. Switch the circuit breaker back to "OFF". The green LED should go off after a few seconds. If this is not the case, refer to the table below.

Fault	Possible Causes	Action
Green LED does not illuminate.	Circuit breaker is OFF, or there is a poor connection of MINUS wire from the circuit breaker to NEGATIVE (-) battery terminal.	Verify the connection of the MINUS wire, see step 7. Then check that the circuit breaker is ON.
Green LED remains illuminated continuously for more than a few seconds after switching circuit breaker to OFF.	Cables on the circuit breaker terminals labelled MOTOR and BATTERY have been inverted.	With the circuit breaker OFF, swap the cable connections to these terminals on the circuit breaker and then try again.
Red LED flashes 4 times, followed by Green and Yellow both flashing.	No MINUS wire connected, or incorrect/faulty connections to the PCB terminals.	Review details of steps 7 and 8, check all connections to the circuit breaker.

9.3 Verify that the push buttons are illuminated. If not, check connection of push button control cables.

9.4 With the circuit breaker switched to "ON", test the motor by pressing one of the push buttons. Bring the motor gradually up to half speed, and then gradually release pressure on the button until it slows to a stop. The motor and gearbox operation should be smooth and quiet.

STEP 10

Winch Installation

10.1 Use a hex key to remove the screws at the top of the winch, then lift off the self-tailing arm and the drum to expose the centre stem and gears. Position the centre stem of the winch on the motor unit with mounting holes aligned, Secure it to the motor unit using the M10 countersunk head screws [A5] provided, then fit the drum to complete the assembly.

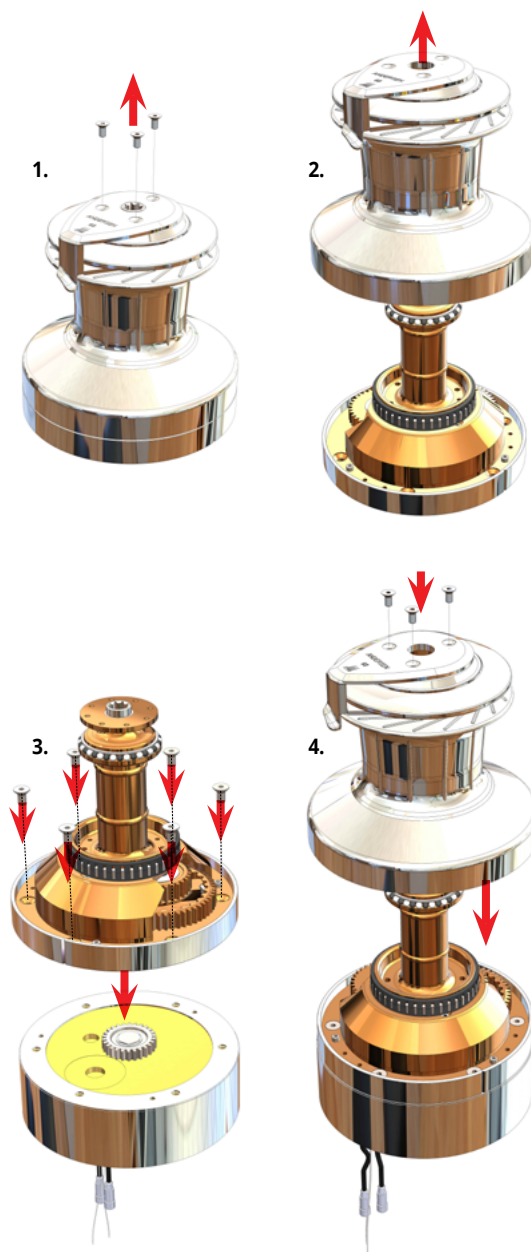

Winch installation

10.2 Test the winch by rotating the drum by hand and operating the winch manually with handle. The winch should operate smoothly in both gears. Then remove the handle and test electrical operation by pressing one of the push buttons.

Troubleshooting

Compact Motor™ electric winches have built-in monitoring and protection features to enhance safety and avoid permanent damage to the electronic and mechanical components of the motor and winch.

Automatic cut-out and reset

The integrated controller will cause the motor to stop without tripping the circuit breaker if one of the following conditions is detected:

- Maximum pulling load exceeded. The motor will cut out if the pre-set maximum pulling load of the winch for electrical operation is exceeded. Operation can resume within a few seconds when the load returns below the limit.
- Overheating. The motor will cut out if the temperature of the motor circuit reaches 60°C (140°F). Operation can resume when the temperature returns to normal, which may take some time.
- Maximum continuous run time exceeded. The motor will cut out after running continuously for 4 minutes and 15 seconds. Operation can resume after releasing the push button for a pause of at least 30 seconds.

In these cases, the illuminated push button will flash, indicating that the controller will reset automatically when operating conditions return to normal.

Fault detection and identification

If a fault occurs that requires investigation or intervention, the LED indicators on the circuit breaker can assist with troubleshooting and diagnostics. These indicators are located along the edge of the PCB, at the rear of the circuit breaker as shown in step 9 of this manual.

Troubleshooting Guide

FAULT	POSSIBLE CAUSE	ACTION
Excessive vibration or noise from motor/gearbox unit.	Mounting surface not flat.	Relax tension on motor unit mounting bolts and try running the motor. If this reduces noise/vibration, rectify mounting surface and reinstall motor unit.
Motor stops; push button LED flashes	The motor has cut out after reaching the pre-set maximum load for electrical operation of the winch.	Release the push button and run the winch with reduced load.
	Motor circuit overheated; temperature above 60°C (140°F).	When the motor has cooled down sufficiently (this may take some time), status will automatically reset to normal and the winch will be ready for use. Ensure adequate ventilation around the motor.
	Running time has exceeded +/- 4 minutes.	Release the push button and start again after 30 seconds.
	Damaged control cable (push button to motor).	Replace cable if necessary.
Motor will not start; push button LED not illuminated.	Circuit breaker and/or battery switch may be "OFF".	Check and switch to "ON".
	No power supply to motor.	Check power cables are properly connected to the battery and circuit breaker.
	Push button disconnected.	Check control cables for push button and motor are connected.
Motor will not start; push button LED is illuminated.	Incorrect or insufficient voltage in power supply to motor.	Restore normal voltage to power supply.
	Damaged control cable (push button to motor).	Replace cable if necessary.
Circuit breaker trips and switches to OFF after being reset.	Refer to LED Status Code table in this section of the manual.	Address fault identified in LED Status Code table and reset the circuit breaker.
	Incorrect or insufficient voltage in power supply to motor.	Charge or change battery.
		Check terminal connections.
		Restore normal voltage to power supply and reset the circuit breaker.
	Thermal sensor wires disconnected or damaged.	Re-connect thermal sensor wiring or replace if damaged.
Motor circuit severely overheated; temperature above 70°C (158°F) trips circuit breaker to OFF.	When the motor has cooled down sufficiently (this may take some time), status will automatically reset to normal and the winch will be ready for use. Ensure adequate ventilation around the motor. If problem persists or re-occurs contact your Andersen dealer.	
Circuit breaker trips and switches to OFF while operating the winch.	Refer to Status Code Table in this section of the manual.	Address fault identified in LED Status Code table and reset the circuit breaker.
Green LED on circuit breaker does not illuminate when circuit breaker switched to ON, or flashes every 20 seconds in normal use.	MINUS wire from circuit breaker to battery terminal is disconnected or damaged.	Check cable and terminal connections at circuit breaker and battery.
	PCB or its terminals may be damaged.	Contact your Andersen dealer, replace PCB if necessary.
Circuit breaker trips, switches to OFF and no status code flashes.	Current draw exceeds maximum rating of circuit breaker.	Check electrical installation and ensure connections to circuit breaker are correct.

LED Status Codes / Diagnostics

GREEN	In normal operation the green LED illuminates continuously for the first 5 minutes after switching the circuit breaker to ON, flashes once every 20 seconds thereafter and goes off a few seconds after switching the circuit breaker to OFF.
CONTINUOUS with circuit breaker ON	In normal operation the green LED illuminates continuously for the first 5 minutes after switching to the circuit breaker to ON, and flashes once every 20 seconds thereafter.
CONTINUOUS with circuit breaker OFF	Circuit breaker wired incorrectly; positive (+) cable connections to terminals labelled MOTOR and BATTERY have been inverted.
FLASHING	In normal operation, 5 minutes after switching the circuit breaker to ON the green LED will switch from continuous illumination to flashing once every 20 seconds.
NOT ILLUMINATED circuit breaker ON	Circuit breaker wired incorrectly; positive (+) cable connections to terminals labelled MOTOR and BATTERY have been inverted.
NOT ILLUMINATED circuit breaker OFF	In normal operation the green LED will go off a few seconds after switching the circuit breaker to OFF.

RED	The red LED will illuminate if a fault is detected. If a status code is available it will be indicated by the flashing yellow LED.
NOT ILLUMINATED	In normal operation the red LED will not be illuminated.
FLASHING 4 times, then yellow LED starts flashing	Check Yellow LED status codes below.
FLASHING yellow LED not flashing	The circuit breaker can not be tripped by signal from PCB. Thermal sensor wires disconnected, or incorrect connection of positive (+) cables between motor, circuit breaker and battery.
FLASHING 4 times, then green and yellow LED start flashing	MINUS wire from circuit breaker to negative (-) battery terminal not connected, or incorrect/faulty connections to the PCB terminals.

YELLOW	The yellow LED signals a status code by emitting a sequence of flashes once every 20 seconds.
3 flashes	High system voltage detected when power supply first connected. Exceeds pre-set limit for power up; check battery and any battery charging devices.
4 flashes	High current draw detected when power supply first connected. Exceeds pre-set limit for power up; may indicate motor failure or incorrect wiring.
5 flashes	Extremely low system voltage detected; check battery, charging devices and electrical installation.
6 flashes	Low system voltage detected; check battery, charging devices and electrical installation.
7 flashes	Continuous low current consumption (≥ 15 minutes), check electric installation.
8 flashes	Continuous low current consumption (≥ 8 minutes), check electric installation.
9 flashes	High system voltage detected during operation; check battery and any battery charging devices.
10 flashes	Constant high system voltage detected; check battery and any battery charging devices.
11 flashes	Status code not assigned.
12 flashes	Status code not assigned.
13 flashes	Motor overheated above 70°C (158 °F), or damaged thermal sensor wiring.
14 flashes	Circuit breaker wired incorrectly; positive (+) cable connections to terminals labelled MOTOR and BATTERY on the circuit breaker have been inverted.

Service and Maintenance

Proper care and maintenance of your Andersen products will ensure many years of reliable service. For your Compact Motor™ unit it is essential that the following service procedures are carried out at the recommended intervals.



Safety First! Always disconnect power before performing any service or maintenance work on an electric winch.

Periodic lubrication of the motor drive shaft lip seal:

Lubrication of the motor drive shaft lip seal is recommended once a year to condition the lip seal and avoid water ingress. To access the seal for lubrication, remove the winch, circlip and drive gear as shown.

Liberal apply a high quality bearing grease such as Klüber Isoflex® TOPAS NB52. Andersen Winch Grease may also be used for annual lubrication.

Isoflex® is a registered trademark of Klüber Lubrication München SE & Co. KG



Remove the circlip to lift the drive gear and expose the lip seal in the shaft recess.

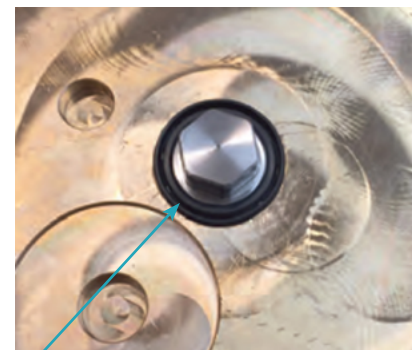

Lubrication of motor drive shaft lip seal.

Periodic replacement of the motor drive shaft lip seal

Replacement of the motor drive shaft lip seal is recommended every 3 to 5 years, depending on usage, in order to avoid water ingress and ensure a long and trouble-free service life. In practice every 5 years will be sufficient for most users, while the shorter interval is advisable for winches that see more constant usage or are installed in more exposed installations.

A service kit is provided with your new Compact Motor™ for the first lip seal replacement. It includes step-by-step instructions for the procedure and all necessary spare parts.

Planetary gearbox and drive shaft inspection & service

Inspection, cleaning and lubrication of the planetary gearbox is recommended at five year intervals. Combining this service procedure with the periodic replacement of the motor drive shaft lip seal will ensure that your Compact Motor™ is always performing at its best. Instructions for this service procedure can be downloaded from the Andersen website.

Winch inspection & service

Inspection and service of your Andersen winch is recommended at two year intervals. For information consult the separate product manual for your winch model which contains instructions, assembly diagrams and information about spare parts. Product manuals are available for download from the Andersen website.

Contact

Andersen Stainless Steel Winches® are manufactured by **Ronstan Denmark ApS**.

Jægervænget 36,

7100 Vejle

Denmark

info@andersenwinches.com

WORLDWIDE DISTRIBUTION & SERVICE

Visit www.andersenwinches.com

WARRANTY

Visit www.andersenwinches.com