

ANDERSEN

STAINLESS STEEL WINCHES

Service Kits for 46, 50, 52, 58, 62ST
"Above Deck" Compact Motor™

*Instructions for Lip Seal
Replacement and
Gearbox Service*



RA710025 Service Kit for 46 - 50ST "Above Deck" Compact Motor™
RA710026 Service Kit for 52, 58, 62ST "Above Deck" Compact Motor™

Instructions for Lip Seal Replacement and Gearbox Service

We recommend replacement of the drive shaft lip seal on your Compact Motor™ every 3 to 5 years, depending on usage, in order to avoid water ingress and ensure a long and trouble-free service life.



Safety First! Always disconnect power before performing any service or maintenance work on an electric winch.

Service Kit Contents

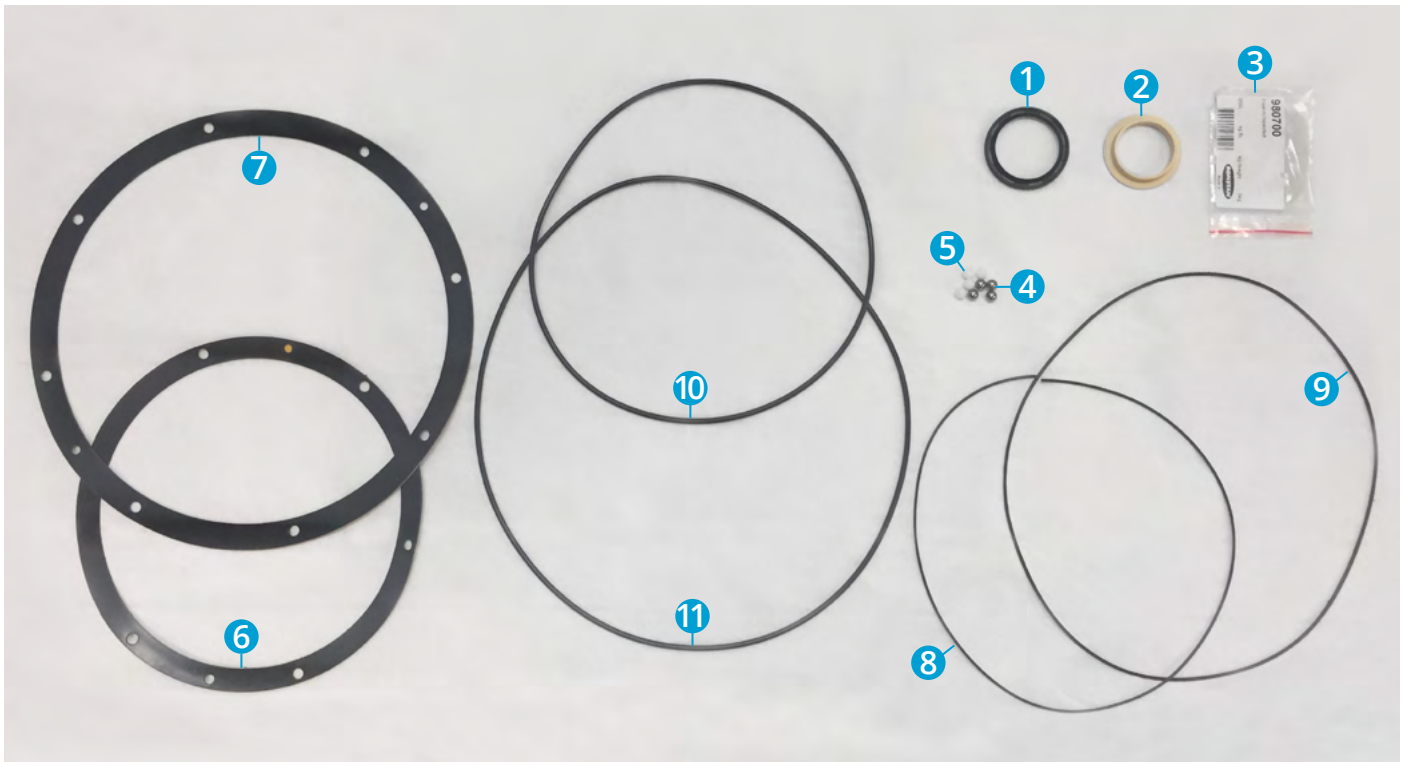

Please take a moment to familiarise yourself with the contents of your RA710025 or RA710026 service kit.

- | | |
|--|--|
| 1 RD100469 35mm x 45mm x 4mm Lip Seal | 7 822000 Gasket for <u>52-58-62ST ONLY</u> |
| 2 877200 Glide Bushing | 8 874100 NBR O-ring Ø 168 x 1,5 for <u>46-50ST ONLY</u> |
| 3 980700 Klüber Isoflex® TOPAS NB52 Grease | 9 RD877502 NBR O-ring Ø 205 x 1,5 for <u>52-58-62ST ONLY</u> |
| 4 724900 Stainless Steel ball bearings, 4 pcs. | 10 RD877504 NBR O-ring Ø 184,5 x 3 for <u>46-50ST ONLY</u> |
| 5 724902 Acetal ball bearings, 4 pcs. | 11 RD877505 NBR O-ring Ø 240 x 3 for <u>52-58-62ST ONLY</u> |
| 6 821900 Gasket for <u>46-50 ST ONLY</u> | |

Isoflex® is a registered trademark of Klüber Lubrication München SE & Co. KG

Optional Items: (recommended - may be ordered separately)



Part no. 821811
Pair of support blocks
(12mm x 40mm x 250mm)



Part no. 821810
Mounting tool for Lip Seal



Part no. RA500001-1
Andersen Winch Grease

Other items that you will need:

- Hex keys for M4 and M6 socket head screws
- Small flat screw driver
- Mallet or soft hammer
- Soft cloth or paper towels
- Andersen Winch Grease – Part no. RA500001-1 (may be ordered separately if you don't already have it on board)
- Threadlock, medium strength. To allow for the fasteners to still be removable for future servicing.
- Small brush for grease
- Mineral spirits (white spirits) for cleaning and degreasing. Do not use alcohol or other solvents for cleaning.

Getting Started

1. AFTER DISCONNECTING POWER, remove the winch drum to access the mounting screws and remove the winch from the motor/gearbox unit – if in doubt, see the service manual for your winch.
2. After removing the winch, slide the stainless steel cover up to remove it and expose the motor/gearbox unit.
3. Remove the 8x M6 mounting bolts that secure the motor/gearbox to the deck.
4. Disconnect all wiring connections.
5. Leaving in place the 2x M4 socket head screws that join the motor and gearbox, remove the motor/gearbox unit from the deck.

Note: If there is a strong adhesive or sealant bond between the motor and deck, it may be preferable not to remove the motor, especially if mounted on a teak deck. In this case, the motor may be left on the deck while carrying out this service procedure. Proceed anyway to the next steps and follow the instructions for disassembly of the gearbox from the motor.

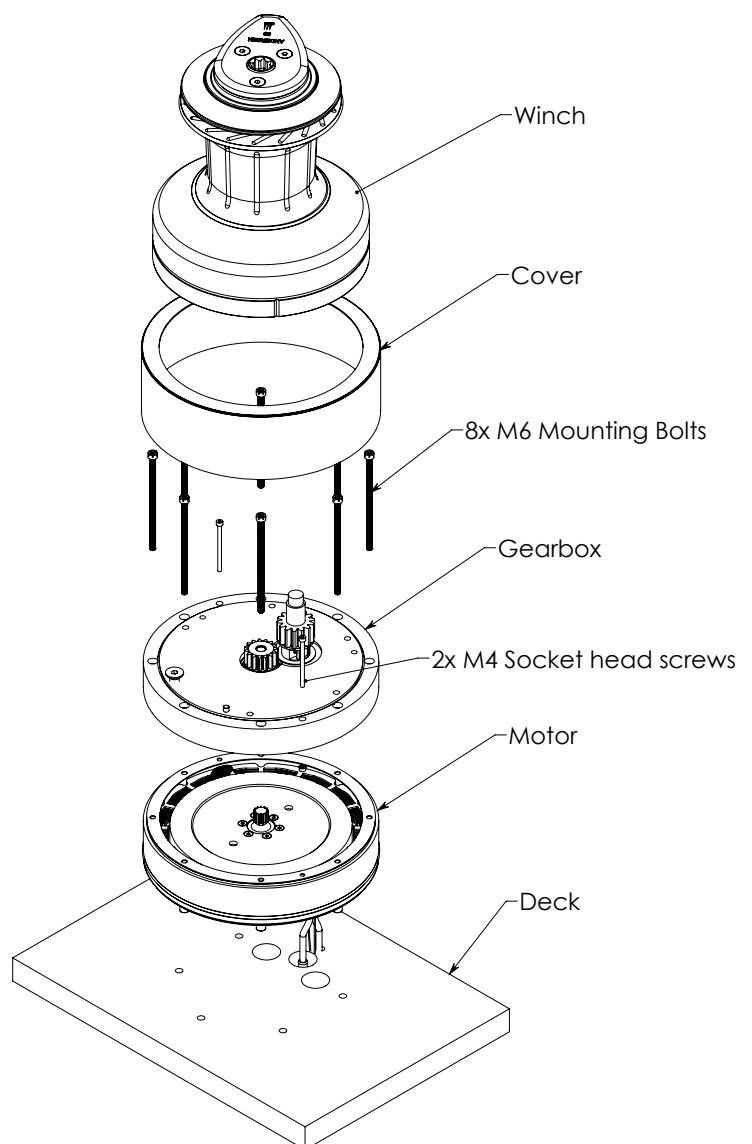

STEP 1

Make a reference mark to facilitate re-assembly.

Before disassembling the motor/gearbox unit, make a reference mark as shown to facilitate re-assembly.

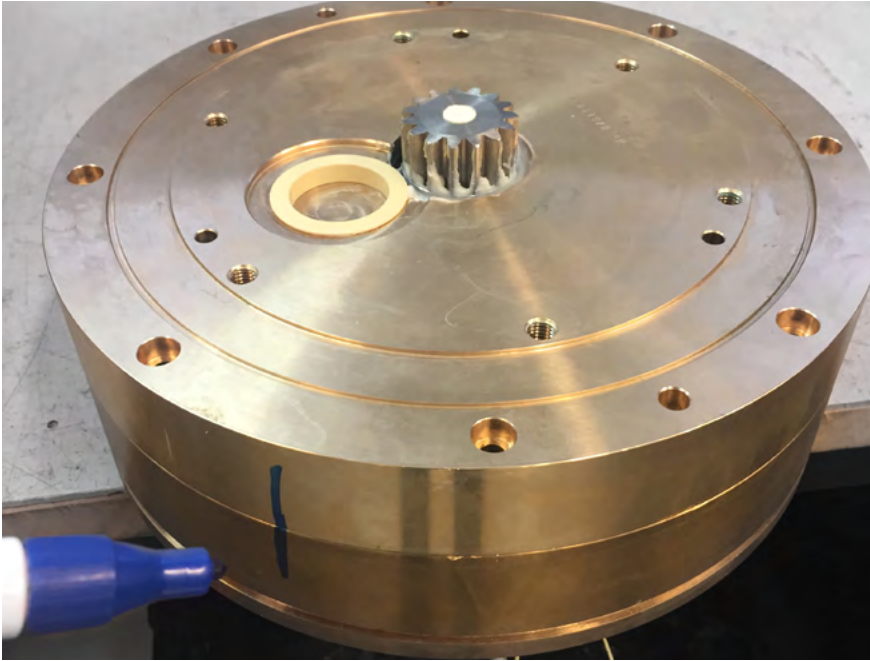

Mark across gearbox and motor

STEP 2

Remove screws joining gearbox to motor.

Remove the 2x M4 socket head screws that hold the motor and planetary gearbox together.

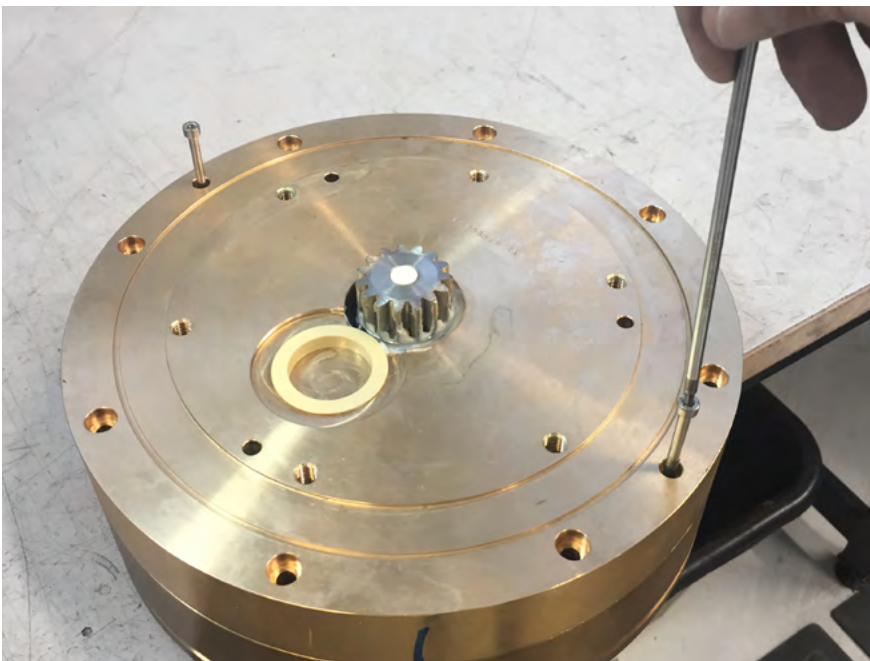

2x M4 socket head screws

STEP 3

Separate the gearbox from the motor.

Gently separate the gearbox from the motor with the help of with a flat screwdriver, tapping gently with a soft hammer. Lift the gearbox clear of the motor and place it on a flat, steady surface.

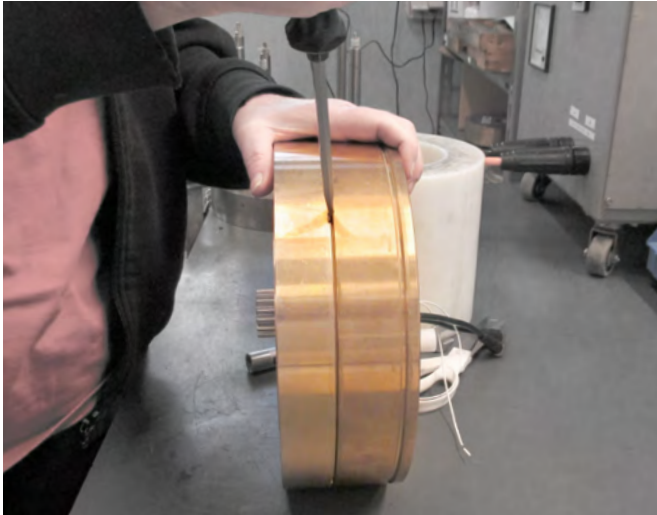

STEP 4

Clean the motor unit.

Remove and discard the old gasket. Gently scrape away any remaining adhesive residue, taking care not to let any particles fall into the motor. Using a soft dry cloth or tack cloth, with no degreaser or spirits, remove any dirt or grease from the exposed inside surfaces of the motor unit. Take extreme care not to damage the teeth of the stainless steel planetary drive gear.



Take extreme care not to damage the teeth of the stainless steel planetary drive gear.

STEP 5

Remove the gearbox glide bushing.

Turn the gearbox with drive gear facing up. Remove the glide bushing, part no. 877200 to allow full access to the lip seal. If the glide bushing is damaged, replace it during re-assembly with the new one, part number 877200 (provided in the Service Kit).

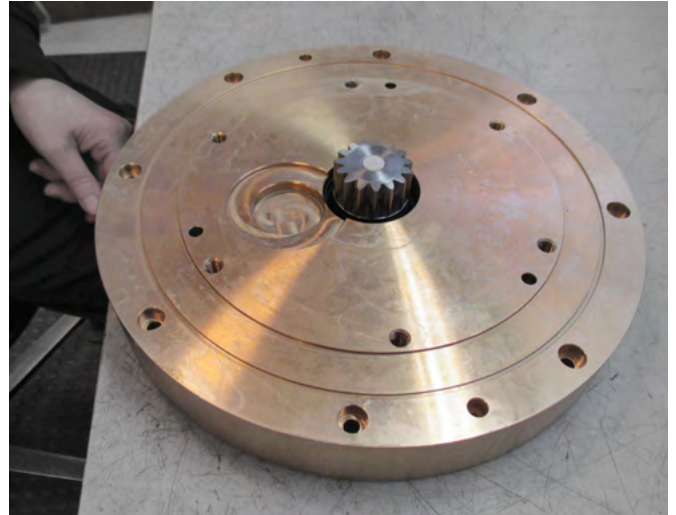
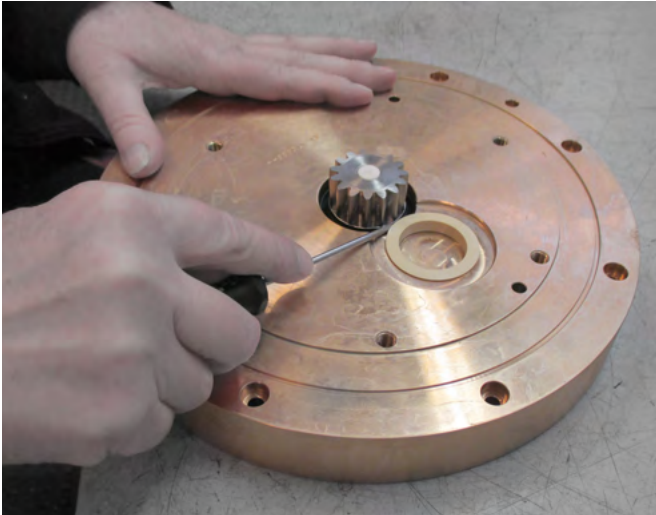

Glide bushing

STEP 6

Clean the gearbox.

Wipe the gearbox surfaces and the planetary gears clean of dirt and grease using a soft cloth and a degreaser.

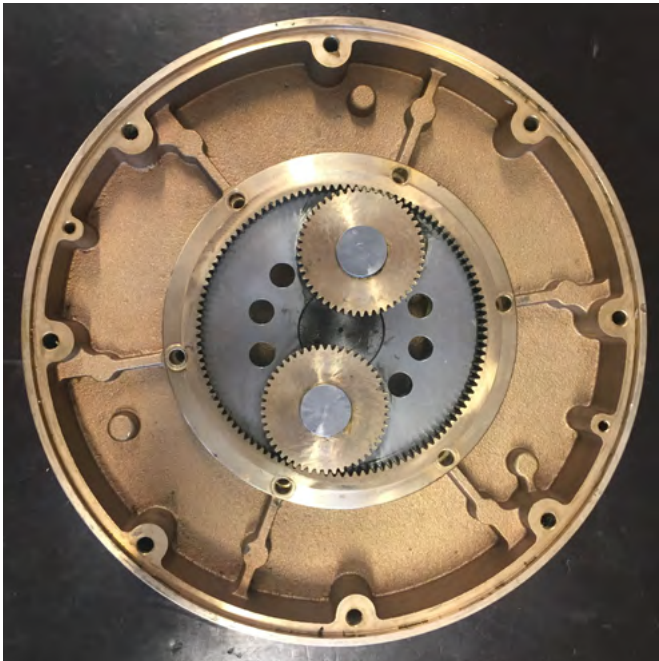

STEP 6 continued

With the open side facing up, place the gearbox on a pair of support blocks so that it is not resting on the drive gear. The support blocks should be 12mm wide x 40mm high x 250mm long - a pair may be ordered separately, as part number 821811. The support blocks must be sufficiently close together to support the central gearbox cover plate and prevent it from dropping down onto the workbench. Supporting the gearbox at this height will allow the planetary drive gear unit to be removed later without losing the ball bearings (see next steps).

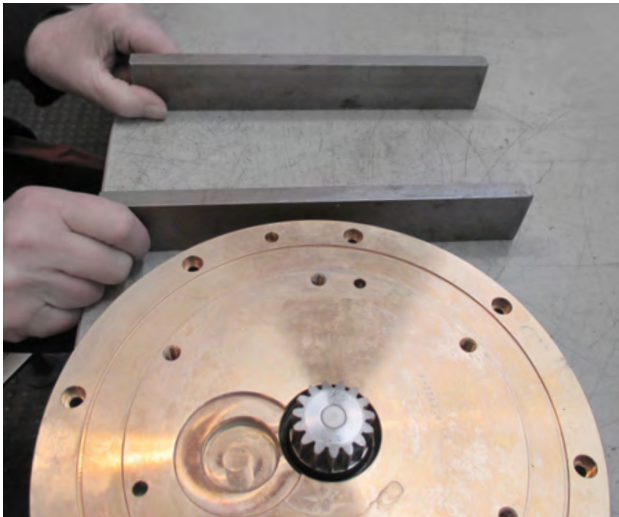

Place gearbox open side facing up

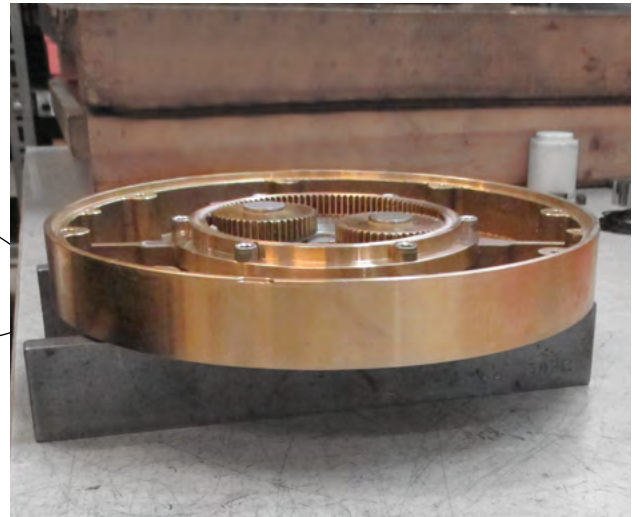

STEP 7

Remove gear ring.

With the gearbox resting firmly on the support blocks, remove the 6x M6 socket head screws and then remove the gear ring.

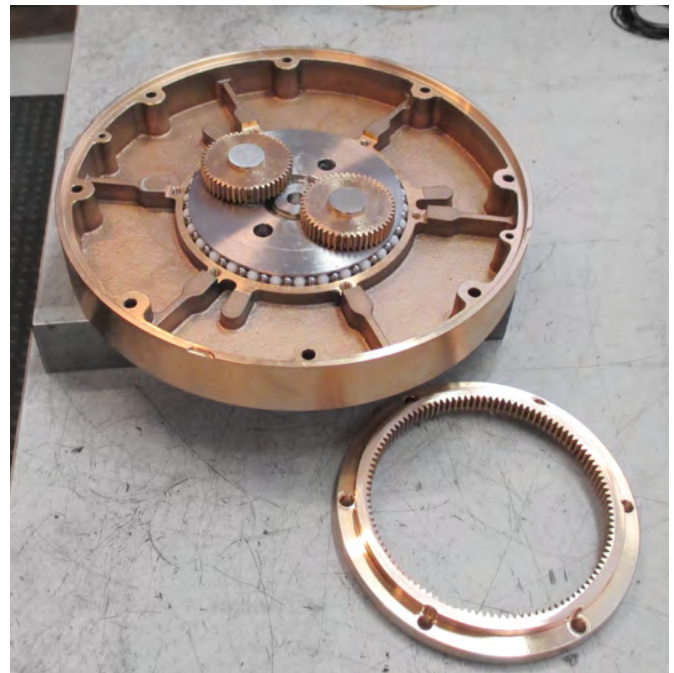
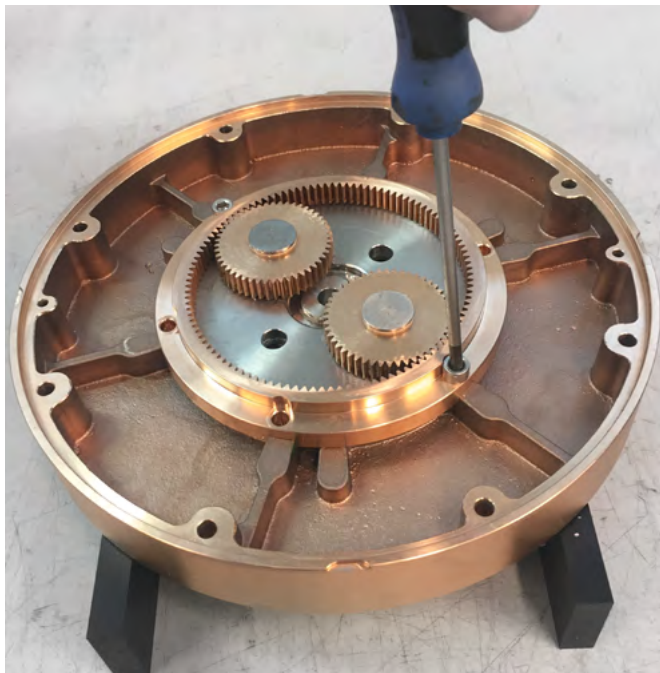

Gear ring removed

STEP 8

Remove ball bearings and planetary drive gear unit.

While holding onto the drive gear from below with your hand, tilt the gearbox very slightly and carefully perform the following actions in sequence:

1. Carefully remove the balls and put them in a safe place. There are 30 stainless steel balls and 30 acetal balls.
2. Remove the planetary drive gear unit (with the planetary gears attached).

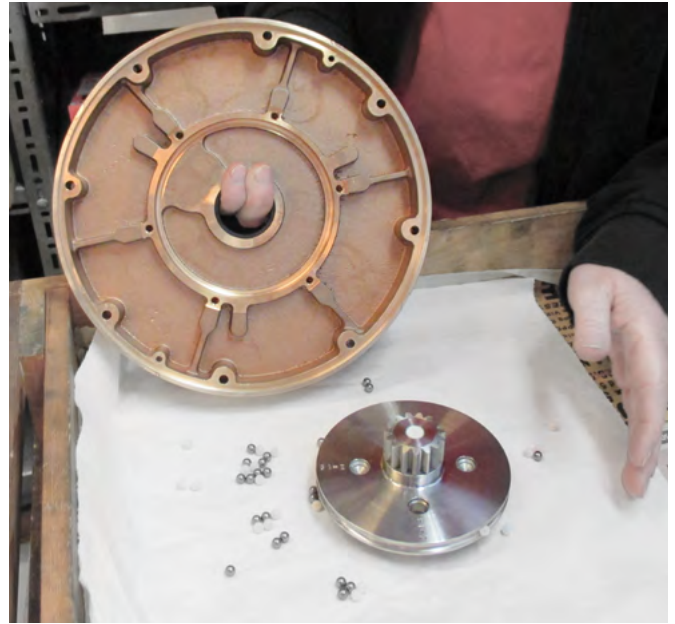
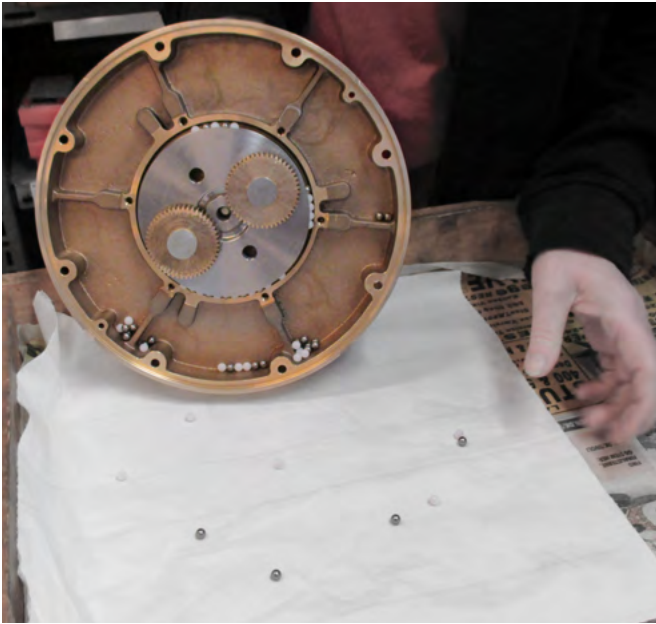

Ball bearings and drive gear unit removed

STEP 9

Remove the old lip seal.

Remove the old lip seal by prying it out with the help of a flat screwdriver, taking care not to scratch or gouge the metal surface around it. The seal will be damaged/destroyed during this operation and can not be re-used. Clean the recess in the gearbox cover plate thoroughly after removing the old lip seal.

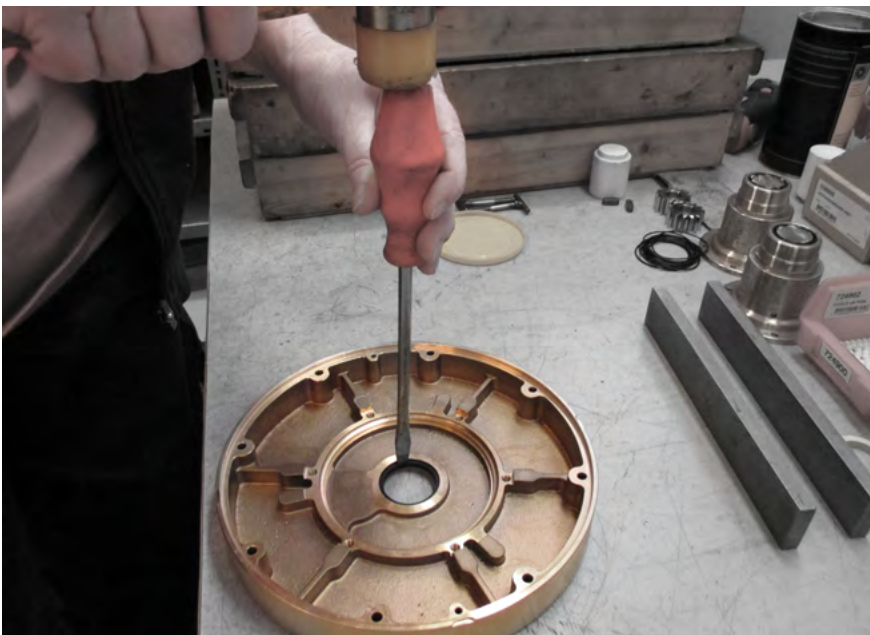

Remove the old lip seal and clean the recess

STEP 10**Fit the new lip seal.**

Locate the new lip seal, part number RD100469 (provided in the Service Kit). With its open groove facing up, align the lip seal accurately with the recess in the gearbox cover plate and gently press it completely into the recess so that it remains perfectly flush with the external surface of the gearbox. Do not use any grease during this step.

The optional mounting tool, part number 821810, can be used to help fit the lip seal.

- 1 Check which end of the tool has the correct diameter to fit your lip seal. Place the new lip seal, with its open groove facing up, onto that end of the tool.
- 2 Use the tool to insert the seal into the recess. The end of the tool will fit in the hole, accurately aligning the seal as it is inserted.
- 3 Tap with the help of a soft hammer to fit the seal perfectly and completely into position, flush with the external surface of the gearbox.
- 4 The seal must be perfectly flush with the cover plate, otherwise the drive gear and attached planetary gears will not engage properly when re-assembled.

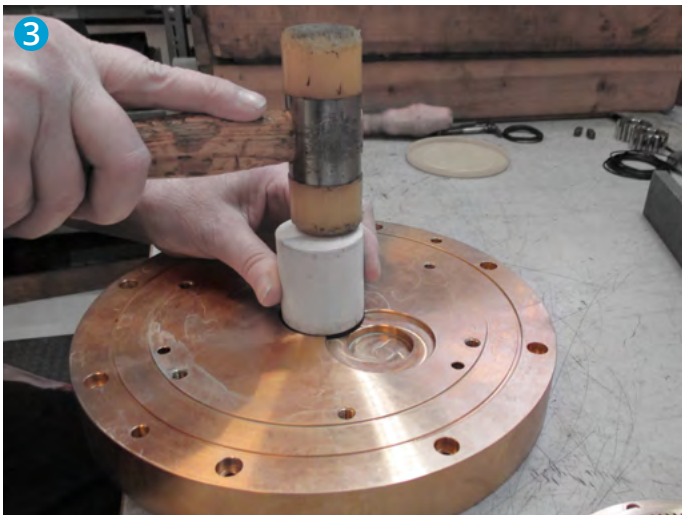

STEP 11

Grease lip seal and adjacent surfaces.

Locate the TOPAS NB52 grease, part number 980700 (provided in the Service Kit), and apply grease liberally to the lip seal and the base of the drive gear.

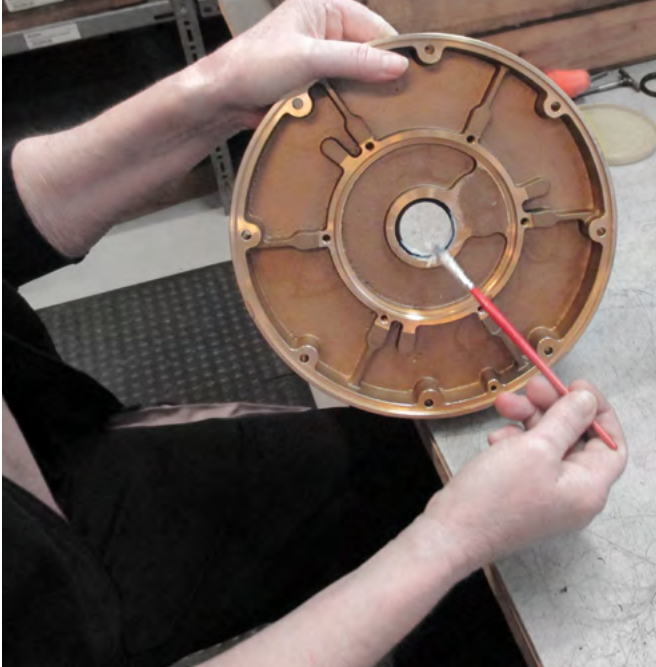

Lip seal

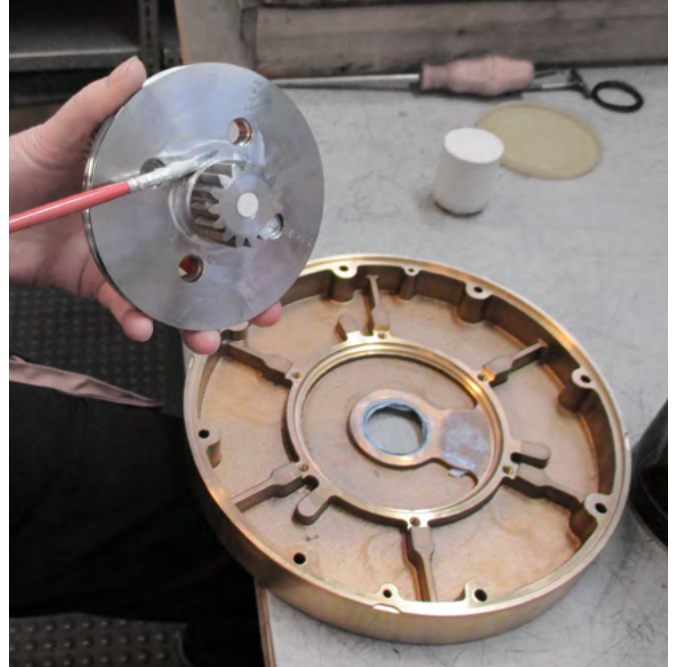

Base of the drive gear

STEP 12

Insert planetary drive gear unit and prepare to load ball bearings.

Place the gearbox face up on supports to hold it 12mm above the work table, then carefully insert the drive gear with attached planetary gears – it will sit slightly proud, allowing for easy loading of the ball bearings.

Note: The supports must be 12mm thick to position the ball race correctly for loading of the ball bearings.

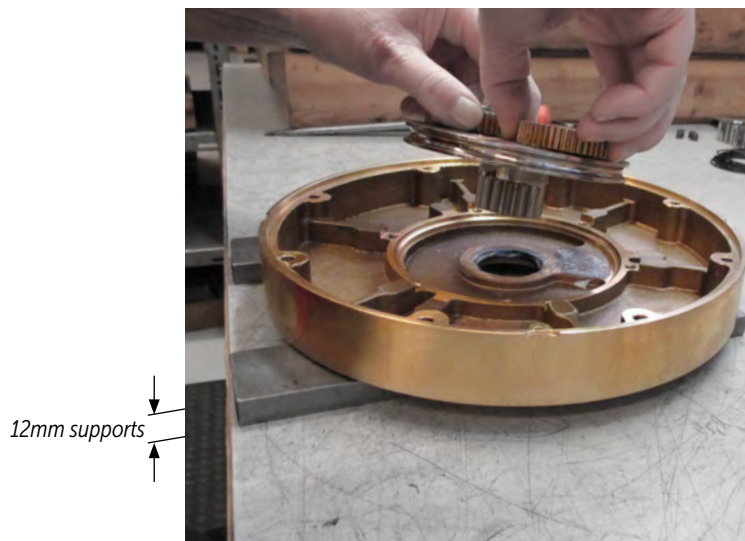

12mm supports

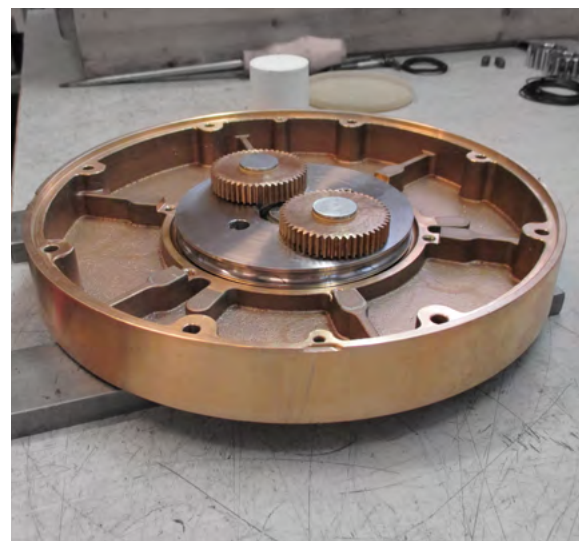

Ball race ready for loading

STEP 13

Load ball bearings.

Place stainless steel balls in the ball race, then insert the white acetal balls between them so the stainless balls do not touch each other. There are 30 stainless steel ball and 30 acetal balls – four spares of each are provided in the Service Kit (724900 & 724902). For best results be patient and go slowly, placing the balls gently into position.

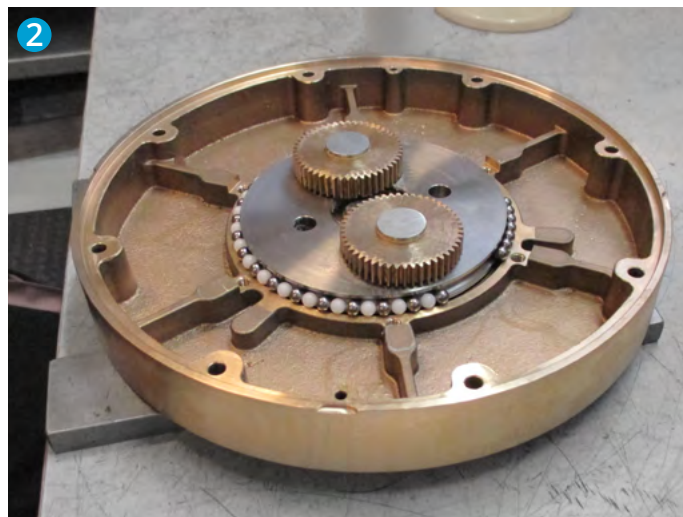
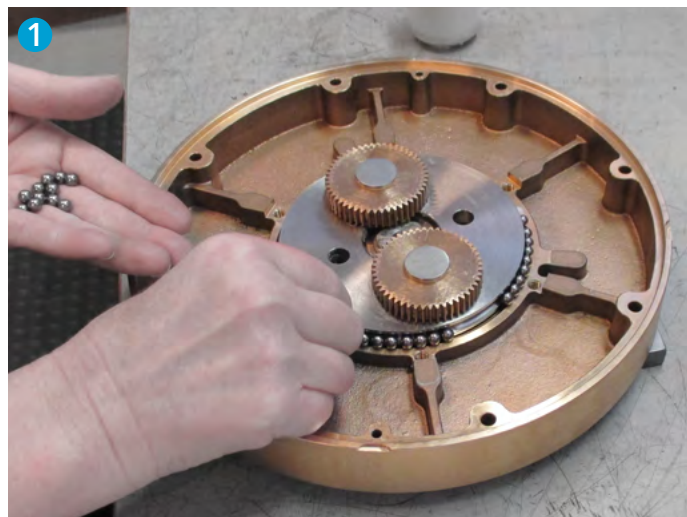

When all balls are loaded, lift the gearbox directly upward, allowing the planetary drive unit to drop into position and correctly retain the ball bearings. Now place the gearbox again on the supports, this time on their longer side as shown. The gearbox will sit 40mm above the workbench so that the drive gear underneath is not touching.

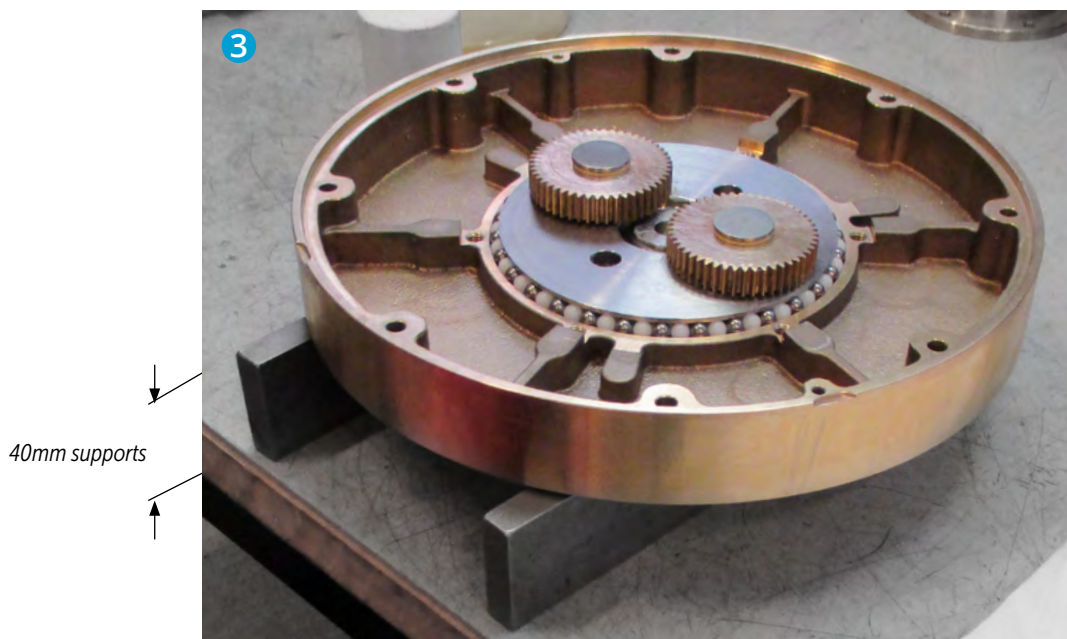

STEP 14

Lubricate ball bearings.

Using a small brush, apply Andersen Winch Grease (part no. RA500001-1) to the ball bearings.

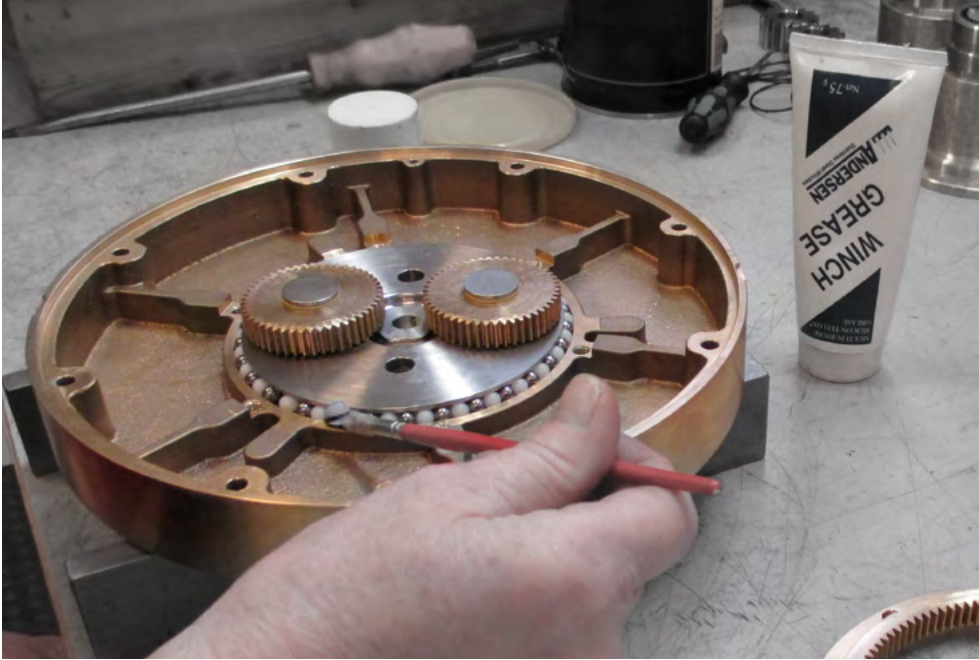

STEP 15

Re-assemble planetary gear ring and lubricate.

1. Place the gear ring in position (recesses for socket head screws facing up).
2. Secure with the 6x M6 socket head screws. Use a drop of threadlock, medium strength, on each screw.
3. Locate the TOPAS NB52 grease, part number 980700 (provided in the Service Kit), and apply a layer on the cleaned internal gears.
4. Rotate the gears by hand – they should rotate smoothly without binding.

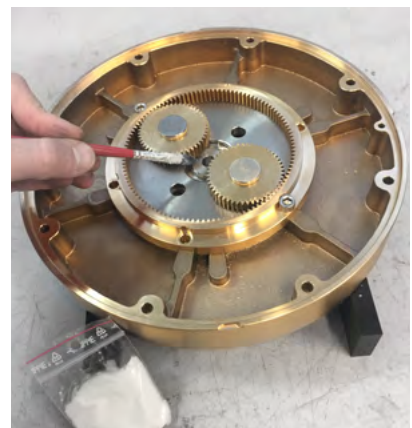
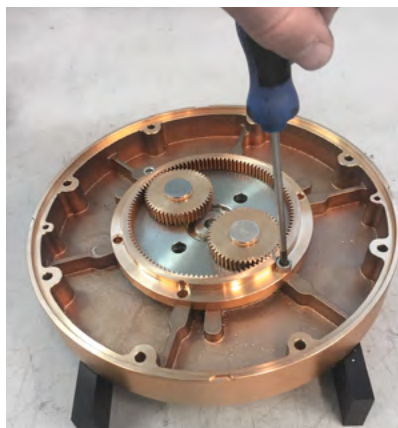

STEP 16

Replace gasket on motor 821900 / 822000.

Locate the new gasket: part number 821900 for 46-50ST or 822000 for 52-58-62ST (provided in the Service Kit). Ensure that the mounting surface is clean and free of any residue from the old gasket. Place the new gasket in position with the adhesive side down, taking care to align the hole locations before peeling off the backing paper from the adhesive side.

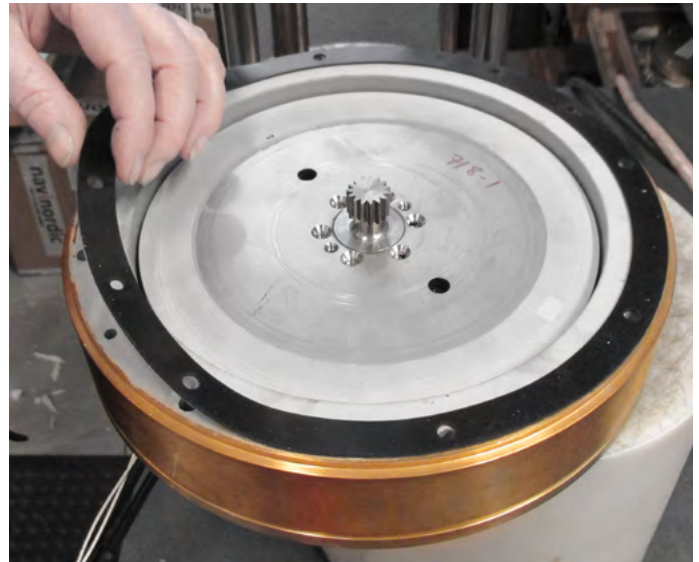
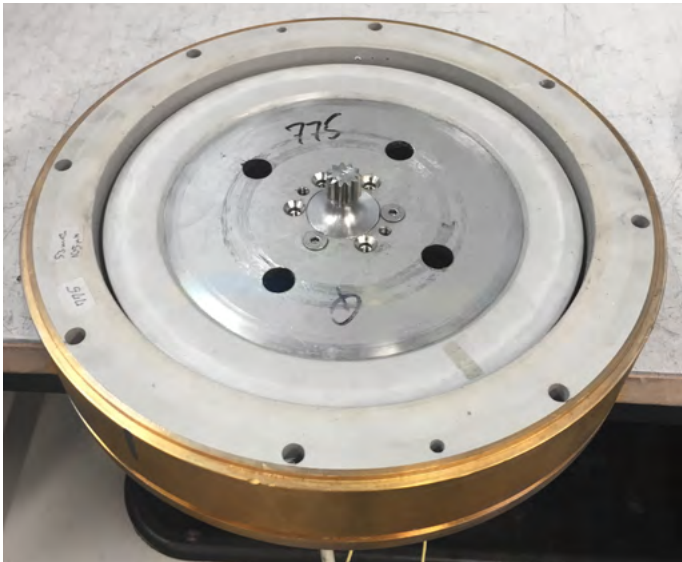
**STEP 17**

Re-assemble gearbox and motor, grease the lip seal.

- 1 Position the gearbox above the motor with the drive gear facing up, using your original alignment marks as a reference. Lower the gearbox into position – you may need to gently rock the assembly to allow the planetary gears to engage as the gearbox drops into position.
- 2 Insert and tighten the 2x M4 socket head screws to secure the motor/gearbox assembly.
- 3 Liberally apply TOPAS NB52 grease to the lip seal.

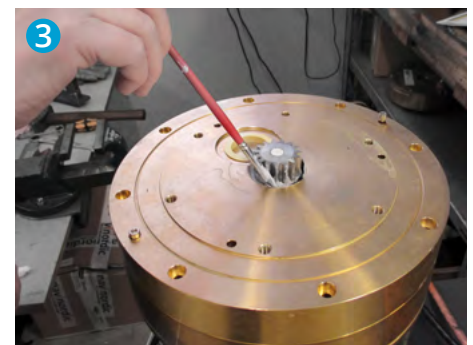
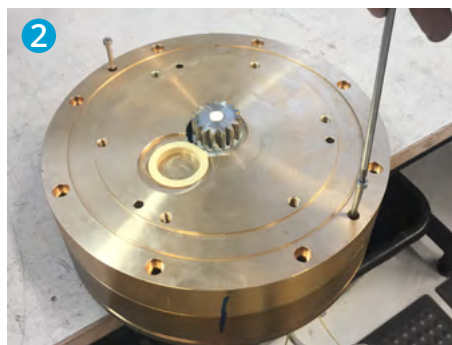
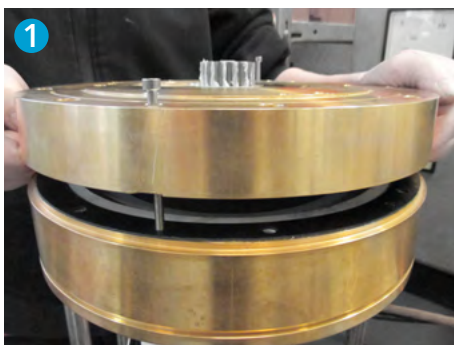

STEP 18

Replace Outer O-Ring.

Locate the new O-ring, part number RD877504 for 46-50ST or RD877505 for 52-58-62ST (provided in the Service Kit). Fit the new O-ring and apply a layer of Andersen Winch Grease.

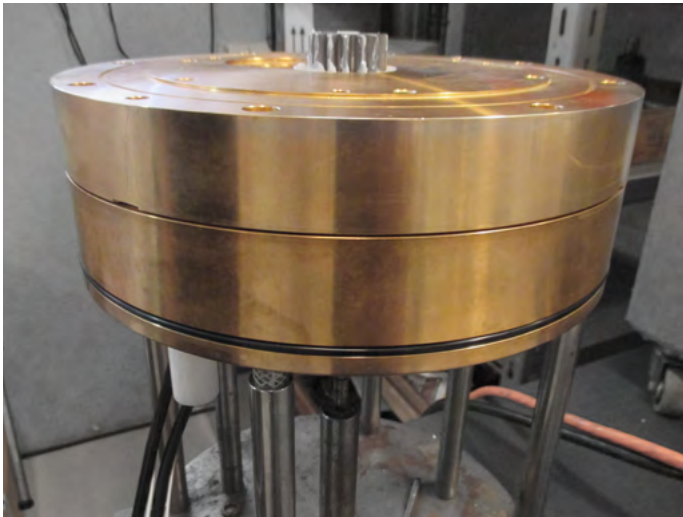

STEP 19

Replace Top O-Ring.

Apply Andersen Winch Grease to the recess on the top surface of the gearbox. Locate the new O-ring, part number RD877509 for 46-50ST or RD877502 for 52-58-62ST (provided in the Service Kit). Fit the new O-ring in position.

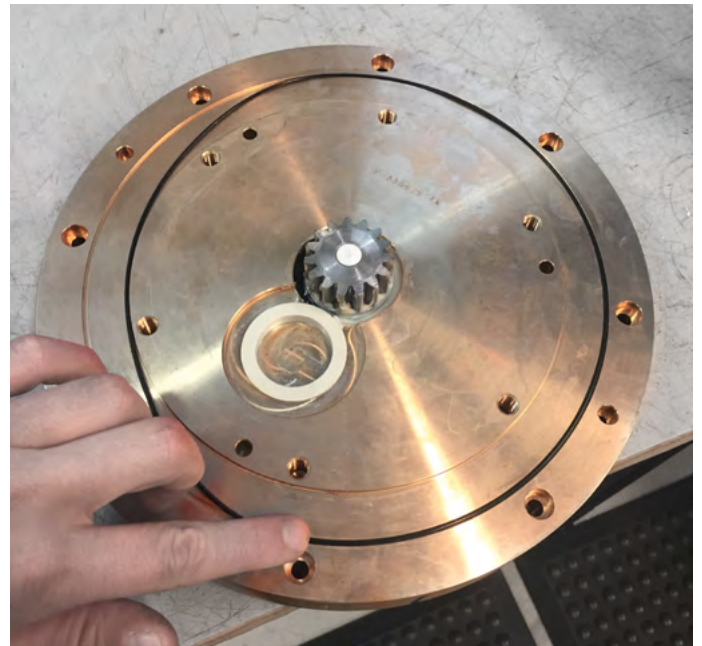

Apply Andersen Winch Grease to O-ring recess

STEP 20

Re-install motor/gearbox unit.

Secure the motor/gearbox unit to the deck with the 8x M6 mounting bolts. Connect push button and power cables, taking care to maintain correct polarity. **Note: incorrect connection of power cables will permanently damage the motor.** See the Compact Motor™ Electric Winch Product Manual for further information (available for download from our website at andersenwinches.com).

Connect power to the motor and test by running at half speed for a few seconds. The motor and gearbox operation should be smooth and quiet.



Safety First! Disconnect power from the motor again before proceeding to the next step.

STEP 21

Fit stainless steel cover and re-install winch.

Slide the stainless steel base cover down over the motor/gearbox unit and re-install the winch on top of the gearbox.

- Test the winch by spinning the drum by hand and operating the winch manually with a handle. The winch should operate smoothly in both gears.
- Connect power to the motor and test the winch with no rope and no load. It should operate smoothly.

Congratulations! You have completed an important maintenance procedure, and your Compact Motor™ electric winch is now ready to deliver many more seasons of enjoyable sailing.

Notes

Contact

Andersen Stainless Steel Winches® are manufactured by Ronstan Denmark ApS.

Jægervænget 36
7100 Vejle
Denmark

www.ronstan.com/andersen-winch
office@ronstan.com.au