



Dickinson Marine (1997) Ltd

407-204 Cayer Street

Coquitlam, B.C. Canada

V3K 5B1

www.dickinsonmarine.com

dmarine@dickinsonmarine.com



NEWPORT SOLID FUEL HEATER

INSTALLATION AND OPERATING MANUAL

This manual **MUST** be read carefully

QUALITY INSPECTED BY- Doug & Don

DATE- July 30/2008

WARNINGS AND DISCLOSURES

1

DO NOT ATTEMPT TO BURN OIL FUELS OR GAS FUELS IN THIS APPLIANCE

CERTAIN BRANDS OF ENGINEERED FIREWOOD BURN WITH AN ENHANCED LEVEL OF HEAT. READ THE INSTRUCTIONS CAREFULLY AND REFRAIN FROM BURNING ANY MANUFACTURED WOOD WITH AN ARTIFICIALLY INCREASED BTU RATING.

THIS HEATER HAS BEEN DESIGNED TO HEAT A SMALL AREA OR AS AN ESTHETIC FEATURE FOR YOUR BOAT. USE THIS HEATER RESPONSIBLY. DO NOT OVERFILL THIS HEATER.

WHEN USING ENGINEERED FIREWOOD, MORE FREQUENT CLEANING OF THE FIREBOX AND THE FLUE MAY BE REQUIRED.

FOLLOW ALL INSTALLATION AND OPERATING PROCEDURES

A PERMANENTLY OPEN FRESH AIR INLET MUST BE INSTALLED TO ALLOW AIR TO ENTER THE BOAT AND PROVIDE COMBUSTION AIR FOR THE HEATER

WARNING: THIS APPLIANCE AND THE EXHAUST PIPE GETS HOT DURING OPERATION. CARE SHOULD BE TAKEN TO PREVENT INJURY.

DO NOT OPERATE THIS PRODUCT UNATTENDED

LIGHTING INSTRUCTIONS

1. **Open the air damper control located on the front of the ash drawer by sliding the knob to the right side.**
2. **Close the sliding panel on the front door by unscrewing the brass thumb screw and sliding the decorative panel down.**
3. **Open the heater door and load a fire lighter or starter onto the fire grate. Ignite and add sufficient solid fuel for the fire to start. It is important not to overfill the combustion chamber.**
4. **Close the door.**
5. **Once the fire is established the sliding panel may be opened**
6. **The air damper control can be adjusted to provide fast or extended burning.**

RECOMMENDED INSTALLATION REQUIREMENTS
NEWPORT SOLID FUEL HEATER

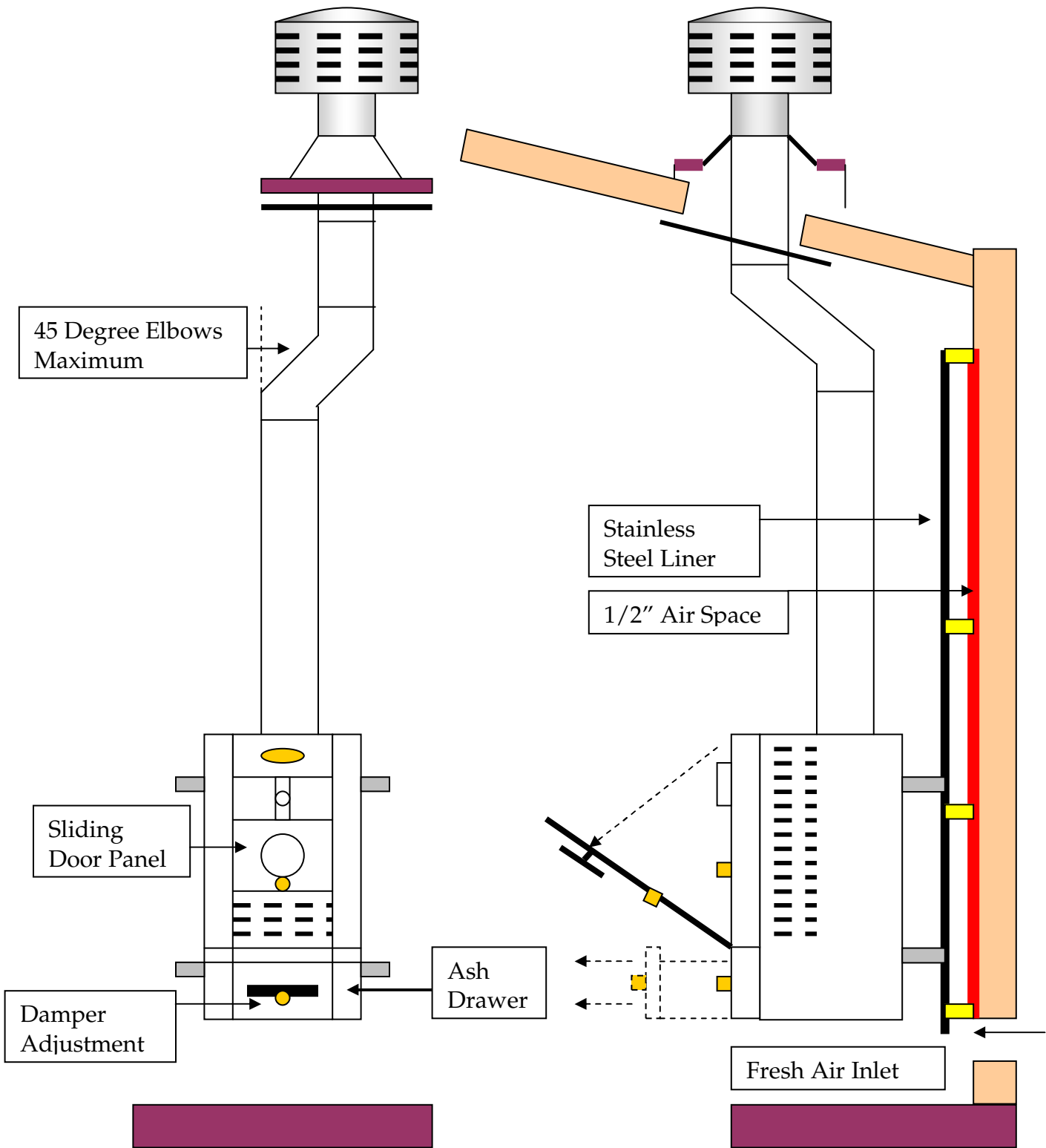

LOCATION

The Newport solid fuel should be mounted on a bulkhead. The area available must be large enough to allow at least 8” of side clearance from combustible surfaces. It must be lined with high-density heat retardant insulation and finished with a light gauge metal preferably stainless steel. Locate the heater as close to the floor as possible for maximum stack length and to provide good heat convection. The location must also take into consideration stack configuration and insure that the chimney above deck is clear of any obstruction.

MOUNTING AND SECURING

Screw or bolt the heater to the stainless steel panel on the bulkhead using the rear mounting brackets provided.

FLUE STACK

The length and straightness of the flue stack are important to the efficient burning of the heater.

Diameter - 3” (7.82cm)
Recommended length - 3 to 4 ft (.91 to 1.21m)

Note The stack must be the correct diameter.

The flue pipe requires 1” (25mm) of clearance as it rises through the deck.

Elbows in excess of 45 degrees not recommended.

A barometric damper is highly recommended to slow the burning but keep the draft strong. A manual flue damper is also available but is only recommended when installed in a very short chimney length otherwise a barometric damper is the best.

THE ROUND PIPE IS SQUEEZED TO FIT THE OVAL FLUE COLLAR ON THE HEATER

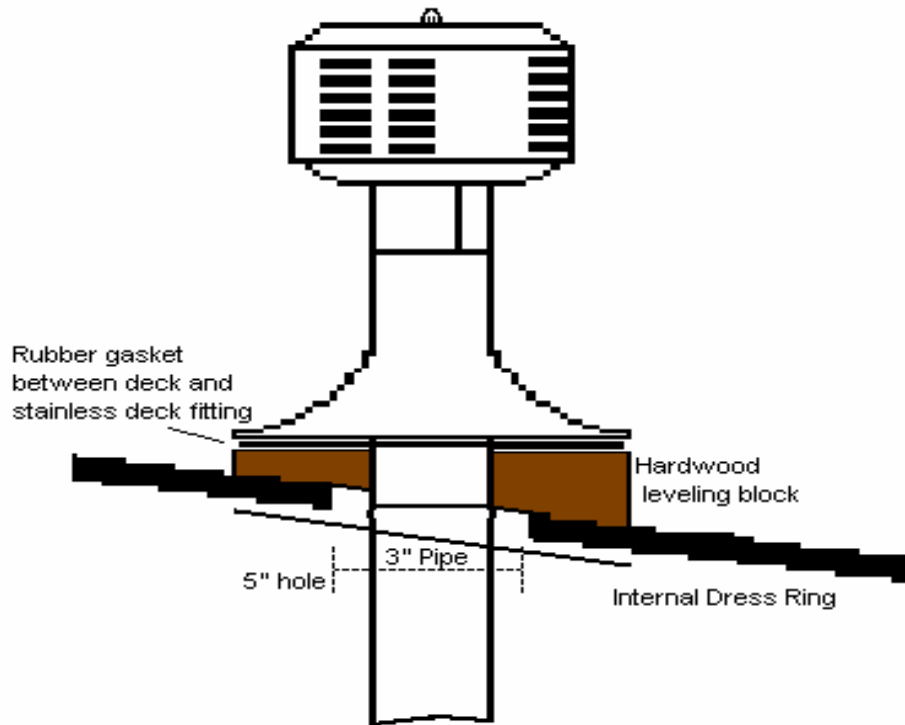

FLUE CAP

The Dickinson DP Cap (Prt#16-080) or the Dickinson "H" Cap (Prt#16-090) is recommended.

COMBUSTION AIR

To guarantee that sufficient oxygen (fresh air) is available for your heater **GOOD VENTILATION IS ESSENTIAL**. It is necessary to replace the air inside your boat at the same rate as it is being consumed by the heater. **THE HOTTER THE HEATER THE MORE AIR IT WILL REQUIRE**. As most boats are relatively airtight **A SEPARATE, PERMANENTLY OPEN FRESH AIR INLET IS RECOMMENDED**. This inlet must be at least 3" in diameter.

It is important to maintain a positive pressure inside the boat. High winds can draw air from the boat and create a negative internal pressure. This condition can cause downdrafts.

FUELS

Wood, charcoal briquettes or similar solid fuels can be burned. Slow burning fuels are recommended. The use of pressed artificial fire wood may require more frequent cleaning of the exhaust pipe and cap. **Care must be taken not to overfill the combustion chamber.**

Lighting

- 1) Open the damper control on the front of the ash drawer by sliding the brass knob to the right.
- 2) Close the sliding panel on the front door of the heater.
- 3) The fire can be lit using any fire lighter or starter. **IT IS IMPORTANT NOT TO OVERFILL THE COMBUSTION CHAMBER.**
- 4) Once the fuel has ignited the sliding panel may be opened and the damper control adjusted to provide extended burning. (Note : Both the knob of the sliding door and the damper are hot and hand protection must be worn to make any adjustment when the heater is burning)

WARNING
PROVIDE AMPLE FRESH AIR
HEATER AND EXHAUST PIPE BECOMES HOT
BURN ONLY THE INTENDED FUELS IN THIS HEATER
DO NOT BURN THE HEATER IF WINDY CONDITIONS ARE CAUSING
DOWNDRAFTS

WARNING : DO NOT OPERATE UNATTENDED

NEWPORT SOLID FUEL

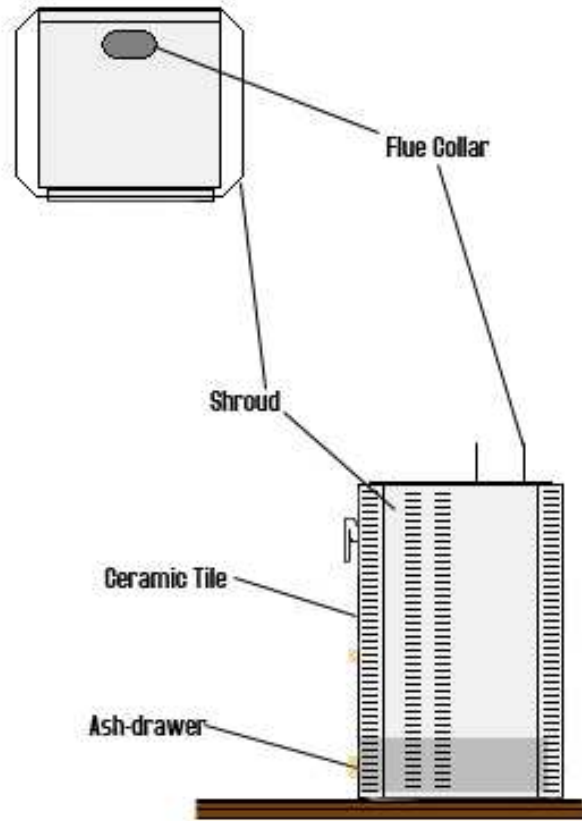

PARTS LIST

- 05-010 - Firegrate
- 05-080 - Ceramic Tile
- 07-090 - Stainless Top
- 08-030 - 3" Flue Collar
- 14-070 - Reamer Rod
- 14-090 - Thumb Screw

LIMITED WARRANTY

WARRANTY PROVISIONS : dickinson warrants this product to be free of defects in workmanship and materials for a period of one year. This warranty is limited to claims submitted in writing within a one-year period following the date of purchase. If any part of your new product fails because of a manufacturing defect within the warranty period dickinson offers to replace said parts free of charge, provided, **however, that such parts have not been improperly repaired, altered or tampered with or subjected to misuse, abuse or exposed to corrosive conditions.** This warranty, however, is limited by certain exclusions, time limits and exceptions as listed below. Read these limitations and exclusions carefully.

TIME LIMIT : This warranty is given too and covers only the original purchaser. Coverage terminates one year from the date of purchase for parts replacement.

EXCLUSIONS : This warranty does not cover or include : (a) Any normal deterioration of the product and appearance of items, due to wear and/or exposure; (b) any guarantees, promises, representations, warranties or service agreements given or made by an authorized distributor or other person selling this product, other than those specifically stated herein; (c) any damage or defect due to accident, improper repair, alteration, unreasonable use including failure to provide reasonable and necessary maintenance, misuse or abuse of the equipment, or exposure to corrosive conditions. This warranty is conditioned upon normal use, reasonable and necessary maintenance and service of your product, and written notice being given promptly upon Buyer's discovery of a warranty claim, pursuant to paragraph 6 below. Reasonable and necessary maintenance is maintenance which you are expected to do yourself or have done for you. It is maintenance, which is necessary to keep your product performing its intended function and operating at a reasonable level of performance.

DAMAGE LIMITATION WARNING : IN NO EVENT SHALL dickinson BE LIABLE FOR ANY INCIDENTAL OR CONSEQUENTIAL DAMAGES, INCLUDING (BUT NOT LIMITED TO) LOSS OF USE OF THE PRODUCT, LOSS OF TIME, INCONVENIENCE, EXPENSES FOR TRAVEL, LODGING TRANSPORTATION CHARGES, LOSS BY DAMAGE TO PERSONAL PROPERTY OR LOSS OF INCOME, PROFITS OR REVENUE.

ORAL OR IMPLIED WARRANTY LIMITATIONS : The foregoing warranty is exclusive and in lieu of all other warranties, written or oral, expressed or implied, including but not limited to any warranty or merchantability or fitness for a particular purpose.

TRANSFER LIMITATIONS : This warranty is not assignable or transferable. It covers only the original purchaser.

CLAIM PROCEDURE : In the event of a defect, problem or that a breach of this warranty is discovered, in order to protect any warranty rights you must promptly notify dickinson. Give name, address, and model name, location of unit, description of problem and where you can be reached during business hours.

RESERVED RIGHT TO CHANGE : dickinson reserves the right to make changes or improvements to products it produces in the future without imposing on itself any obligations to install the same improvements in the products it has previously manufactured.

SECOND OR SUBSEQUENT OWNER : dickinson does not give any warranty to secondary or subsequent purchasers, and it disclaims all implied warranties to such owners.

INSPECTION : To assist you in avoiding problems with your product and to validate this warranty you are required to do the following : (a) read the warranty; (b) inspect the product. Do not accept delivery until you have examined the product with your supplier; (c) ask questions about anything you do not understand concerning the product.

OWNER REGISTRATION : Fill out the **WARRANTY CARD** within 30 days from the date of delivery.

WARRANTY : RETURN OF THE CARD IS CONDITION PRECEDENT TO WARRANTY COVERAGE AND PERFORMANCE. IF YOU DO NOT FILL OUT AND MAIL THE CARD AS DIRECTED, YOU WILL NOT HAVE A WARRANTY.

LEGAL RIGHTS : This warranty gives you specific legal rights and you may also have other rights, which may vary within different government jurisdictions.

Return to:



SINCE 1932

#407 – 204 Cayer Street, Coquitlam, B.C. Canada V3K 5B1

WARRANTY FORM

I have read and understand the Limited Warranty and the Instruction Manual
and agree to the terms and conditions

(please print)

Date.....

Purchaser's Name.....

Address.....

.....

.....

Model Name.....**Newport Solid Fuel**.....

Date Of Purchase.....

Signature.....

Name of Seller.....

Seller Location.....

Note: The warranty form can be filled out and sent from the
website: www.dickinsonmarine.com