

## *Installation Manual* **RADAR SENSOR** **DRS2D/DRS4D/** **DRS4A/DRS6A/DRS12A/DRS25A**

---

<b>SAFETY INSTRUCTIONS .....</b>	<b>i</b>
<b>SYSTEM CONFIGURATION .....</b>	<b>ii</b>
<b>EQUIPMENT LISTS.....</b>	<b>iv</b>
<b>1. MOUNTING .....</b>	<b>1</b>
1.1 Mounting Considerations.....	1
1.2 Mounting Procedure for DRS2D/4D .....	2
1.3 Mounting Procedure for DRS4A/6A/12A/25A.....	3
1.4 Mounting of Power Supply Unit .....	8
<b>2. WIRING .....</b>	<b>11</b>
2.1 Wiring inside DRS2D/4D .....	15
2.2 Wiring inside DRS4A/6A/12A/25A.....	19
2.3 Wiring of Power Supply Unit.....	23
<b>SPECIFICATIONS .....</b>	<b>SP-1</b>
<b>PACKING LISTS.....</b>	<b>A-1</b>
<b>OUTLINE DRAWINGS.....</b>	<b>D-1</b>
<b>INTERCONNECTION DIAGRAMS.....</b>	<b>S-1</b>







# SAFETY INSTRUCTIONS

Read these safety instructions before installing the equipment.



## WARNING

Indicates a potentially hazardous situation which, if not avoided, could result in death or serious injury.



## CAUTION

Indicates a potentially hazardous situation which, if not avoided, can result in minor or moderate injury.



Warning, Caution



Prohibitive Action



Mandatory Action



## WARNING



**Do not open the equipment unless totally familiar with electrical circuits and service manual.**

Only qualified personnel should work inside the equipment.



**Wear a safety belt and hard hat when working on the antenna unit.**

Serious injury or death can result if someone falls from the radar mast.



**Construct a suitable service platform from which to install the antenna unit.**

Serious injury or death can result if the power is left on or is applied while the equipment is being installed.



**Turn off the power at the mains switch board before beginning the installation.**

Fire, electrical shock or serious injury can result if the power is left on or is applied while the equipment is being installed.



## CAUTION



**Ground the equipment to prevent electrical shock and mutual interference.**

**Observe the following compass safe distance to prevent deviation of a magnetic compass.**

Model	Standard	Steering
DRS4A	0.80 m	0.50 m
DRS6A	0.85 m	0.55 m
DRS12A	1.15 m	0.70 m
DRS25A	1.00 m	0.60 m
DRS2D	1.35 m	0.80 m
DRS4D	1.40 m	0.85 m
PSU-012	0.30 m	0.30 m
PSU-013	0.30 m	0.30 m
PSU-017	0.30 m	0.30 m



## WARNING



### Radio Frequency Radiation Hazard

The radar antenna emits electromagnetic radio frequency (RF) energy which can be harmful, particularly to your eyes. Never look directly into the antenna aperture from a close distance while the radar is in operation or expose yourself to the transmitting antenna at a close distance.

Distances at which RF radiation levels of 100 and 10 W/m<sup>2</sup> exist are given in the table below.

**Note:** If the antenna unit is installed at a close distance in front of the wheel house, your administration may require halt of transmission within a certain sector of antenna revolution. This is possible - Ask your FURUNO representative or dealer to provide this feature.

Model	Distance to 100 W/m <sup>2</sup> point	Distance to 10 W/m <sup>2</sup> point
DRS4A	Nil	1.20 m
DRS6A	Nil	1.20 m
DRS12A (XN12A)	0.20 m	2.40 m
DRS12A (XN13A)	0.20 m	1.90 m
DRS25A (XN12A)	0.50 m	5.30 m
DRS25A (XN13A)	0.40 m	4.40 m
DRS2D	Nil	0.40 m
DRS4D	0.10 m	1.40 m

# SYSTEM CONFIGURATION

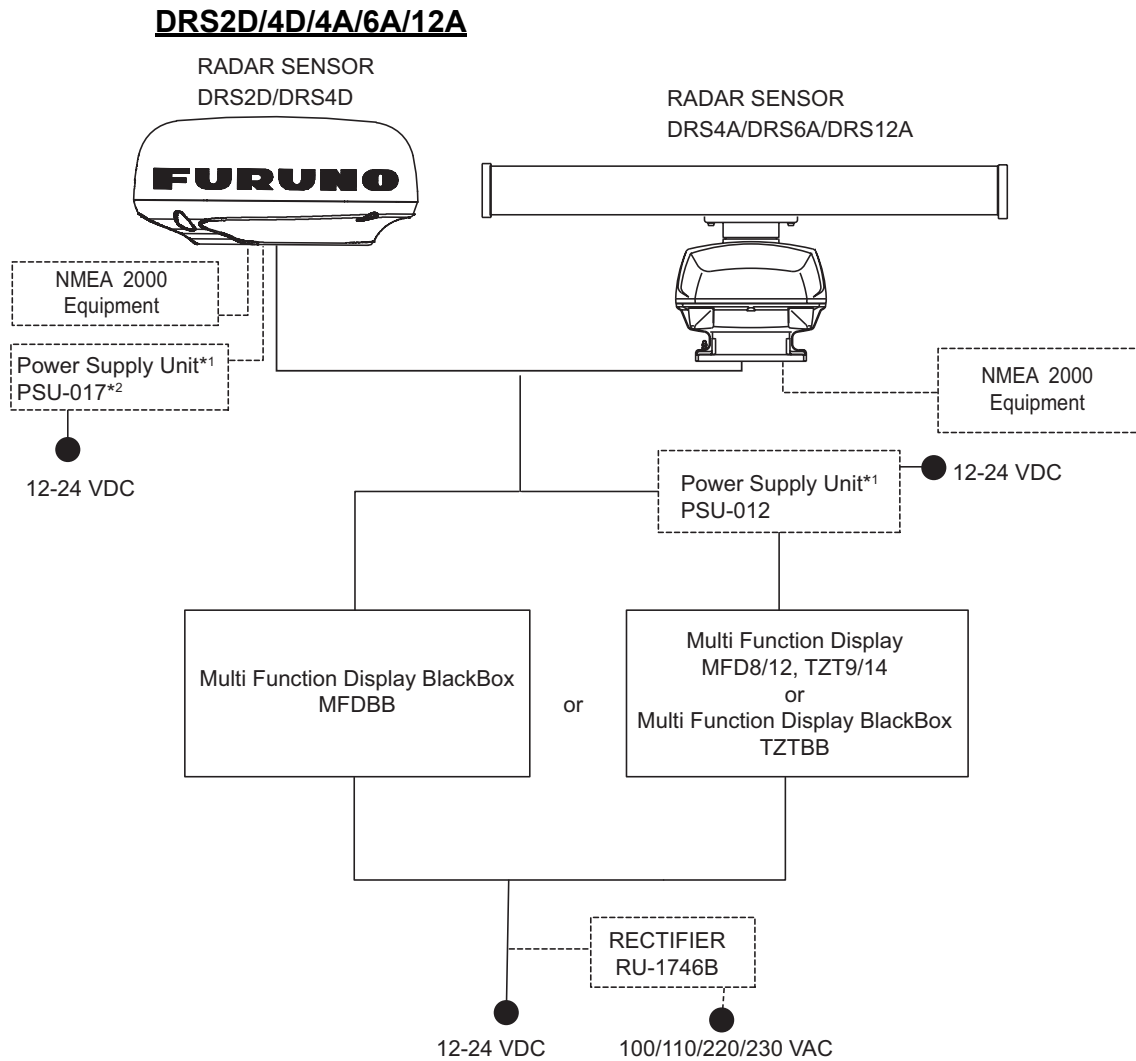

\*1: The power supply unit (PSU-012/017) is necessary in the combination of radar sensor and multi function display.

	DRS2D/4D	DRS4A	DRS6A	DRS12A
MFD8	NO	<b>PSU-012</b>	<b>PSU-012</b>	<b>PSU-012</b>
MFD12	NO	NO	NO	<b>PSU-012</b>
MFDBB	NO	NO	NO	NO
TZT9	<b>PSU-012 or PSU-017</b>	<b>PSU-012</b>	<b>PSU-012</b>	<b>PSU-012</b>
TZT14	<b>PSU-012 or PSU-017</b>	<b>PSU-012</b>	<b>PSU-012</b>	<b>PSU-012</b>
TZTBB	<b>PSU-012 or PSU-017</b>	<b>PSU-012</b>	<b>PSU-012</b>	<b>PSU-012</b>

\*2: The disconnecting device (breaker, etc.) is required when the power cable of PSU-017 is connected to ship's mains.

**DRS25A**

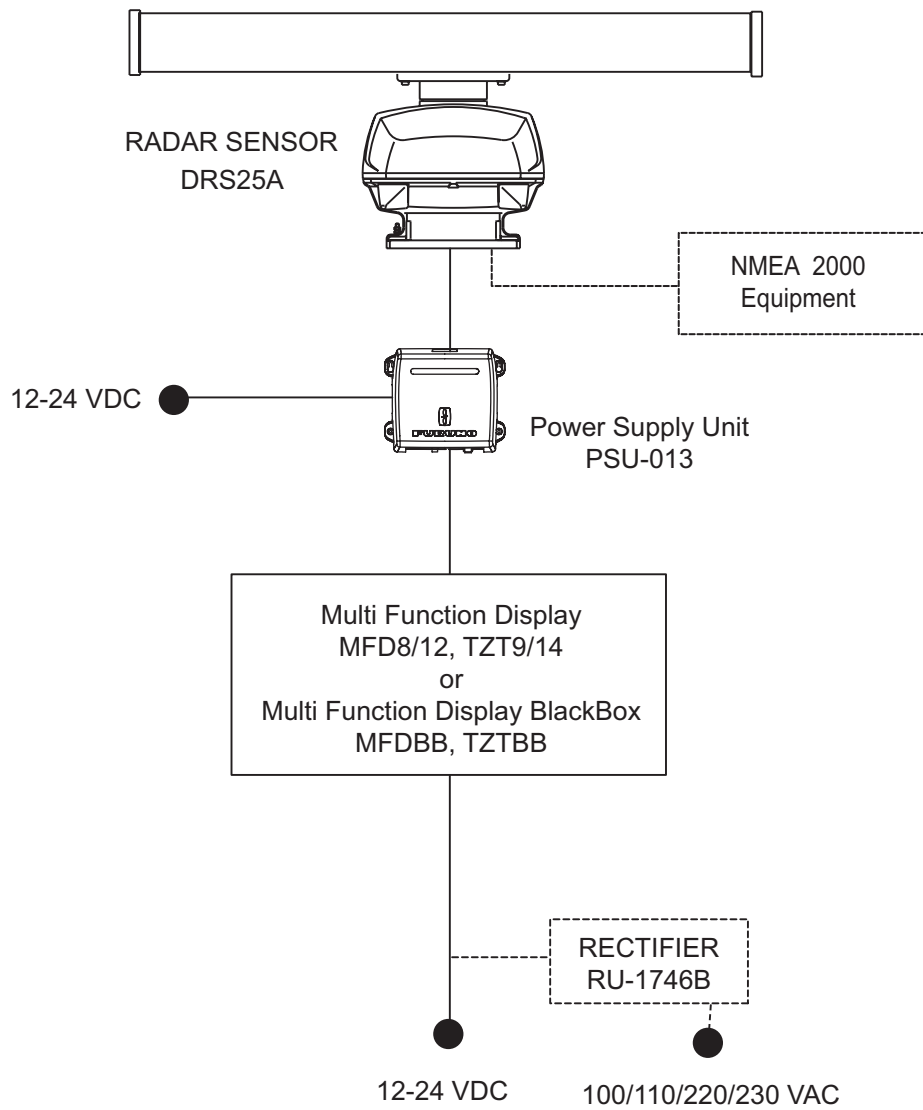

# EQUIPMENT LISTS

## Standard supply

Name	Type	Code No.	Qty	Remarks
Radar Sensor	XN10A-RSB-118-092	-	1	For DRS4A, w/CP03-32601
	XN12A-RSB-118-093		1	For DRS6A, w/CP03-32601
	XN12A-RSB-118-094	-	1	For DRS12A, 1255 mm, w/CP03-32601
	XN13A-RSB-118-094		1	For DRS12A, 1795 mm, w/CP03-32601
	XN12A-RSB-118-095	-	1	For DRS25A, 1255 mm, w/CP03-32601
	XN13A-RSB-118-095	-	1	For DRS25A, 1795 mm, w/CP03-32601
	DRS2D	-	1	Radome, 2 kW, w/CP03-32101
	DRS4D	-	1	Radome, 4 kW, w/CP03-32101
Power Supply Unit	PSU-013	-	1	For DRS25A, w/SP03-16101 and CP03-32700
Installation Materials	CP03-32101	001-025-270	1 set	For DRS2D/4D
	CP03-32601	001-025-780	1 set	For DRS4A/6A/12A/25A
	CP03-32200	000-011-720	1	Two-way cable, MOD-ASW0001-100+, 10 m, for DRS2D/4D/4A/6A/12A
	CP03-32300	000-011-721		Two-way cable, MOD-ASW0001-150+, 15 m, for DRS2D/4D/4A/6A/12A
	CP03-32400	000-011-722		Two-way cable, MOD-ASW0001-200+, 20 m, for DRS2D/4D/4A/6A/12A
	CP03-32500	000-011-723		Two-way cable, MOD-ASW0001-300+, 30 m, for DRS2D/4D/4A/6A/12A
	CP03-32800	000-011-990		Two-way cable, MOD-ASW0002-100+, 10 m, for DRS25A
	CP03-32810	000-011-991		Two-way cable, MOD-ASW0002-150+, 15 m, for DRS25A
	CP03-32820	000-011-992		Two-way cable, MOD-ASW0002-200+, 20 m, for DRS25A
	CP03-32830	000-011-993		Two-way cable, MOD-ASW0002-300+, 30 m, for DRS25A

**Optional supply**

Name	Type	Code No.	Remarks
Power Supply Unit	PSU-012	-	
	PSU-017	-	For DRS2D/4D
Gasket	OP03-203	001-025-290	For DRS2D/4D, $\phi$ 10 NMEA2000 cable
	OP03-205	001-025-790	For DRS4A/6A, $\phi$ 10 NMEA2000 cable
	OP03-206	001-035-290	For DRS25A, $\phi$ 10 NMEA2000 cable
Resister Assy	OP03-204	001-025-300	For NMEA2000 connection with a unit
Radome Mount	OP03-208	001-078-340	For DRS4D
	OP03-209	001-078-350	For DRS2D
Joint Box*	TL-CAT-012	000-167-140-10	For LAN cable extension
LAN Cable	MOD-Z072-020+	000-167-175-10	2 m
	MOD-Z072-050+	000-167-176-10	5 m
	MOD-Z072-100+	000-167-177-10	10 m
Cable Assy	M12-05BFFM-010	000-167-965-10	NMEA2000, $\phi$ 6, w/connector, 1 m
	M12-05BFFM-020	000-167-966-10	NMEA2000, $\phi$ 6, w/connector, 2 m
	M12-05BFFM-060	000-167-967-10	NMEA2000, $\phi$ 6, w/connector, 6 m
	CB-05BFFM-010	000-167-971-10	NMEA2000, $\phi$ 10, w/connector, 1 m
	CB-05BFFM-020	000-167-972-10	NMEA2000, $\phi$ 10, w/connector, 2 m
	CB-05BFFM-060	000-167-973-10	NMEA2000, $\phi$ 10, w/connector, 6 m

\*: After the wiring, it is required to wind the vinyl tape around the LAN connector to waterproof.

# 1. MOUNTING

---

## NOTICE

**Do not apply paint, anti-corrosive sealant or contact spray to coating or plastic parts of the equipment.**

Those items contain organic solvents that can damage coating and plastic parts, especially plastic connectors.

## 1.1 Mounting Considerations

- The radar sensor is generally installed either on top of the wheelhouse or on the radar mast on a suitable platform. Locate the radar sensor where there is a good all-round view. Any obstruction will cause shadow and blind sectors. A mast for instance, with a diameter considerably less than the horizontal beamwidth of the radiator, will cause only a small blind sector, but a horizontal spreader or crosstrees in the same horizontal plane as the radar sensor would be a much more serious obstruction; you would need to place the radar sensor well above or below it.
- It is rarely possible to place the radar sensor where a completely clear view in all directions is available. Thus, you should determine the angular width and relative bearing of any shadow sectors for their influence on the radar at the first opportunity after fitting.
- A magnetic compass will be affected if the radar sensor is placed too close to it. Observe the compass safe distances mentioned in the SAFETY INSTRUCTIONS to prevent interference to a magnetic compass.
- Do not paint the radiator aperture and radome to ensure proper emission of the radar waves.
- When this radar sensor is to be installed on large vessels, consider the following points:
  - The two-way cable run between the radar sensor and MFDBB, MFD8, MFD12 or PSU-012 comes in lengths of 10 m, 15 m, 20 m or 30 m.
  - Deposits and fumes from a funnel or other exhaust vent can adversely affect the aerial performance and hot gases may distort the radiator portion. The radar sensor must not be mounted where the temperature is more than 55 degrees centigrade.

As shown in the figure below, the radar sensor may be installed on a common mast or on the radar mast.

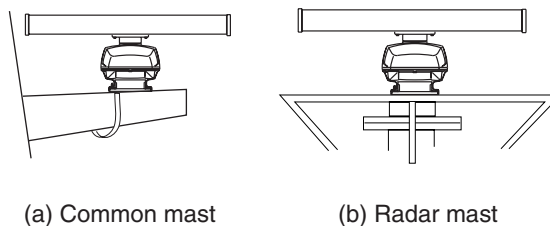

For DRS4A/6A/12A/25A



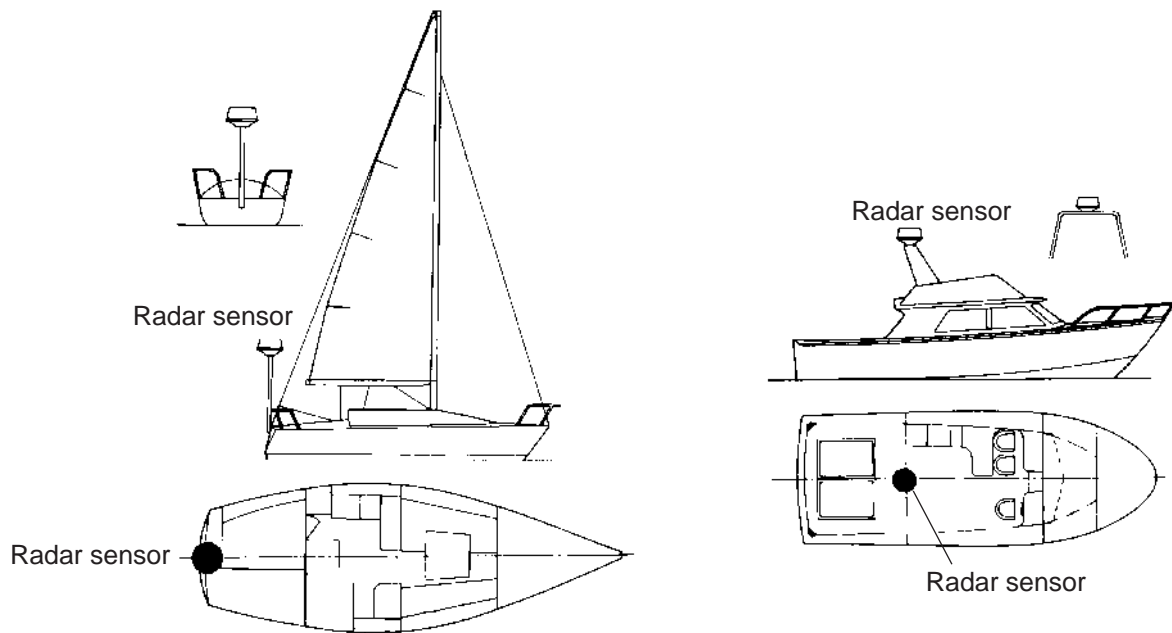

For DRS2D/4D

## 1.2 Mounting Procedure for DRS2D/4D

1. Remove mounting hardware at the bottom of the radar sensor, four each of hex bolts (M10x20), spring washers and flat washers. Save the spring washers and flat washers to use them to fix the radome base to the platform, at step 3. If the thickness of the mounting platform is 5 mm or less, also save the bolts.

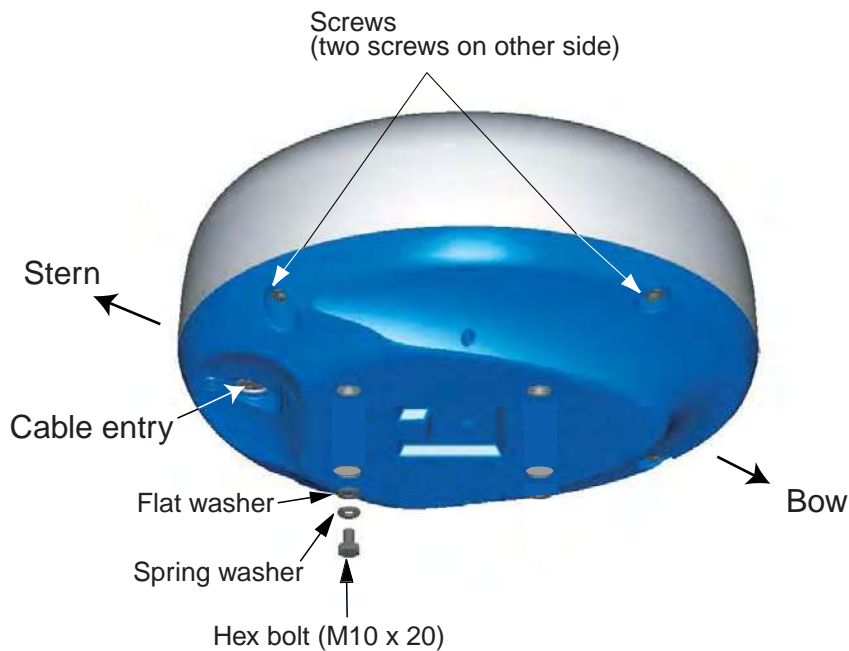

2. Construct a platform (steel or aluminum) 6-10 mm in thickness referring to the outline drawing at the back of this manual. Fasten the platform to the mounting location. Next, position the base so the cable entrance is facing the stern.

**Note:** When drilling holes in the platform, be sure they are parallel with the fore and aft line.

3. Use the hex bolts\*, flat washers and spring washers removed at step 1, and fasten the radome base to the platform. The torque should be between 19.6-24.5N•m.

\*If the thickness of the platform is 6-10 mm, use M10x25 bolts (supplied). For thicker platform, use locally supplied bolts.

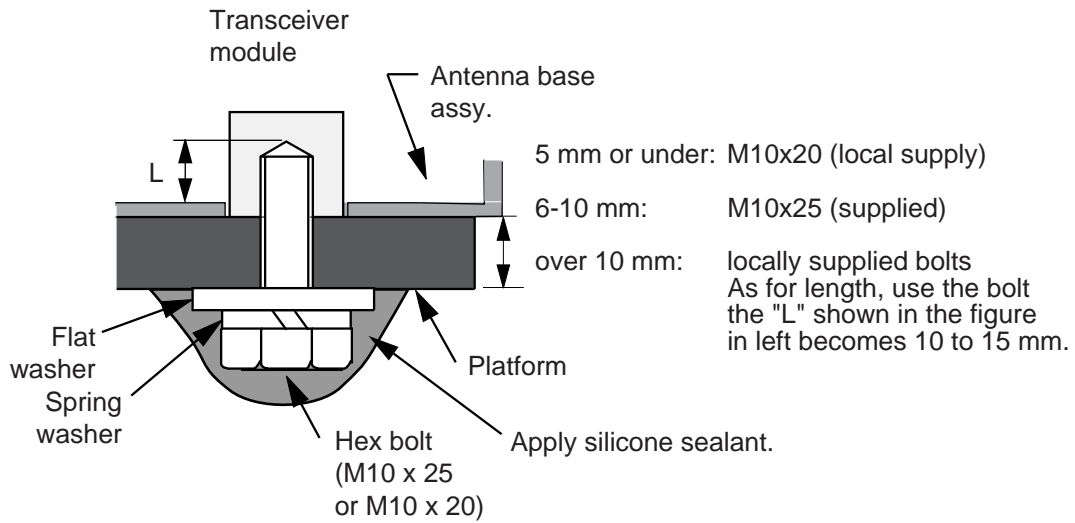

4. Mount the cover tentatively. The cover is opened for wiring at Chapter 2.

## 1.3 Mounting Procedure for DRS4A/6A/12A/25A

Refer to the outline drawing at the back of this manual, and drill five holes in the mounting platform: four holes of 15 mm in diameter for fixing the radar sensor and one hole of 25-30 mm in diameter for the signal cable. The outline drawing shows two cable entrance holes, one on the radar sensor and one on the rubber mat. Use only the one on the rubber mat.

### 1.3.1 Fastening the radiator to the radiator bracket

1. Remove the radiator cap from the radiator bracket.
2. Coat the surface of the radiator bracket with silicone sealant as shown in the figure below.

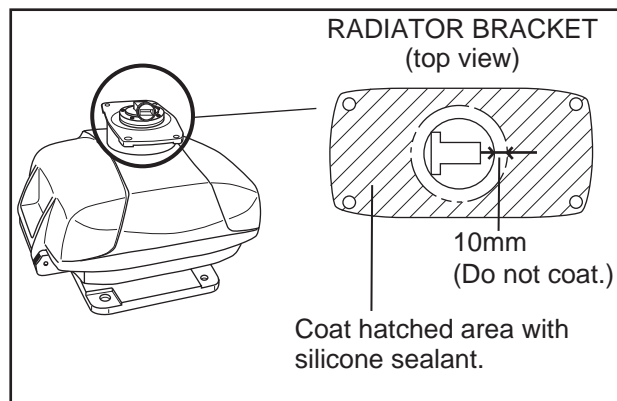

3. Coat threaded holes on the antenna radiator with silicone sealant.
4. Grease the O-ring and set it to the radiator bracket.

- Coat the hex bolts (4 pcs.) with silicone sealant. Fasten the antenna radiator to the radiator bracket with the hex bolts, flat washers and spring washers supplied with the radiator. Then, apply silicone sealant around the junction part between the radiator and bracket.
- Apply silicone sealant to holes to prevent water ingress.

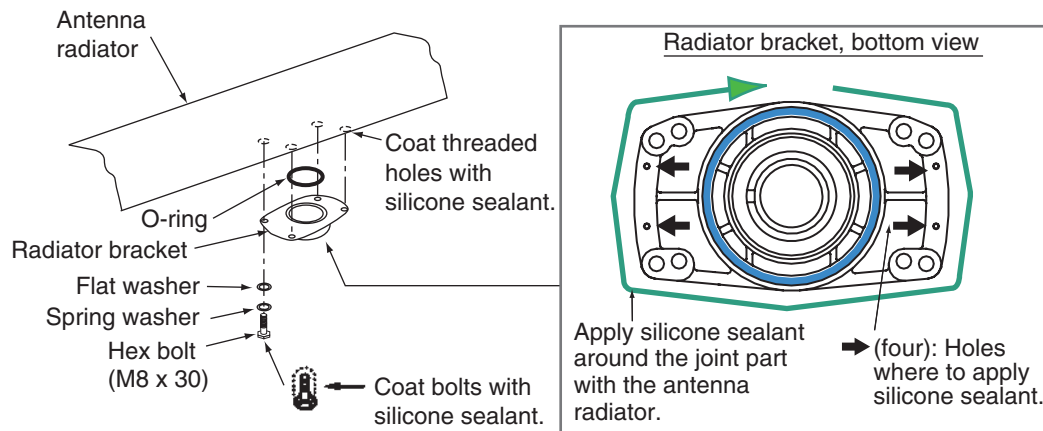

### 1.3.2 Mounting the radar sensor

The radar sensor can be mounted using the fixing holes on the outside (200 x 200 mm) or inside (140 x 150 mm) the radar sensor.

#### Using outside fixing holes of radar sensor

Use the hex bolts (supplied) to mount the radar sensor as below.

- Lay the corrosion-proof rubber mat (supplied) on the mounting platform.

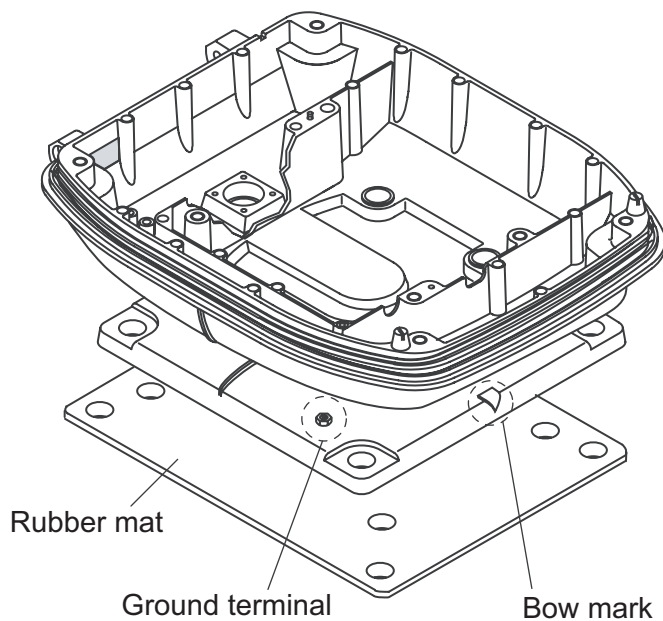

2. Lay the radar sensor on the mounting platform, orienting it as shown below. (The hinges must face toward the stern.)

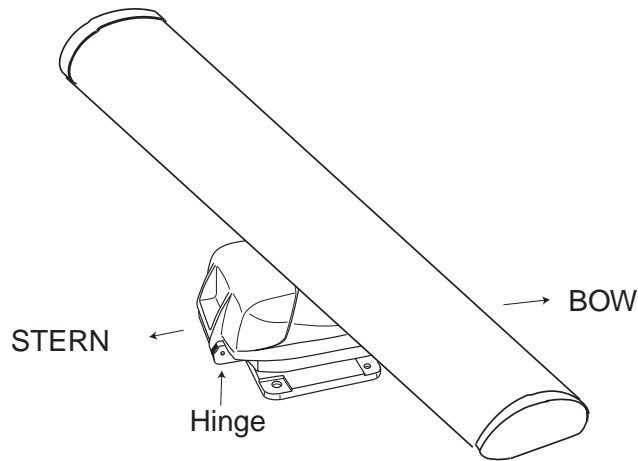

**⚠ CAUTION**

**Do not lift the radar sensor by the radiator; lift it by the housing.**

The radiator may be damaged.

3. Insert four hex bolts (M12 x 60, supplied) and seal washers (φ30, supplied) from the top of the housing, as shown below.

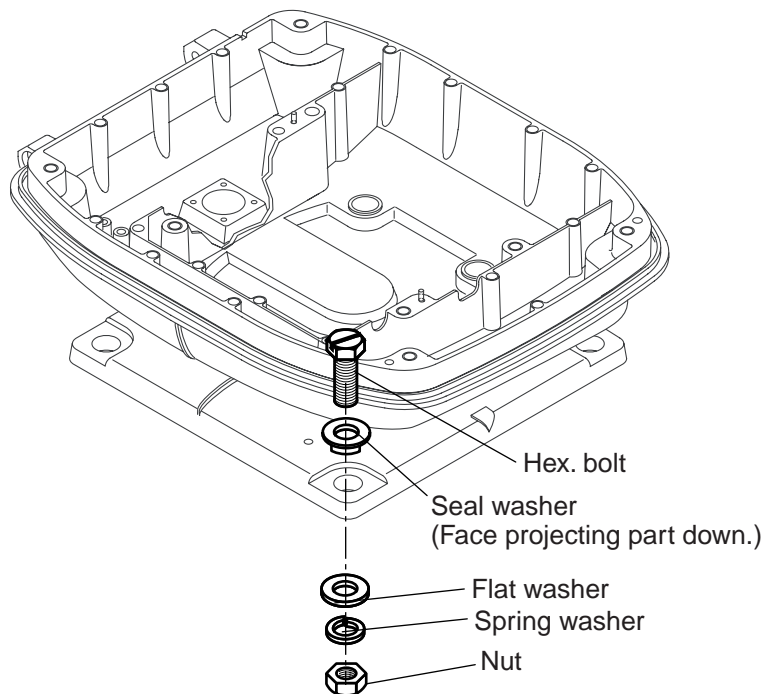

- Pass flat washers (M12, supplied), spring washers (M12, supplied) and nuts (M12, supplied) onto hex. bolts. Fasten by tightening nuts. Do not fasten by tightening the hex. bolts; seal washers may be damaged.

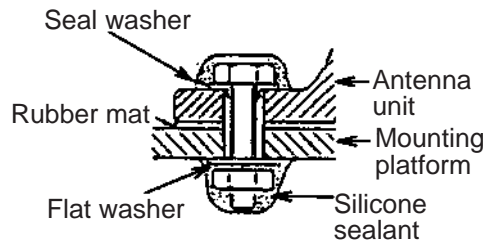

- Coat flat washers, spring washers, nuts and exposed parts of bolts with anticorrosive sealant.
- Prepare ground point in mounting platform (within 300 mm of ground terminal on radar sensor) using M6 x 25 bolt, nut and flat washer (supplied).
- Run the ground wire (RW-4747, 340 mm, supplied) between the ground terminal and ground point.
- Coat ground terminal and ground point with silicone sealant as shown below.

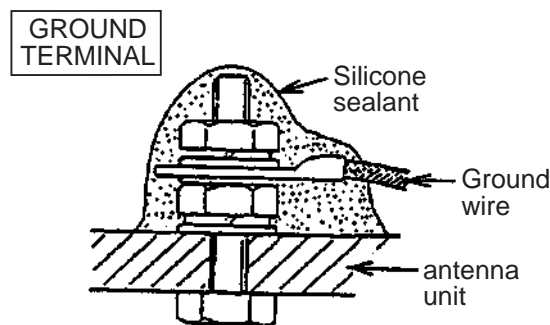
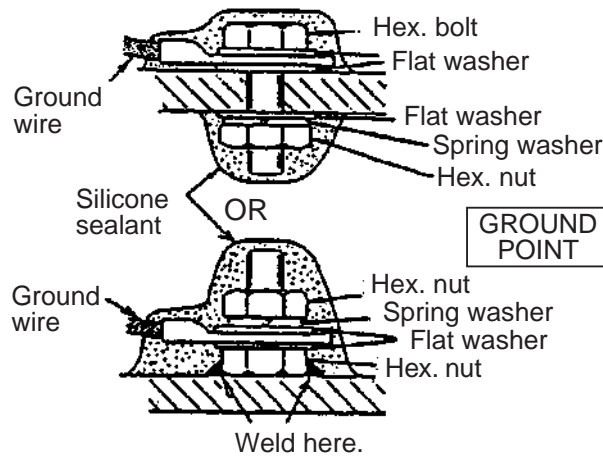

## Using inside fixing holes of the sensor housing

If this radar is replacing a FURUNO radar whose mounting dimensions are the same as this one (140 x 150 mm), it may be possible to use its mounting platform. This method requires removal of the RF unit from the radar sensor to access inside fixing holes. Use hex bolts, flat washers, spring washers and nuts (local supply) to mount the radar sensor.

1. Unfasten four bolts from the cover to open the radar sensor.
2. Unplug the PCS connector from RF unit.
3. Separate upper chassis from lower chassis by removing two bolts (M8x25).
4. Remove RF unit by unfastening two hex bolts and two fixing bolt.

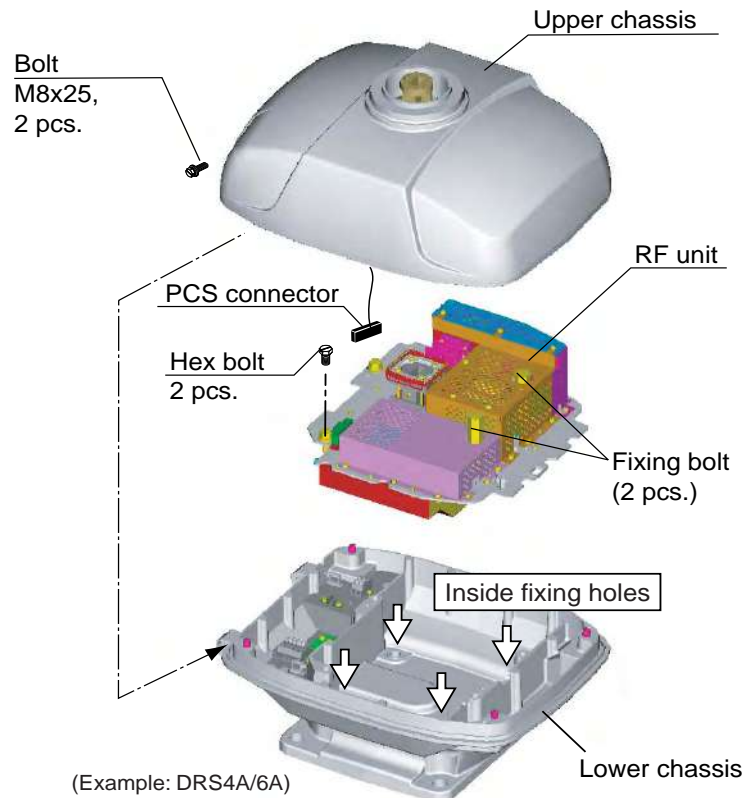

For DRS12A/25A, unfasten four hex bolts, not two fixing bolts, to remove the RF unit.

5. Lay the corrosion-proof rubber mat (supplied) on the mounting platform.
6. Fasten the lower chassis to the mounting platform with hex bolts, spring washers, flat washers and nuts (local supply), and then coat flat washers, nuts and exposed parts of bolts with silicone sealant. Cut a slit in the rubber bushing and insert bolt into the bushing. Do not use seal washers.
7. Remount RF unit.
8. Coat outside fixing holes with silicone sealant and then attach caps (supplied) to holes.
9. Do steps 6-8 on page 6.

## 1.4 Mounting of Power Supply Unit

### 1.4.1 PSU-013 (for DRS25A)/PSU-012 (Option)

For combinations shown below, the optional power supply unit PSU-012 or PSU-017 is necessary. The PSU-013 is required for any DRS25A installation

	DRS2D/4D	DRS4A	DRS6A	DRS12A
MFD8	NO	<b>PSU-012</b>	<b>PSU-012</b>	<b>PSU-012</b>
MFD12	NO	NO	NO	<b>PSU-012</b>
MFDBB	NO	NO	NO	NO
TZT9	<b>PSU-012 or PSU-017*</b>	<b>PSU-012</b>	<b>PSU-012</b>	<b>PSU-012</b>
TZT14	<b>PSU-012 or PSU-017*</b>	<b>PSU-012</b>	<b>PSU-012</b>	<b>PSU-012</b>
TZTBB	<b>PSU-012 or PSU-017*</b>	<b>PSU-012</b>	<b>PSU-012</b>	<b>PSU-012</b>

\*: The PSU-017 is available in the combination of DRS2D/4D and TZT9/14/BB. See section 1.4.2.

#### Contents of PSU-012/013

Name	Type	Code No.	Qty	Remarks
Power supply unit	PSU-012	-	1	
	PSU-013	-		For DRS25A
Cable assy	VL3P-VV-S2X2C-AA050	000-152-217-11	1	5 m
LAN cable	MOD-Z072-050+	000-167-176-10	1	5 m, standard
Self-tapping screw	4x20, SUS304	000-158-850-10	4	
Fuse*	FGB0 250V 10A	000-155-839-10	2	For 24 VDC
	FGB0 250V 15A	000-157-874-10	2	For 12 VDC
XH Connector Assembly	03-2345(2P)	001-183-760-00	1	For TZT9/14/BB

\*: The power supply unit is shipped with 15A fuse. Replace fuse with 10A when using the unit with 24V ship's battery.

## **Mounting**

When selecting a location, keep in mind the following points. Fix the power supply unit on the desktop or bulkhead with four self-tapping screws (4x20, supplied).

- Location is dry, well ventilated.
- Make sufficient maintenance space.
- Installed within 2, 5 or 10 m (2 and 10 m: optional supply) from the multi function display.

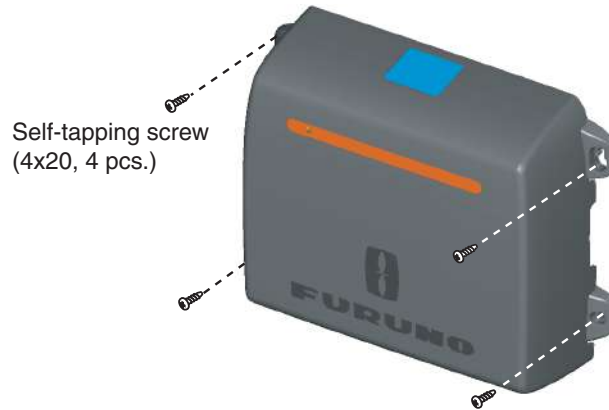

**Note:** When you install the unit on the bulkhead, fix the unit with the following direction.

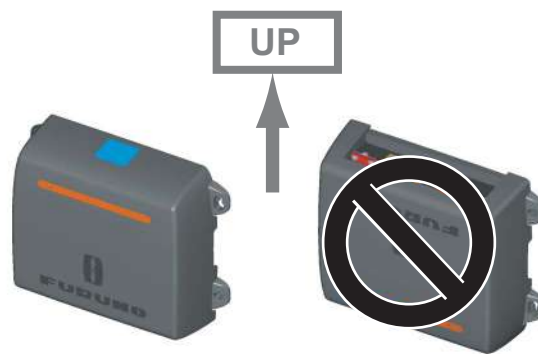



## 1.4.2 PSU-017 (option)

A power supply unit is required when you connect a radar sensor. The PSU-017 is available in the combination of DRS2D/4D and TZT9/14/BB. Use the PSU-012 or PSU-013 in all other combinations.

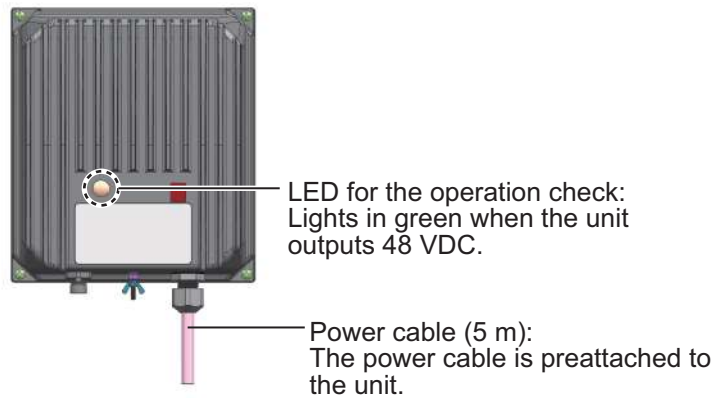

**Note:** When the fuse in this unit blows, the LED does not light. At this time, the PSU-017 can not output 48 VDC, but high voltage is still present inside. Turn off the unit from the ship's mains to service the unit.

### Contents of PSU-017

Name	Type	Code No.	Qty	Remarks
Power supply unit	PSU-017	-	1	
Self-tapping screw	4x20, SUS304	000-158-850-10	4	
Fuse	FGMB 125V 7A PBF	000-157-493-10	1	For the replacement
	FGMB 125V 1.5A PBF	000-157-464-10	1	

### Mounting

When selecting a location, keep in mind the following points. Fix the power supply unit on the desktop or bulkhead with four tapping screws (4x20, supplied).

- Location is dry, well ventilated.
- Make sufficient maintenance space.
- A disconnecting device (breaker, etc.) is required when the power cable is connected to ship's mains.

## 2. WIRING

The MFDBB, MFD8, MFD12, PSU-012 or PSU-017 connects to the radar sensor with the two-way cable MOD-ASW0001 (MOD-ASW0002 for DRS25A). In order to minimize the chance of picking up electrical interference, avoid where possible routing the two-way cable near other onboard electrical equipment. After passing the cable through the hole in the radar sensor, apply sealing compound around the hole for waterproofing. When connecting to other NMEA2000 equipment, use the optional cable M12-05BFFM ( $\phi 6$ ) or CB-05BFFM ( $\phi 10$ ).

**Note:** When TZZ9/14/BB is connected to the radar sensor, confirm that the program version of the radar sensor is 0359235-01.16 or higher.

### NOTICE

**Before connecting or disconnecting the NMEA2000 cable, turn off the radar sensor.**

The sensor may become damaged if the power is not turned off.

#### Wiring for DRS2D/4D/4A/6A/12A without PSU-012

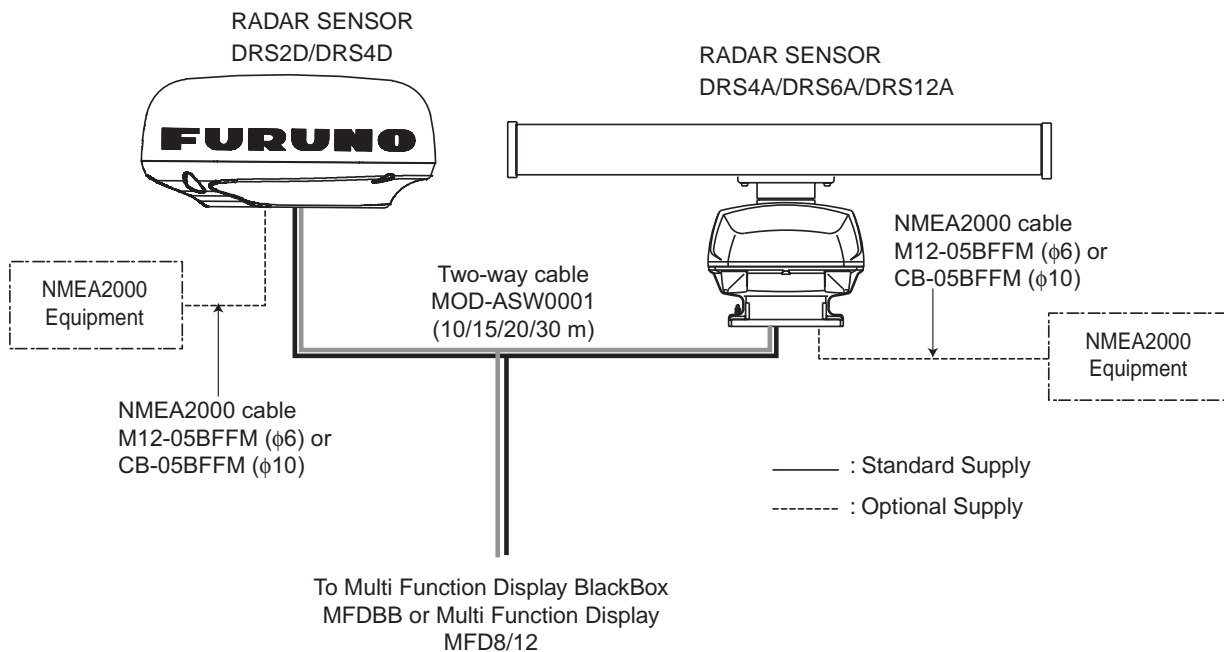

## Wiring for DRS2D/4D/4A/6A/12A with PSU-012

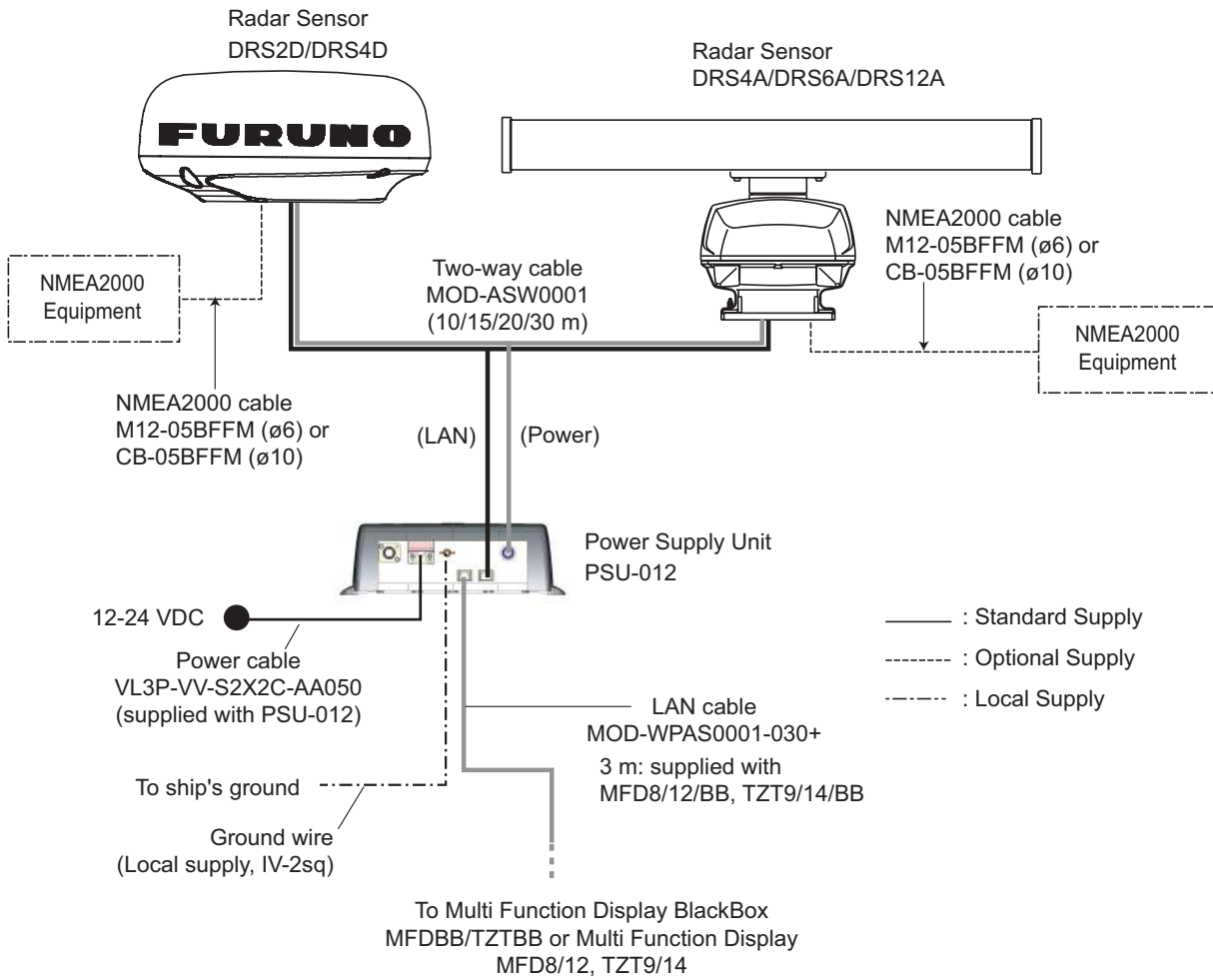

## Wiring for DRS2D/4D with PSU-017

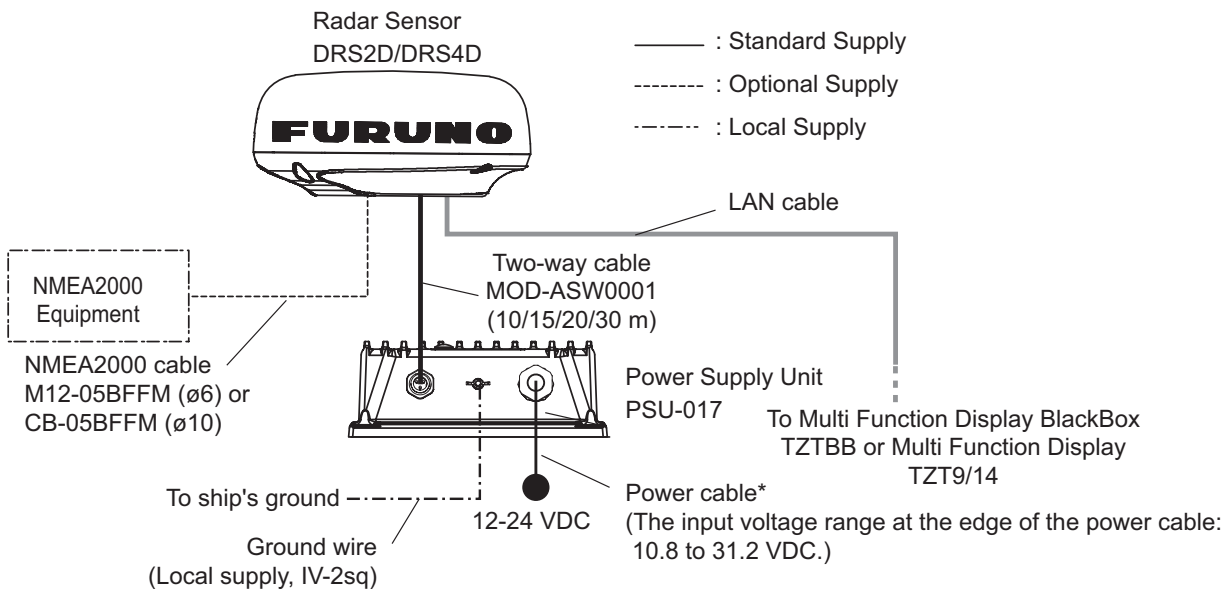

\*: The power cable is supplied with attached to the unit. When connecting the power cable to ship's mains, pass through the disconnecting device (breaker, etc.).

## Wiring for DRS25A

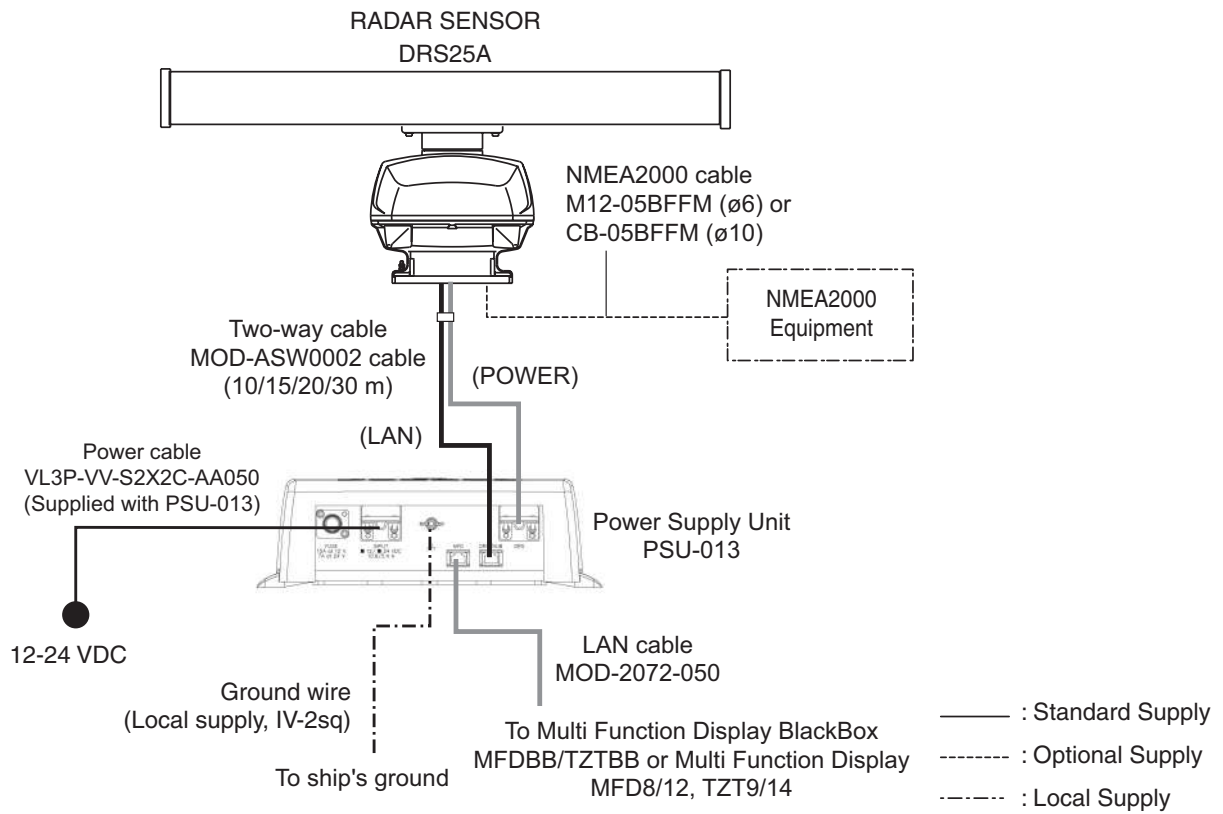

## How to terminate of NMEA2000 connection

When connecting the radar sensor and an NMEA2000 equipment using the optional cable M12-05BFFM ( $\phi 6$ ) or CB-05BFFM ( $\phi 10$ ), attach the terminator (supplied as installation materials) to the NMEA connector in the radar sensor.

1. Twist the lead wire of the resistor assembly to the cable M12-05BFFM ( $\phi 6$ ) or CB-05BFFM ( $\phi 10$ ), and solder them as below.

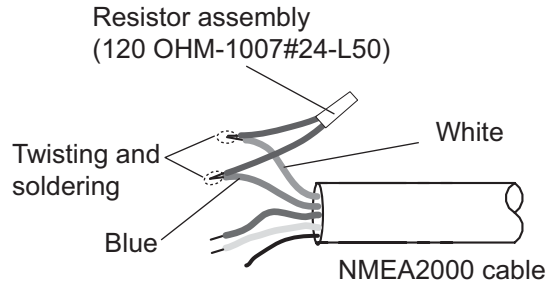

2. Connect wires to the NMEA connector consulting the label on the connector.

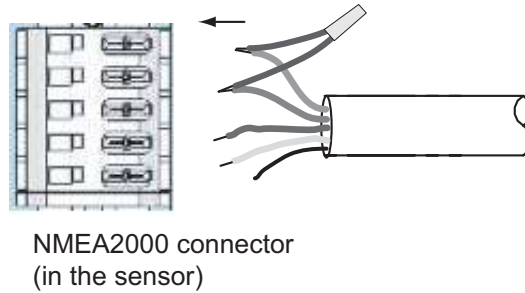

**Note:** This fabrication is not necessary when the external terminators are attached as below.

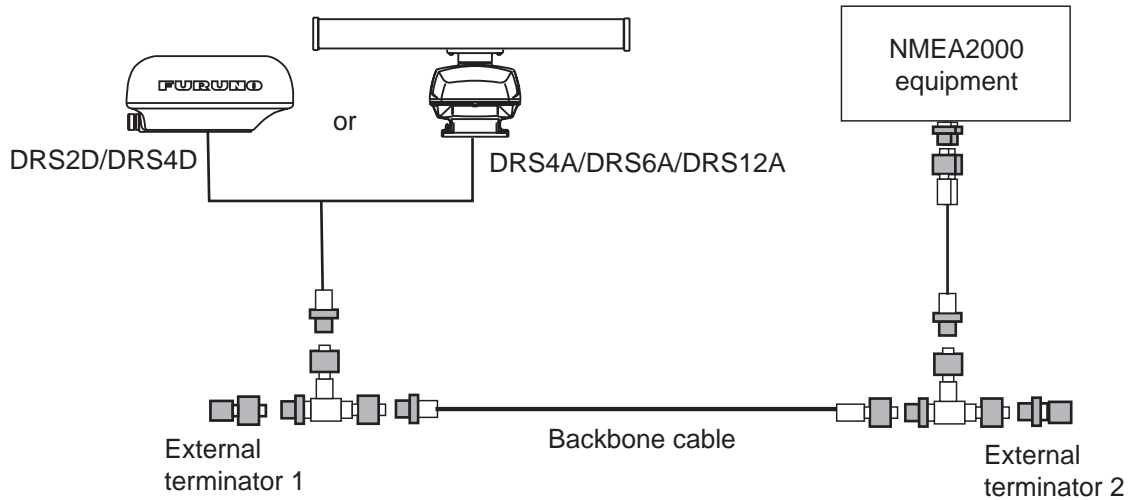

## 2.1 Wiring inside DRS2D/4D

### Two-way cable connection

1. Unfasten three screws at the bottom of the mounting base to remove the fixing plate for the gasket.

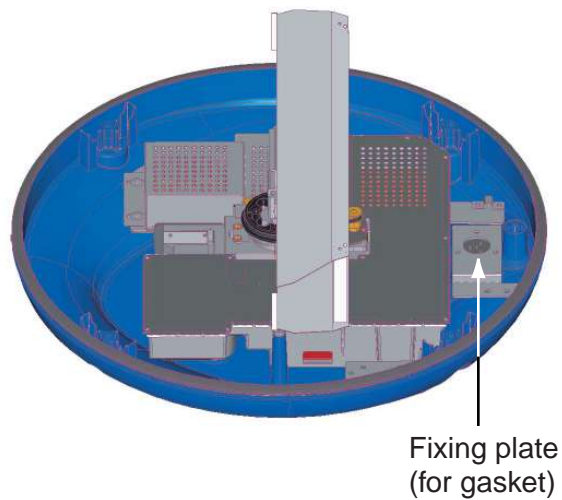

2. Remove the gasket, and pass the two-way cable MOD-ASW0001.
3. Fasten the shield of the cable (power) with the cable clamp in the radar sensor, and connect the connector of cable (power) to the power terminal.
4. Connect the RJ-45 connector of the cable (LAN) to the LAN terminal in the radar sensor.

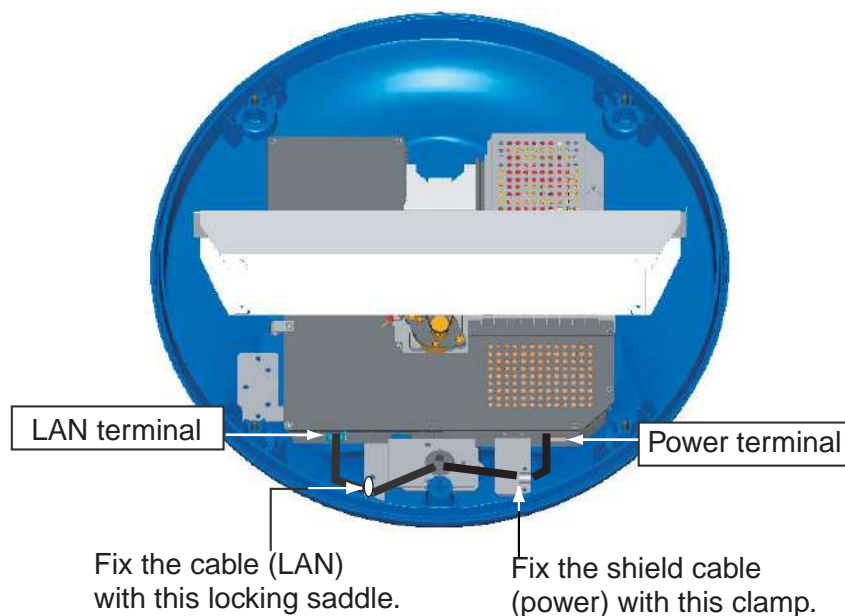

5. Push cables of the two-way cable into the slits of the gasket inside the radar sensor.

**Note:** The ends of the gasket are different. Larger end should be up.



- Slide the gasket on cables so that the amount of cable above the gasket is lower than the RF chassis.

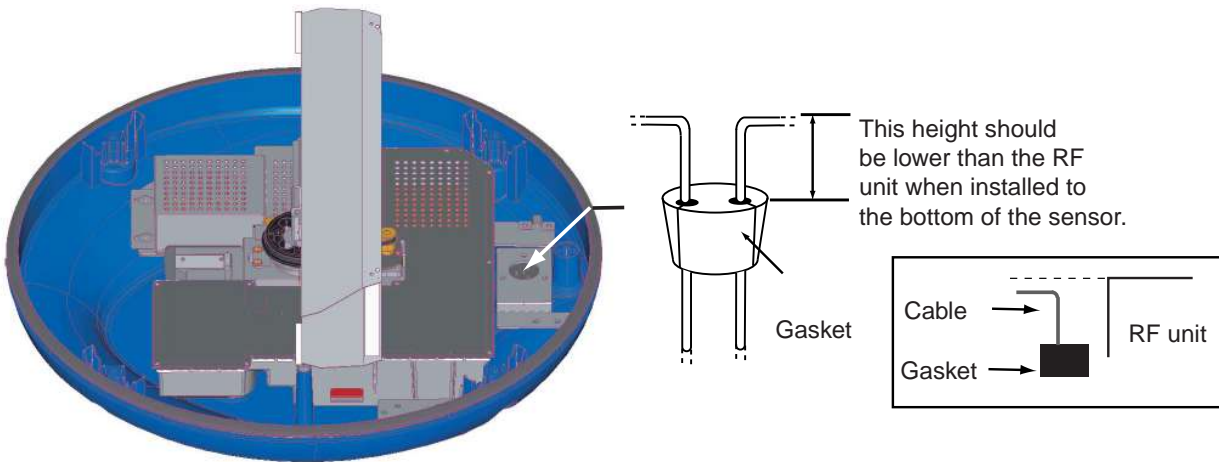

**Note:** If the two-way cable touches the platform near the mounting base, wind vinyl tape around the cable at the point where it is bent.

- Confirm that the rubber gasket is properly positioned and that the triangle mark on the cover is aligned with the triangle mark on the mounting base, then tighten the fixing screws for the cover.

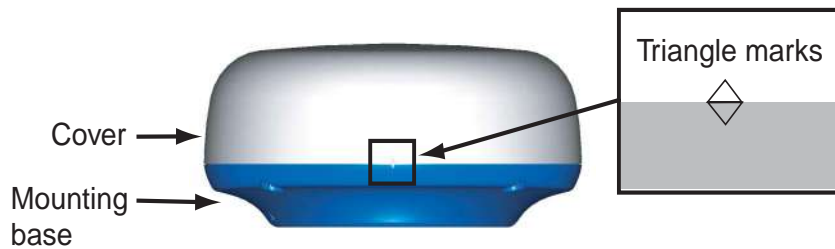

### **Connecting to NMEA2000 equipment**

To connect NMEA2000 equipment to the sensor, wire an optional NMEA2000 cable, M12-05BFFM ( $\phi 6$ ) or CB-05BFFM ( $\phi 10$ ), as shown below. Also, the gasket at the bottom of mounting base must be replaced.

- Do steps 1 to 4 on the previous page.
- Refer to the figure below, and fabricate the cable M12-05BFFM ( $\phi 6$ ) or CB-05BFFM ( $\phi 10$ ).

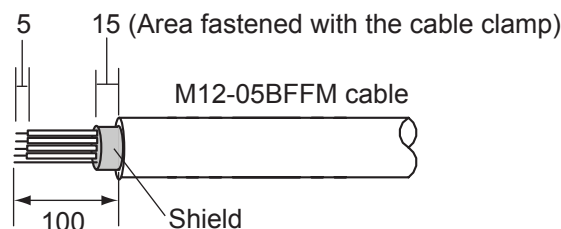

Fabrication of cable M12-05BFFM ( $\phi 6$ )

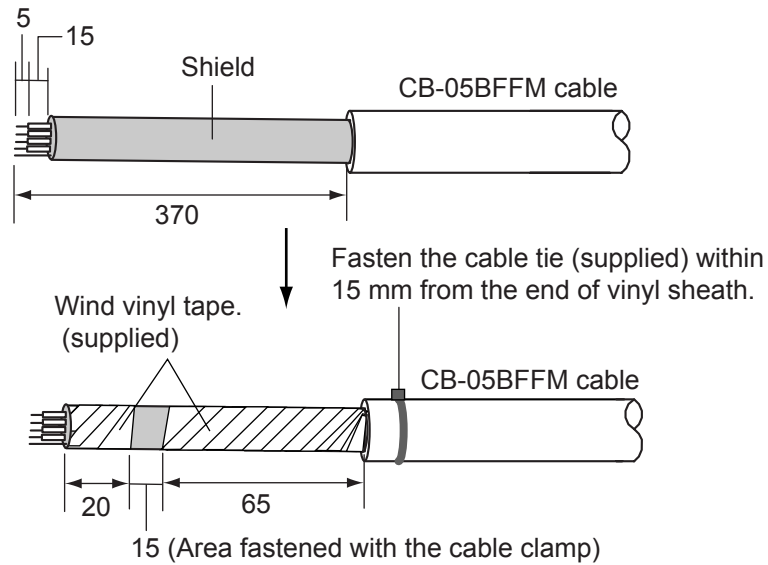

Fabrication of CB-05BFFM cable

3. Insert wires of cable M12-05BFFM ( $\phi 6$ ) or CB-05BFFM ( $\phi 10$ ) to the NMEA connector inside the radar sensor, consulting the label on the connector for location. As for shield, use the cable clamp shown below.

Cable	M12-05BFFM ( $\phi 6$ )	CB-05BFFM ( $\phi 10$ )
Clamp	Use the clamp pre-attached inside the radar sensor.	Use the clamp supplied with the optional gasket (Type: OP03-203, Code No.: 001-025-290)

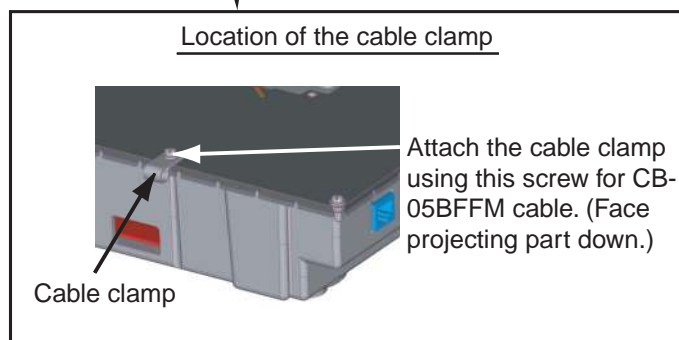
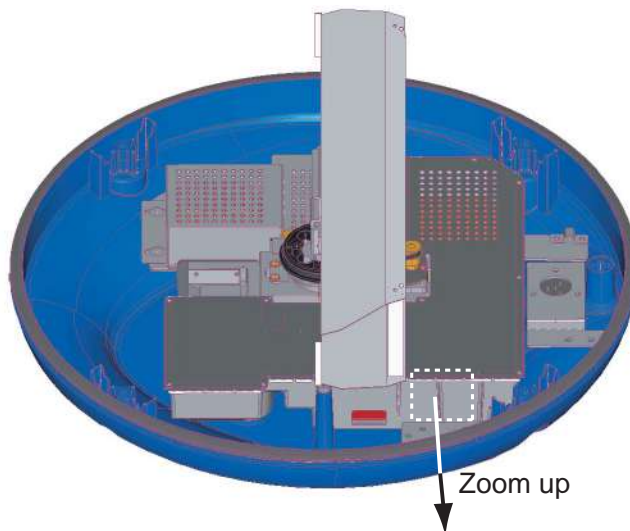



4. Push LAN and POWER cables of the two-way cable and cable M12-05BFFM ( $\phi 6$ ) or CB-05BFFM ( $\phi 10$ ) into the slits of the gasket inside the mounting base. Depending on the NMEA2000 cable used, replace the gasket as shown below.

Cable type	M12-05BFFM ( $\phi 6$ )	CB-05BFFM ( $\phi 10$ )
Gasket	Use the gasket supplied in the plastic bag inside the radar sensor.	Use the optional gasket. (Type: OP03-203, Code No.: 001-025-290)

**Note:** The ends of the gasket are different. Larger end should be up)



5. Slide the gasket on cables so that the amount of cable above the gasket is lower than the RF chassis.

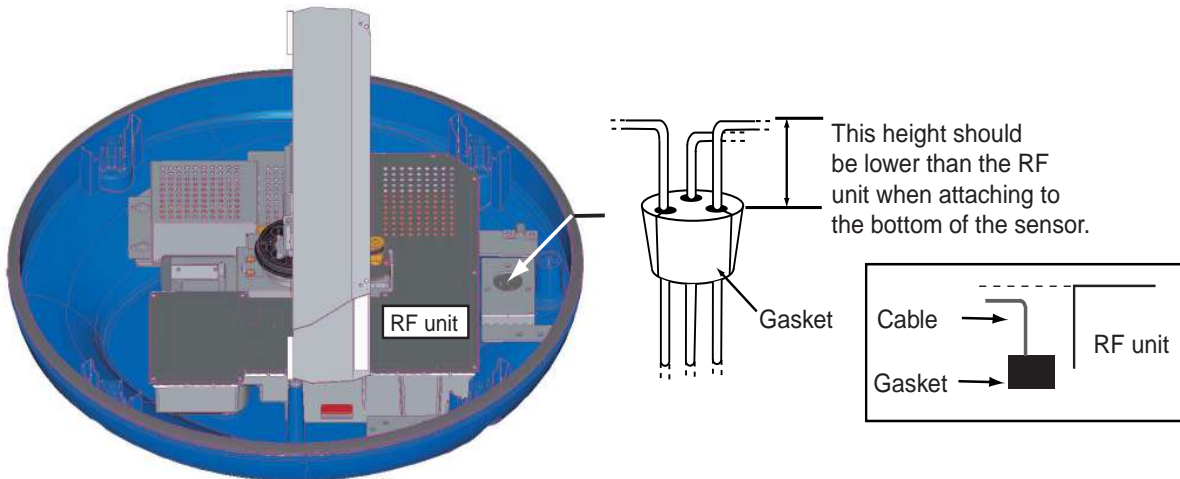

**Note:** If the two-way cable touches the platform near the radar sensor base, wind vinyl tape around the cable at the point where is bent.

6. Confirm that the rubber gasket is properly positioned and that the triangle mark on the cover is aligned with the triangle mark on the mounting base, then tighten the fixing screws for the cover.

## 2.2 Wiring inside DRS4A/6A/12A/25A

### Two-way cable connection

If you have no NMEA2000 equipment to connect, use the MOD-ASW0001 cable (standard supply).

1. Open the radar sensor cover by loosening four bolts, and fix the stay for safety purpose.
2. Unfasten four bolts to detach the plate, gasket, washer and lid. Discard the lid at the bottom of the hole for the gasket.

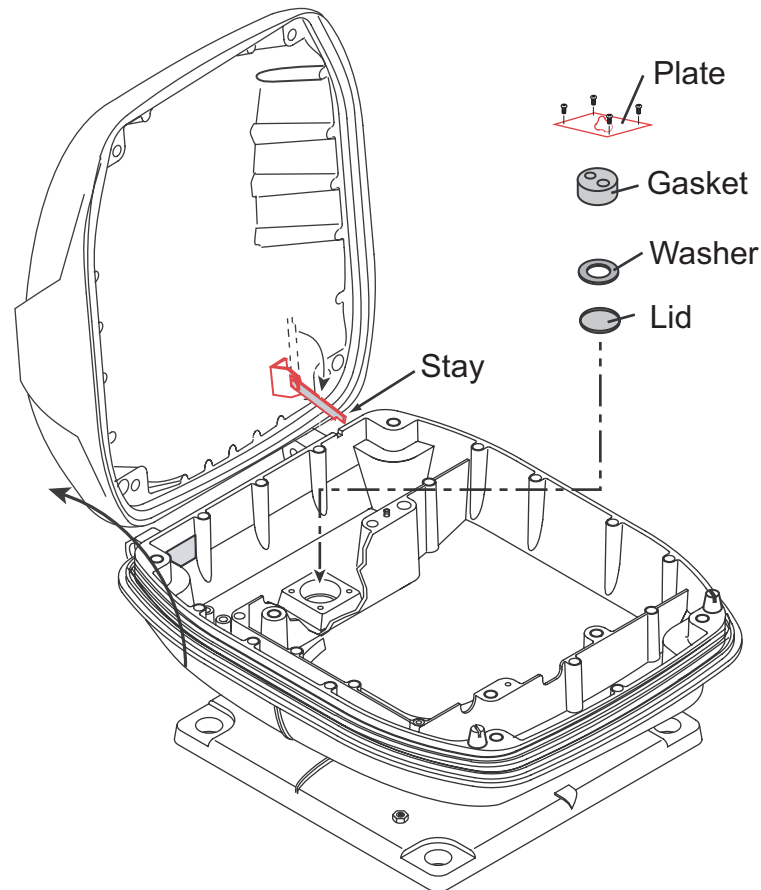

3. Pass the two-way cable MOD-ASW0001 (MOD-ASW0002 for DRS25A) through the bottom of the chassis and washer.
4. Fasten the shield of the power cable of the two-way cable (part of the foil) with the cable clamp in the radar sensor, and then connect the power cable to the power terminal as shown on next page.

5. Attach the LAN cable of the two-way cable to the LAN terminal in the radar sensor.

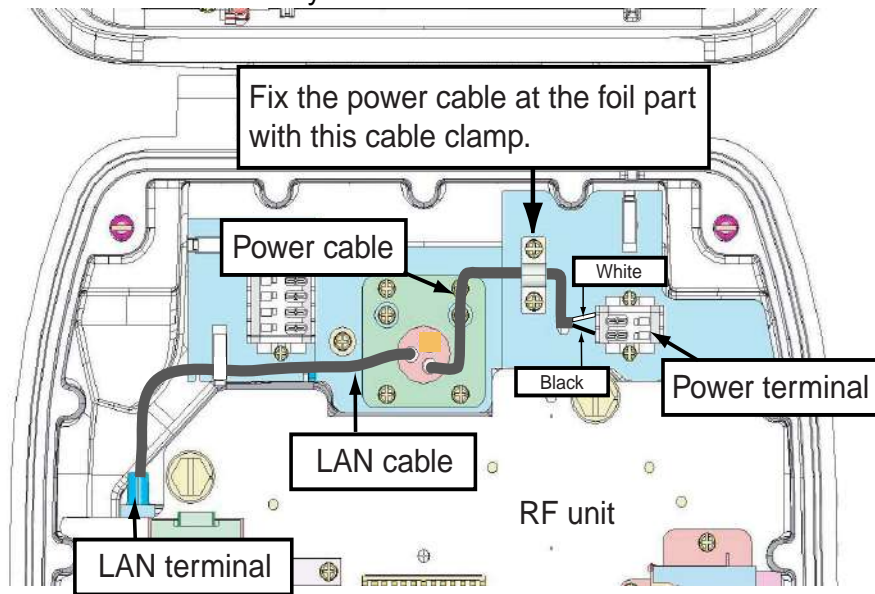

DRS4A/6A/12A

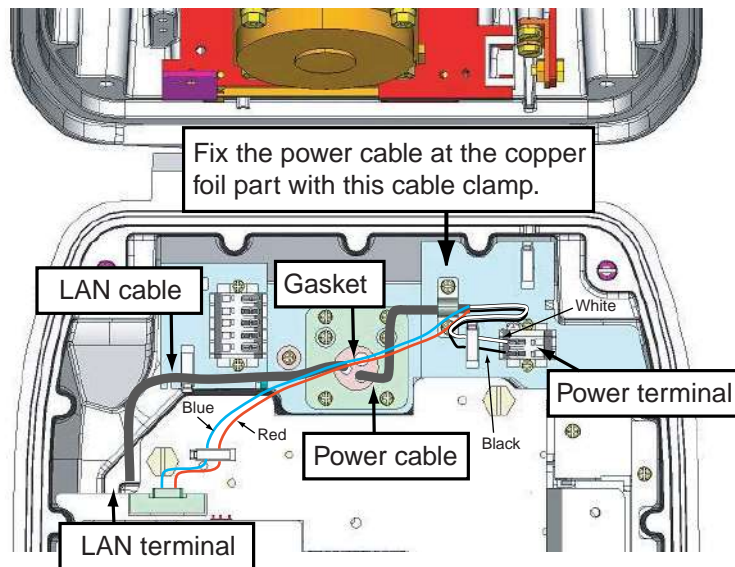

DRS25A

6. Refer to the illustration shown below, and attach the gasket to the two-way cable, inserting the cable into the slits on the gasket.

- Slide the gasket on cables so that the amount of cable above the gasket is lower than the RF chassis.

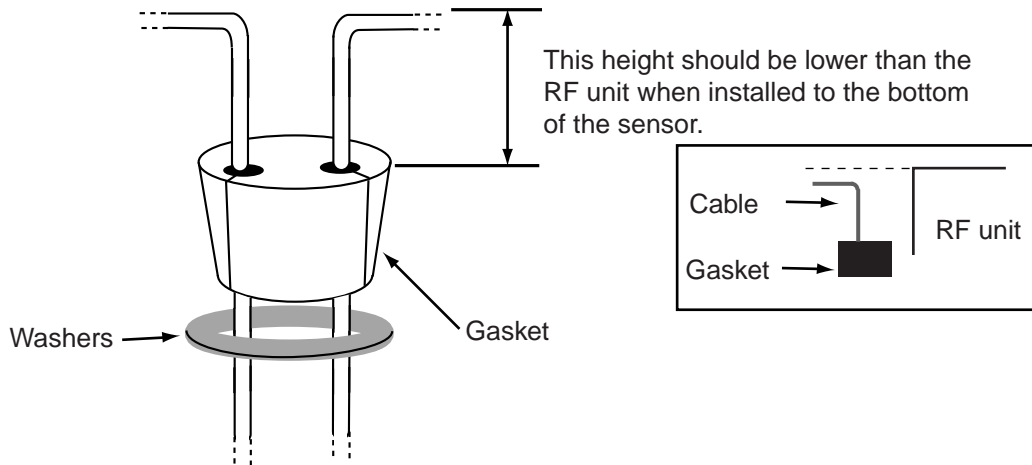

- Push the gasket and washers into the hole at the bottom of the radar sensor, then fasten four pan head screws to fix the plate to the sensor.
- Release the stay and close the cover.

**Note:** When closing the cover, set the gaskets to grooves in the bottom chassis, then tighten bolts.

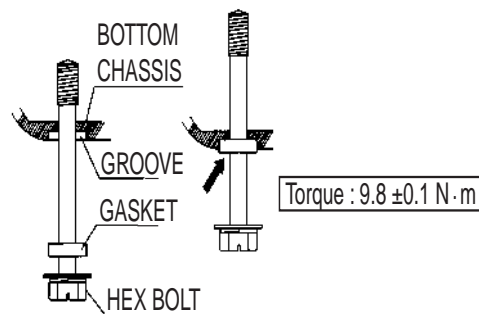

### **Connecting to NMEA2000 equipment**

To connect NMEA2000 equipment to the sensor, use an optional NMEA2000 cable, M12-05BFFM (φ6) or CB-05BFFM (φ10). Also, the gasket at the bottom of the antenna sensor must be replaced.

- Do steps 1 to 5 on pages 19 and 20.
- Fabricate the cable M12-05BFFM (φ6) or CB-05BFFM (φ10) as shown below.

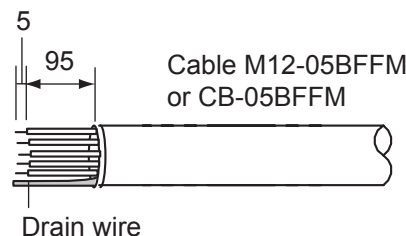

- Pass the cable through the bottom of the chassis.
- Insert wires of the cable M12-05BFFM (φ6) or CB-05BFFM (φ10) to the NMEA connector inside the radar sensor, consulting the label on the connector for location. As for drain wire, attach

the crimp-on lug (pre-attached at the bottom of the chassis) to the drain wire, and fasten it with the screw shown below.

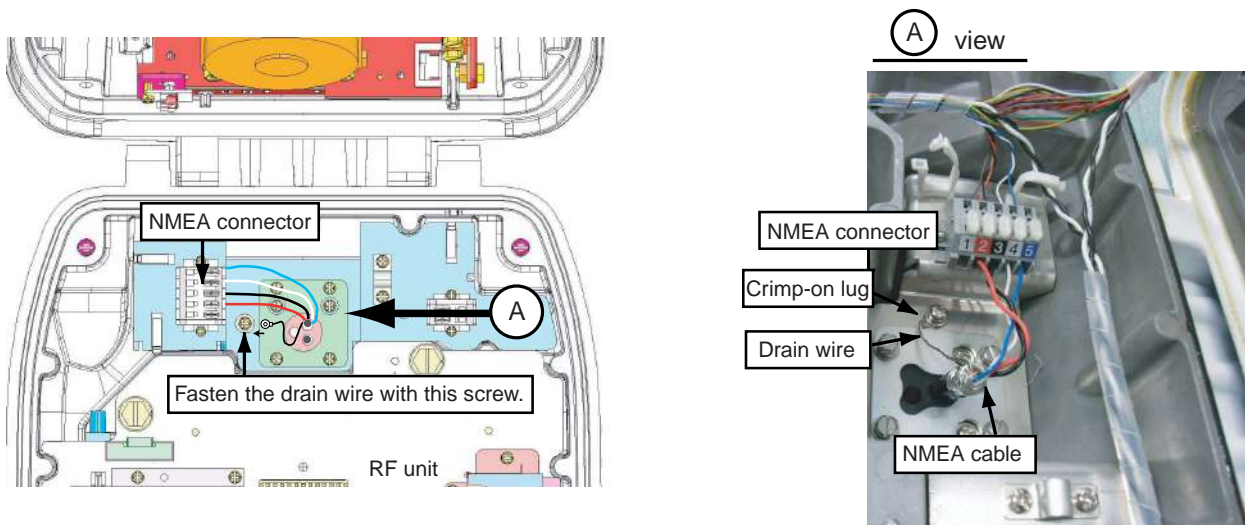

5. Depending on the NMEA2000 used, replace the gasket as shown below.

**DRS4A/6A/12A**

Cable type	M12-05BFFM (φ6)	CB-05BFFM (φ10)
Gasket	Use the gasket supplied in the plastic bag inside the radar sensor.	Use the optional gasket. (Type: OP03-205, Code No.: 001-025-790)

**DRS25A**

Cable type	M12-05BFFM (φ6)	CB-05BFFM (φ10)
Gasket	Use the gasket supplied in the plastic bag inside the radar sensor.	Use the optional gasket. (Type: OP03-206, Code No.: 001-035-290)

- Refer to the illustration shown on next page, and attach the gasket to the two-way cable inserting the cable into the slits on the gasket.
- Slide the gasket on cables so that the amount of cable above the gasket is lower than the RF chassis.

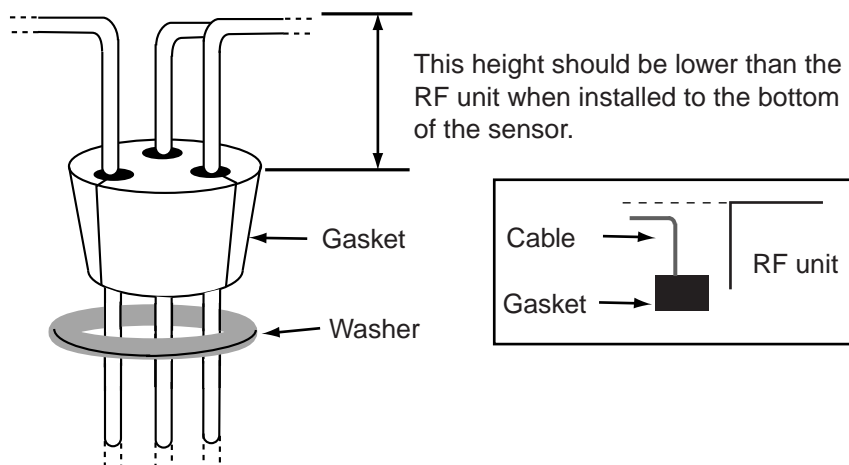

8. Do steps 8 and 9 on the previous page.

## 2.3 Wiring of Power Supply Unit

### 2.3.1 Wiring inside power supply unit PSU-013 (for DRS25A)

1. Detach the body cover by hand.
2. Loosen six pan head screws (M3x8) and slide the shield cover upward to remove it.
3. Unfasten four pan head screws (M14x10) to remove two cable clamps.

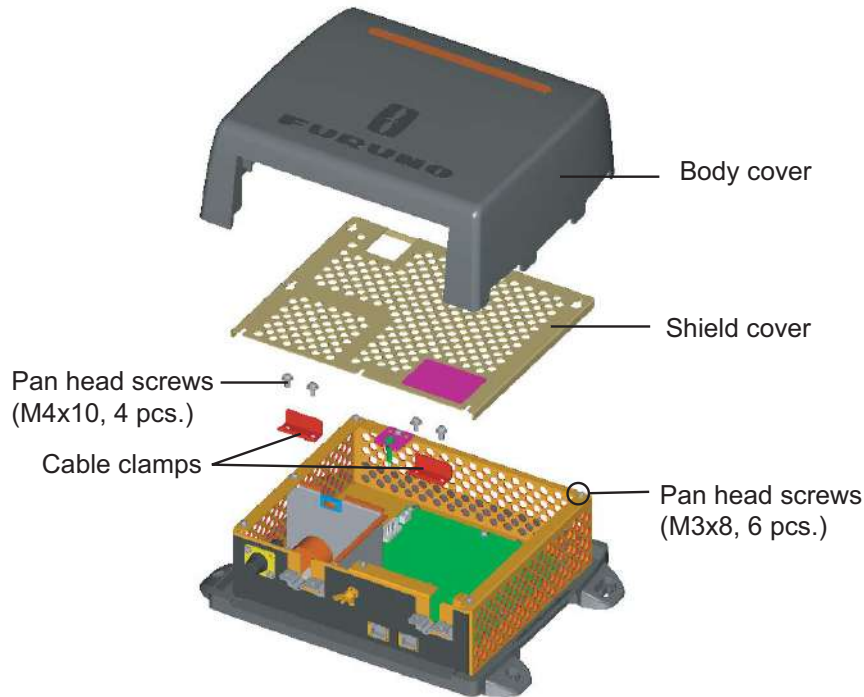

4. Connect the VL3P-VV-S2X2C-AA050 and MOD-ASW0002 cables (supplied) to appropriate connectors in the power supply unit as shown below.

**Note:** When the power supply unit is connected to TZT9/14/BB, attach the XH Connector Assembly (supplied with PSU-013) to J7 on the PWR board. For details, see "How to connect TZT9/14/BB" (supplied with PSU-013).

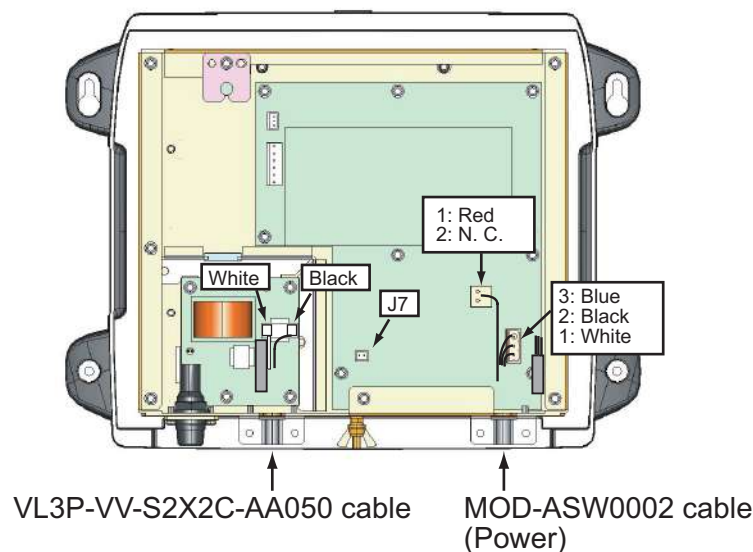

5. Remove two cable clamps, shield cover and body cover in that order.
6. Connect other cables.

## 2.3.2 Wiring inside power supply unit PSU-012 (Option)

1. Detach the body cover by hand.
2. Loosen six pan head screws (M3x8) and slide the shield cover upward to remove it.
3. Unfasten two pan head screws (M4x12) to remove the cable clamp.

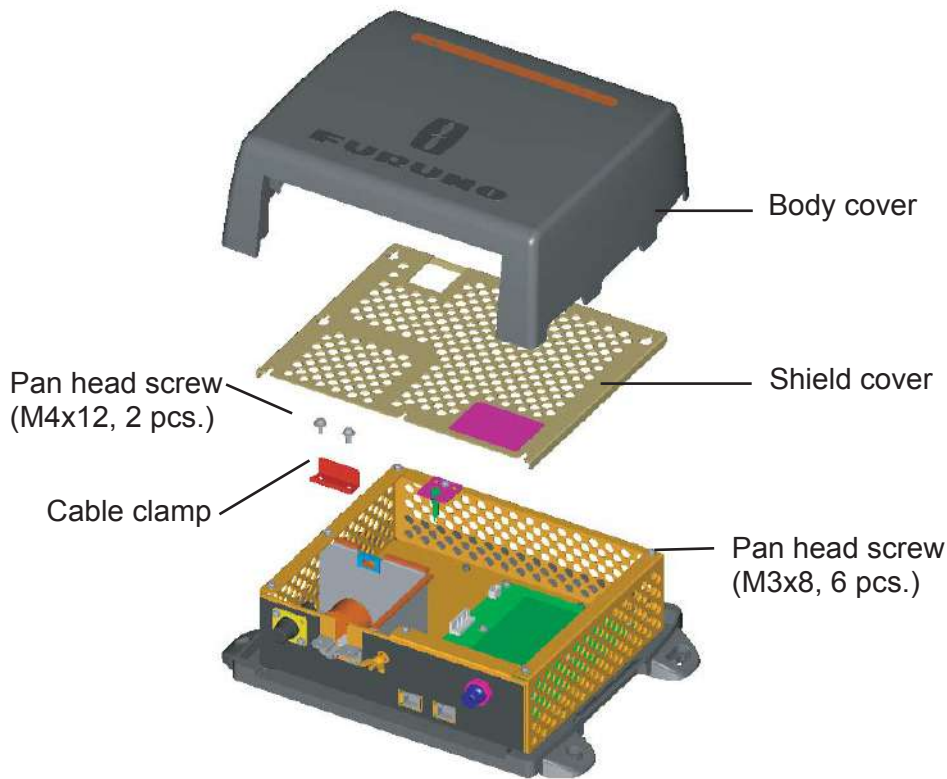

4. Connect the cable VL3P-VV-S2X2C-AA050 (supplied) to the power connector in the PSU-012.

**Note:** When the power supply unit is connected to TZT9/14/BB, attach the XH Connector Assembly (supplied with PSU-012) to J7 on the PWR board. For details, see "How to connect TZT9/14/BB" (supplied with PSU-012).

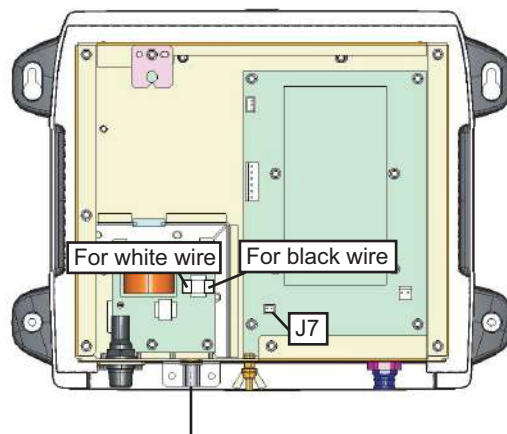

Put the cable VL3P-VV-S2X2C-AA050 here at the shield part.

5. Remount the cable clamp, shield cover and body cover in that order.
6. Connect other cables.

### 2.3.3 Wiring the power supply unit PSU-017 (option, for DRS2D/4D)

Connect the power cable and MOD-ASW0001 cables to appropriate connectors of the power supply unit as shown below. When you connect the power cable to ship's mains, pass through the disconnecting device (breaker, etc.).

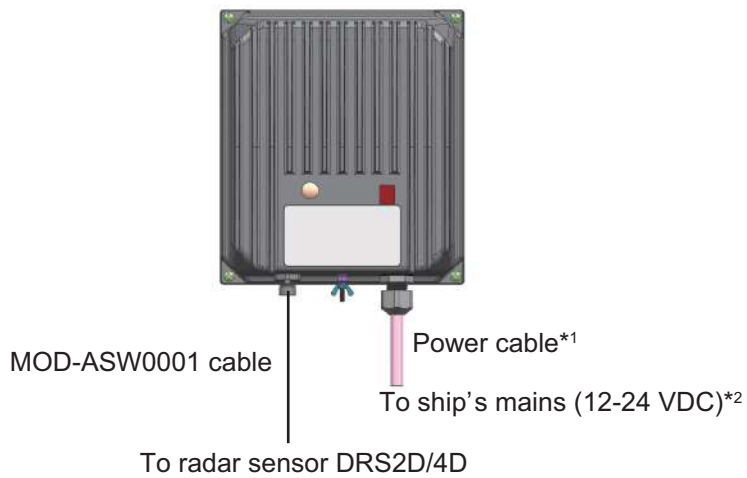

\*1: Input voltage range at the edge of the power cable: 10.8 to 31.2 VDC.

\*2: Be sure to pass through a disconnecting device (breaker, etc.).

#### **Replacement of the fuse**

1. Remove four self-tapping screws (4x20) to dismount the unit.
2. Remove four screws (M3x8) at the back of the unit to remove the base.

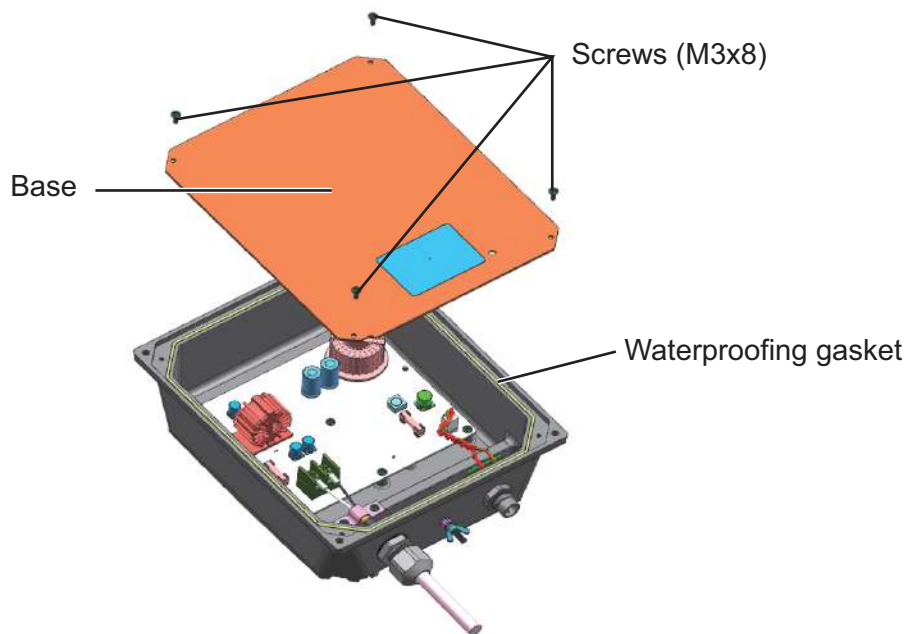



3. Confirm that the LED on the board is OFF, and then replace the fuse.

**Note:** DO NOT change the fuse if the LED is ON; this indicates high voltage is present.

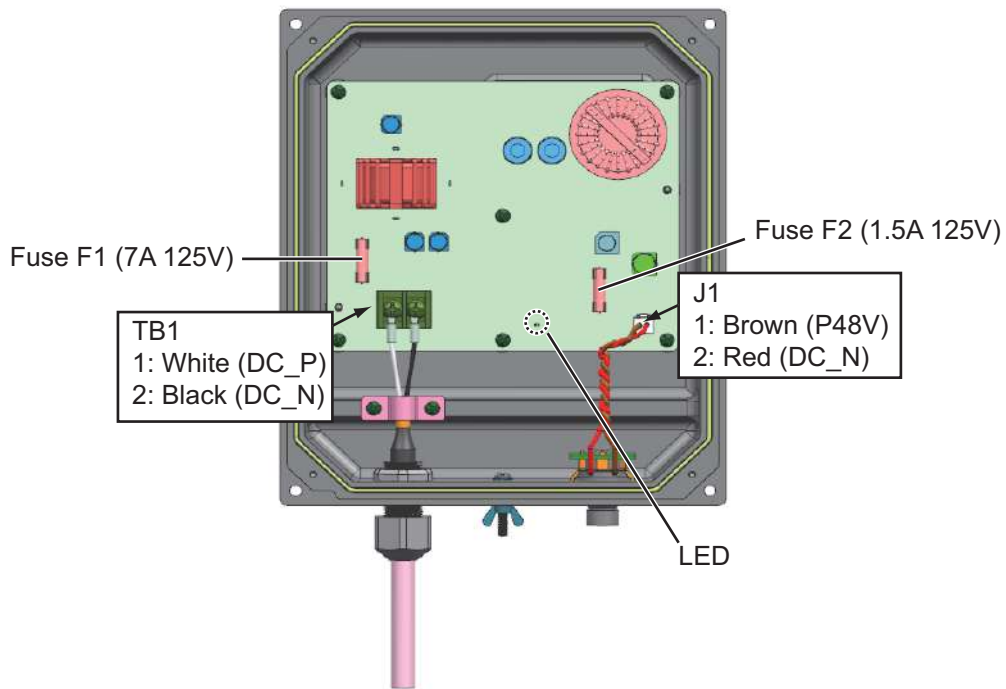

4. Reattach the base and install the unit.

**Note:** Before fixing the base, make sure the waterproofing gasket is correctly seated in the groove in the chassis.

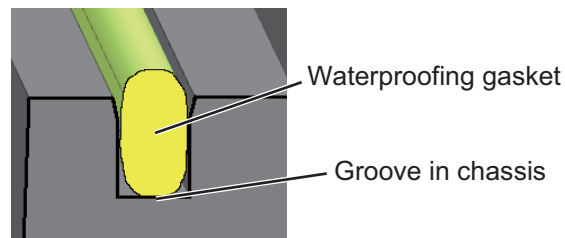

**SPECIFICATIONS OF RADAR SENSOR  
DRS SERIES**

**1 RADIATOR**

- 1.1 Antenna type
  - DRS2D/4D Patched waveguide array antenna
  - DRS4A/6A/12A/25A Slotted waveguide array antenna
- 1.2 Antenna length
  - DRS2D 19-inch
  - DRS4D 24-inch
  - DRS4A 3.4 ft
  - DRS6A 4 ft
  - DRS12A/25A 4 ft (XN12A), 6 ft (XN13A)
- 1.3 Horizontal beam width (3 dB)
  - DRS2D 5.2°
  - DRS4D 4.0°
  - DRS4A 2.3°
  - DRS6A 1.9°
  - DRS12A/25A 1.9° (XN12A), 1.4° (XN13A)
- 1.4 Vertical beam width (3 dB)
  - DRS2D/4D 25°
  - DRS4A/6A/12A/25A 22°
- 1.5 Gain
  - DRS2D 21.5dBi
  - DRS4D 23.0dBi
  - DRS4A 27.5dBi
  - DRS6A 28.5dBi
  - DRS12A/25A 28.5dBi (XN12A), 30dBi (XN13A)
- 1.6 Sidelobe attenuation
  - DRS2D -24 dB (within ±20°), -26 dB (±20° or more)
  - DRS4D -25 dB (within ±20°), -27 dB (±20° or more)
  - DRS4A -20 dB (within ±20°), -28 dB (±20° or more)
  - DRS6A/12A/25A -27 dB (within ±10°), -28 dB (±10° or more)
- 1.7 Rotation 24/36/48 rpm

**2 RADAR FUNCTION**

- 2.1 TX frequency 9410±30 MHz, P0N
- 2.2 Output power (nominal) DRS2D: 2.2 kW, DRS4D/4A: 4 kW, DRS6A: 6 kW, DRS12A: 12 kW  
DRS25A: 25 kW
- 2.3 Duplexer Ferrite circulator with diode limiter
- 2.4 Intermediate frequency 60 MHz
- 2.5 Range, Pulse length and Pulse Repetition Rate (PRR)

Range (nm)	Pulse length (μs)	PRR (Hz approx.)
0.125 to 1.5	0.08	3000
1.5 to 3	0.3	1500
3 to 24	0.5	1000
12 to 48	0.7	600
32 to 64 (72/96)	0.8	600 (550)

- 2.6 Maximum range DRS2D: 24 NM, DRS4D: 36 NM, DRS4A: 48 NM, DRS6A: 64 NM, DRS12A: 72 NM, DRS25A: 96 NM
- 2.7 Minimum range 25 m
- 2.8 Range resolution 20 m
- 2.9 Bearing resolution DRS2D: 5.2°, DRS4D: 4°, DRS4A: 2.3°, DRS6A: 1.9°, DRS12A/25A: 1.9° (XN12A) or 1.4° (XN13A)
- 2.10 Bearing accuracy ±1°
- 2.11 Range accuracy 0.9% of range in use or 8 m, whichever is the greater

### 3 POWER SUPPLY

- 3.1 Radar sensor 48 VDC, supplied by Multi-function display, w/o CAN bus load  
DRS2D: 0.4 A, DRS4D: 0.5 A, DRS4A: 1 A, DRS6A: 1.4 A  
DRS12A: 1.3 A
- 3.2 Radar sensor w/ power supply unit  
DRS25A + PSU-013 12-24 VDC: 10.2-4.7 A (12.0-5.6 A: wind speed 70kt)
- 3.3 Power supply unit (option) set (unit: A, 12-24 VDC, ( ): wind speed 70kt)

Model	DRS2D	DRS4D	DRS4A	DRS6A,	DRS12A
PSU-012	3.8-1.9 A	4.1-2.0	5.0-2.8 (6.2-3.0)	8.0-3.8 (8.5-4.1)	7.8-3.7 (9.8-4.7)
PSU-017	3.6-1.7 A	4.0-1.9			

### 4 ENVIRONMENTAL CONDITION

- 4.1 Ambient temperature -30°C to +55°C (storage: +70°C or less)
- 4.2 Relative humidity 95% at 40°C
- 4.3 Degree of protection  
Radar sensor IP26  
Power supply unit PSU-012/013: IPX0, PSU-017: IP25
- 4.4 Vibration IEC 60945

### 5 COATING COLOR

- 5.1 Radar sensor N9.5
- 5.2 Power supply unit N2.5



### 6 COMPASS SAFE DISTANCE

- 6.1 Radar sensor  
DRS2D Standard: 1.35 m, Steering: 0.80 m  
DRS4D Standard: 1.40 m, Steering: 0.85 m  
DRS4A Standard: 0.80 m, Steering: 0.50 m  
DRS6A Standard: 0.85 m, Steering: 0.55 m  
DRS12A Standard: 1.15 m, Steering: 0.70 m  
DRS25A Standard: 1.00 m, Steering: 0.60 m
- 6.2 Power supply unit  
PSU-012/013/017 Standard: 0.30 m, Steering: 0.30 m

# FURUNO

CODE NO.	001-025-270-00	03HA-X-9401-0
TYPE	CP03-32101	1/1

## 工事材料表

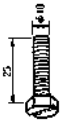
INSTALLATION MATERIALS		RSB-119-092/093/094							
番号 NO.	名称 NAME	略図 OUTLINE	用途/備考 REMARKS						
1	子付組品 RESISTOR ASSEMBLY		数量 Q'TY 1						
			<table border="1"> <tr> <td>型名/規格 DESCRIPTIONS</td> <td>120 OHM-1007#24-L50</td> </tr> <tr> <td>CODE NO.</td> <td>000-167-292-10</td> </tr> <tr> <td></td> <td>000-167-746-10</td> </tr> </table>	型名/規格 DESCRIPTIONS	120 OHM-1007#24-L50	CODE NO.	000-167-292-10		000-167-746-10
型名/規格 DESCRIPTIONS	120 OHM-1007#24-L50								
CODE NO.	000-167-292-10								
	000-167-746-10								
2	フラット平座金 FLAT WASHER		数量 Q'TY 4						
			<table border="1"> <tr> <td>型名/規格 DESCRIPTIONS</td> <td>M10 SUS304</td> </tr> <tr> <td>CODE NO.</td> <td>000-167-292-10</td> </tr> <tr> <td></td> <td>000-864-13-00</td> </tr> </table>	型名/規格 DESCRIPTIONS	M10 SUS304	CODE NO.	000-167-292-10		000-864-13-00
型名/規格 DESCRIPTIONS	M10 SUS304								
CODE NO.	000-167-292-10								
	000-864-13-00								
3	平座金 SPRING WASHER		数量 Q'TY 4						
			<table border="1"> <tr> <td>型名/規格 DESCRIPTIONS</td> <td>M10 SUS304</td> </tr> <tr> <td>CODE NO.</td> <td>000-167-233-10</td> </tr> <tr> <td></td> <td>000-864-261-00</td> </tr> </table>	型名/規格 DESCRIPTIONS	M10 SUS304	CODE NO.	000-167-233-10		000-864-261-00
型名/規格 DESCRIPTIONS	M10 SUS304								
CODE NO.	000-167-233-10								
	000-864-261-00								
4	六角スリットボルト HEX. BOLT (SLOTTED HEAD)		数量 Q'TY 4						
			<table border="1"> <tr> <td>型名/規格 DESCRIPTIONS</td> <td>M10X25 SUS304</td> </tr> <tr> <td>CODE NO.</td> <td>000-162-883-10</td> </tr> </table>	型名/規格 DESCRIPTIONS	M10X25 SUS304	CODE NO.	000-162-883-10		
型名/規格 DESCRIPTIONS	M10X25 SUS304								
CODE NO.	000-162-883-10								







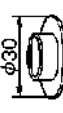
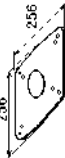

型式/コード番号が2段の場合、下段より上段に代わる通称部品であり、どちらが入っています。なお、品質は変わりません。  
 TWO TYPES AND CODES MAY BE LISTED FOR AN ITEM. THE LOWER PRODUCT MAY BE SHIPPED IN PLACE OF THE UPPER PRODUCT. QUALITY IS THE SAME.  
 (略図の寸法は、参考値です。 DIMENSIONS IN DRAWING FOR REFERENCE ONLY.)

FURUNO ELECTRIC CO., LTD.

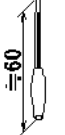
# FURUNO

CODE NO.	001-025-780-00	03BY-X-9401-3
TYPE	CP03-32601	1/2

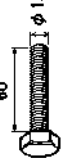
## 工事材料表

INSTALLATION MATERIALS		RSB-119-092/093/094					
番号 NO.	名称 NAME	略図 OUTLINE	用途/備考 REMARKS				
1	シーリングワッシャー SEAL WASHER		数量 Q'TY 4				
			<table border="1"> <tr> <td>型名/規格 DESCRIPTIONS</td> <td>03-001-3002-0 ROHS</td> </tr> <tr> <td>CODE NO.</td> <td>300-130-020-10</td> </tr> </table>	型名/規格 DESCRIPTIONS	03-001-3002-0 ROHS	CODE NO.	300-130-020-10
型名/規格 DESCRIPTIONS	03-001-3002-0 ROHS						
CODE NO.	300-130-020-10						
2	防蝕ゴム CORROSION-PROOF RUBBER MAT		数量 Q'TY 1				
			<table border="1"> <tr> <td>型名/規格 DESCRIPTIONS</td> <td>03-142-3001-0 ROHS</td> </tr> <tr> <td>CODE NO.</td> <td>100-275-580-10</td> </tr> </table>	型名/規格 DESCRIPTIONS	03-142-3001-0 ROHS	CODE NO.	100-275-580-10
型名/規格 DESCRIPTIONS	03-142-3001-0 ROHS						
CODE NO.	100-275-580-10						
3	キャップ KNOB CAP		数量 Q'TY 4				
			<table border="1"> <tr> <td>型名/規格 DESCRIPTIONS</td> <td>040-4010</td> </tr> <tr> <td>CODE NO.</td> <td>000-164-929-10</td> </tr> </table>	型名/規格 DESCRIPTIONS	040-4010	CODE NO.	000-164-929-10
型名/規格 DESCRIPTIONS	040-4010						
CODE NO.	000-164-929-10						
4	子付組品 RESISTOR ASSEMBLY		数量 Q'TY 1				
			<table border="1"> <tr> <td>型名/規格 DESCRIPTIONS</td> <td>120 OHM-1007#24-L50</td> </tr> <tr> <td>CODE NO.</td> <td>000-167-746-10</td> </tr> </table>	型名/規格 DESCRIPTIONS	120 OHM-1007#24-L50	CODE NO.	000-167-746-10
型名/規格 DESCRIPTIONS	120 OHM-1007#24-L50						
CODE NO.	000-167-746-10						
5	平座金 SPRING WASHER		数量 Q'TY 4				
			<table border="1"> <tr> <td>型名/規格 DESCRIPTIONS</td> <td>M12 SUS304</td> </tr> <tr> <td>CODE NO.</td> <td>000-167-397-10</td> </tr> </table>	型名/規格 DESCRIPTIONS	M12 SUS304	CODE NO.	000-167-397-10
型名/規格 DESCRIPTIONS	M12 SUS304						
CODE NO.	000-167-397-10						
6	フラット平座金 FLAT WASHER		数量 Q'TY 4				
			<table border="1"> <tr> <td>型名/規格 DESCRIPTIONS</td> <td>M12 SUS304</td> </tr> <tr> <td>CODE NO.</td> <td>000-167-446-10</td> </tr> </table>	型名/規格 DESCRIPTIONS	M12 SUS304	CODE NO.	000-167-446-10
型名/規格 DESCRIPTIONS	M12 SUS304						
CODE NO.	000-167-446-10						
7	六角ナット HEXAGONAL NUT		数量 Q'TY 4				
			<table border="1"> <tr> <td>型名/規格 DESCRIPTIONS</td> <td>M12 SUS304</td> </tr> <tr> <td>CODE NO.</td> <td>000-167-491-10</td> </tr> </table>	型名/規格 DESCRIPTIONS	M12 SUS304	CODE NO.	000-167-491-10
型名/規格 DESCRIPTIONS	M12 SUS304						
CODE NO.	000-167-491-10						
8	六角ボルト 全ネジ HEXAGON HEAD SCREW		数量 Q'TY 4				
			<table border="1"> <tr> <td>型名/規格 DESCRIPTIONS</td> <td>M12X60 SUS304</td> </tr> <tr> <td>CODE NO.</td> <td>000-162-813-10</td> </tr> </table>	型名/規格 DESCRIPTIONS	M12X60 SUS304	CODE NO.	000-162-813-10
型名/規格 DESCRIPTIONS	M12X60 SUS304						
CODE NO.	000-162-813-10						
9	六角ナット HEXAGONAL NUT		数量 Q'TY 1				
			<table border="1"> <tr> <td>型名/規格 DESCRIPTIONS</td> <td>M6 SUS304</td> </tr> <tr> <td>CODE NO.</td> <td>000-158-856-10</td> </tr> </table>	型名/規格 DESCRIPTIONS	M6 SUS304	CODE NO.	000-158-856-10
型名/規格 DESCRIPTIONS	M6 SUS304						
CODE NO.	000-158-856-10						
10	平座金 SPRING WASHER		数量 Q'TY 1				
			<table border="1"> <tr> <td>型名/規格 DESCRIPTIONS</td> <td>M6 SUS304</td> </tr> <tr> <td>CODE NO.</td> <td>000-158-855-10</td> </tr> </table>	型名/規格 DESCRIPTIONS	M6 SUS304	CODE NO.	000-158-855-10
型名/規格 DESCRIPTIONS	M6 SUS304						
CODE NO.	000-158-855-10						

型式/コード番号が2段の場合、下段より上段に代わる通称部品であり、どちらが入っています。なお、品質は変わりません。  
 TWO TYPES AND CODES MAY BE LISTED FOR AN ITEM. THE LOWER PRODUCT MAY BE SHIPPED IN PLACE OF THE UPPER PRODUCT. QUALITY IS THE SAME.  
 (略図の寸法は、参考値です。 DIMENSIONS IN DRAWING FOR REFERENCE ONLY.)

FURUNO ELECTRIC CO., LTD.

# FURUNO

## 工事材料表

### INSTALLATION MATERIALS

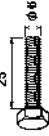
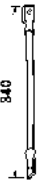
番号 NO.	名称 NAME	略図 OUTLINE	型名/規格 DESCRIPTIONS	数量 Q'TY	用途/備考 REMARKS
RSB-118-092/093/094					
036Y-X-9401-3					
CP03-32601					
2/2					
11	辺平座金 FLAT WASHER		M6 SUS304 CODE NO. 000-158-854-10	3	
12	六角ボルト HEXAGONAL HEAD BOLT		M6X25 SUS304 CODE NO. 000-162-871-10	1	
13	ケーブル組品 CABLE ASSY.		RW-4747 RW-4747-1 CODE NO. 000-566-000-12 000-566-000-01	1	



型式/コード番号が2段の場合、下段より上段に代わる選定部品であり、どちらが入っています。なお、品質は変わりません。  
TWO TYPES AND CODES MAY BE LISTED FOR AN ITEM. THE LOWER PRODUCT MAY BE SHIPPED IN PLACE OF THE UPPER PRODUCT.  
QUALITY IS THE SAME.  
(略図の寸法は、参考値です。 DIMENSIONS IN DRAWING FOR REFERENCE ONLY.)

FURUNO ELECTRIC CO., LTD. C3569-M01-D (2)

# FURUNO

## 工事材料表

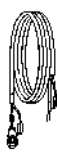
### INSTALLATION MATERIALS

番号 NO.	名称 NAME	略図 OUTLINE	型名/規格 DESCRIPTIONS	数量 Q'TY	用途/備考 REMARKS
RADAR SENSOR					
DRS2D/4D, DRS4A/6A/12A					
03HA-X-9402-1					
1/1					
1	ケーブル組品 CABLE ASSY.		MOD-ASW0001-100+ CODE NO. 000-167-635-00	1	選択 TO BE SELECTED
2	ケーブル組品 CABLE ASSY.		MOD-ASW0001-150+ CODE NO. 000-167-636-00	1	選択 TO BE SELECTED
3	ケーブル組品 CABLE ASSY.		MOD-ASW0001-200+ CODE NO. 000-167-637-00	1	選択 TO BE SELECTED
4	ケーブル組品 CABLE ASSY.		MOD-ASW0001-300+ CODE NO. 000-167-638-00	1	選択 TO BE SELECTED

標準は15mであるが必要により選択可  
STANDARD LENGTH IS 15M. OTHER LENGTHS ARE ALSO AVAILABLE.  
型式/コード番号が2段の場合、下段より上段に代わる選定部品であり、どちらが入っています。なお、品質は変わりません。  
TWO TYPES AND CODES MAY BE LISTED FOR AN ITEM. THE LOWER PRODUCT MAY BE SHIPPED IN PLACE OF THE UPPER PRODUCT.  
QUALITY IS THE SAME.  
(略図の寸法は、参考値です。 DIMENSIONS IN DRAWING FOR REFERENCE ONLY.)





FURUNO ELECTRIC CO., LTD.

C3567-M02-B

# FURUNO

## 工事材料表

### INSTALLATION MATERIALS

番号 NO.	名称 NAME	略図 OUTLINE	型名/規格 DESCRIPTIONS		数量 QTY	用途/備考 REMARKS
			CODE NO.	000-167-639-00		
1	ケーブル組品 CABLE ASSY.	 L=10M	MOD-ASN0002-100+		1	*選択 TO BE SELECT
			CODE NO.	000-167-639-00		
2	ケーブル組品 CABLE ASSY.	 L=15M	MOD-ASN0002-150+		1	*選択 TO BE SELECT
			CODE NO.	000-167-640-00		
3	ケーブル組品 CABLE ASSY.	 L=20M	MOD-ASN0002-200+		1	*選択 TO BE SELECT
			CODE NO.	000-167-641-00		
4	ケーブル組品 CABLE ASSY.	 L=30M	MOD-ASN0002-300+		1	*選択 TO BE SELECT
			CODE NO.	000-167-642-00		

型式/コード番号が2段の場合、下段より上段に代わる選定部品であり、どちらが入っています。なお、品質は変わりません。  
 TWO TYPES AND CODES MAY BE LISTED FOR AN ITEM. THE LOWER PRODUCT MAY BE SHIPPED IN PLACE OF THE UPPER PRODUCT. QUALITY IS THE SAME.  
 (略図の寸法は、参考値です。DIMENSIONS IN DRAWING FOR REFERENCE ONLY.)

FURUNO ELECTRIC CO., LTD.

C3573-M02-A

表 1 TABLE 1

寸法区分 (mm) DIMENSION	公差 (mm) TOLERANCE
$L \leq 50$	$\pm 1.5$
$50 < L \leq 100$	$\pm 2.5$
$100 < L \leq 500$	$\pm 3$

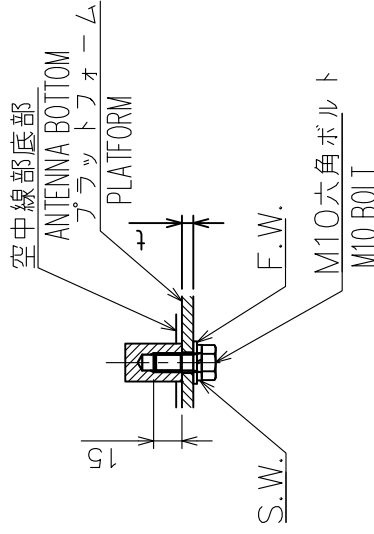
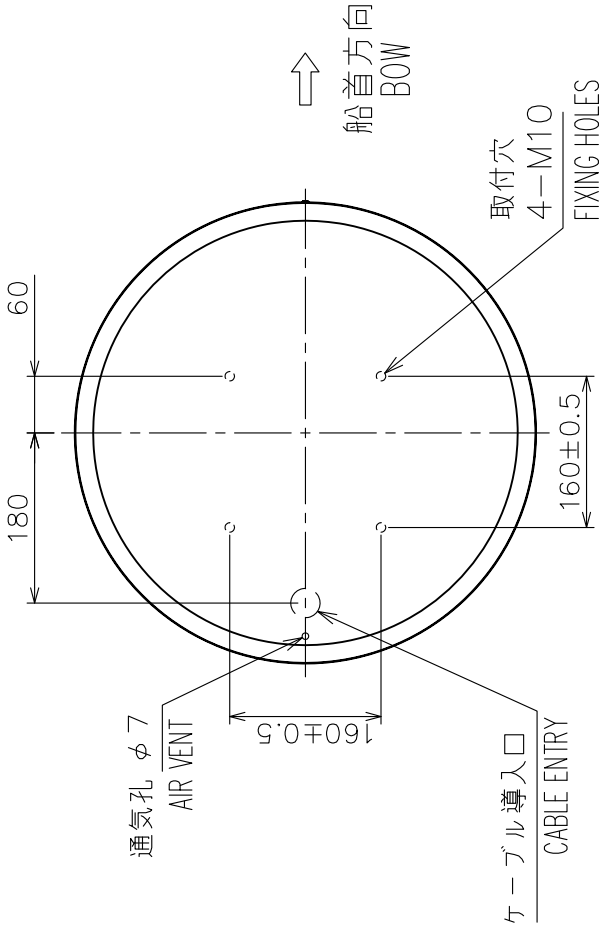

A部 詳細 (尺度 1/4)  
DETAIL OF A (SCALE: 1/4)

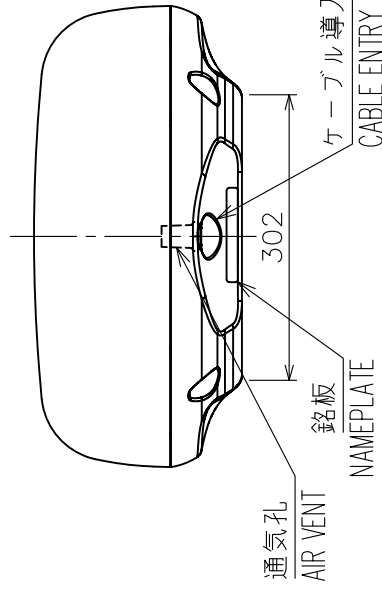
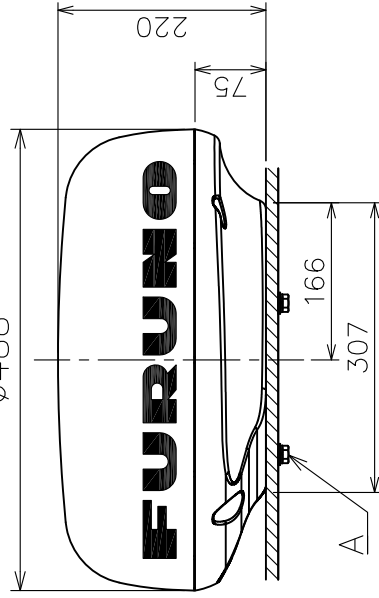

注 記

- 1) 指定外の寸法公差は表 1 による。
- 2) 取付用ネジは M10 ボルトを使用のこと。ネジ長さは板厚 t に応じて、 $20 (t \leq 5)$  または  $25 (5 < t \leq 10)$  とする。

NOTE

1. TABLE 1 INDICATES TOLERANCE OF DIMENSIONS WHICH IS NOT SPECIFIED.
2. USE M10 BOLTS FOR FIXING THE UNIT. SCREW LENGTH SHOULD BE  $20 (t \leq 5)$  OR  $25 (5 < t \leq 10)$ . t: THICKNESS OF PLATFORM

DRAWN	17/Aug/09 I. YAMASAKI	TITLE	DRS2D
CHECKED	17/Aug/09 I. TAKENO	名 称	レーダーセンサー
APPROVED	21/Aug/09 R. Esumi	外 寸 図	
SCALE	1/8 MASS 6.5 kg	NAME	RADAR SENSOR
DWG.No.	C3567-G01-B	REF.No.	03-174-300G-1
			OUTLINE DRAWING

# FURUNO

表 1 TABLE 1

寸法区分 (mm) DIMENSION	公差 (mm) TOLERANCE
L ≤ 50	± 1.5
50 < L ≤ 100	± 2.5
100 < L ≤ 500	± 3

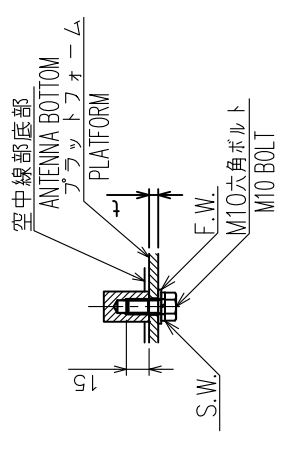
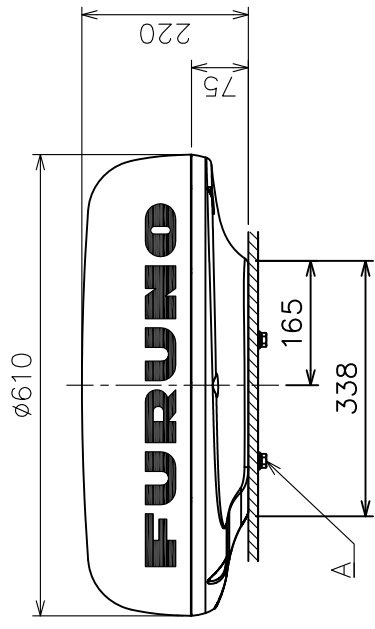
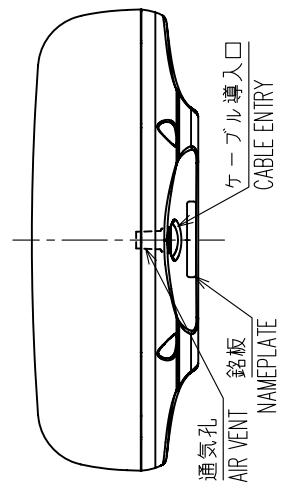
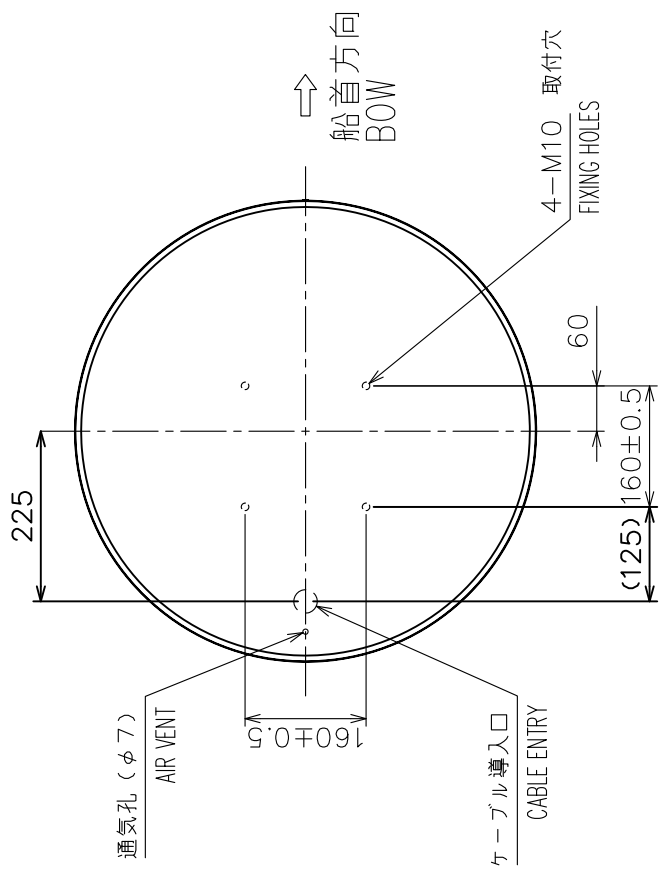

A部 詳細 (尺度 1/5)  
DETAIL OF A (SCALE: 1/5)

注 記

- 1) 指定外の寸法公差は表 1 による。
- 2) 取付用ネジは M10 ボルトを使用のこと。ネジ長さは板厚 t に応じて、20 (t ≤ 5) または 25 (5 < t ≤ 10) とする。

NOTE

1. TABLE 1 INDICATES TOLERANCE OF DIMENSIONS WHICH IS NOT SPECIFIED.
2. USE M10 BOLTS FOR FIXING THE UNIT. SCREW LENGTH SHOULD BE 20 (t ≤ 5) OR 25 (5 < t ≤ 10). t: THICKNESS OF PLATFORM

DRAWN	10/Mar/08 I.YAMASAKI	TITLE	DRS4D
CHECKED	10/Mar/08 I.TAKENO	名#	レーダーセンサー
APPROVED	22/Mar/08 R. Esumi	外寸図	
SCALE	1/10 MASS 7.5 t/07	NAME	RADAR SENSOR
DWG.No.	C3568-G01-B	REF.No.	03-174-310G-1
			OUTLINE DRAWING

# FURUNO ELECTRIC CO., LTD.



表 1 TABLE 1

機種型式 MODEL	DRS4A	DRS6A	DRS12A DRS25A	DRS12A DRS25A
輻射器 RADIATOR	XN10A	XN12A	XN12A	XN13A
空中線長 (A) ANT. LENGTH (mm)	1036±10	1255±10	1255±10	1795±10
回転安全空間 (B) ANT. CLEARANCE (mm)	1200	1400	1400	1940
質量 (kg±10%) MASS	25	25	26	28

表 2 TABLE 2

寸法区分 (mm) DIMENSION	公差 (mm) TOLERANCE
L ≤ 50	±1.5
50 < L ≤ 100	±2.5
100 < L ≤ 500	±3
500 < L ≤ 1000	±4
1000 < L ≤ 2000	±5

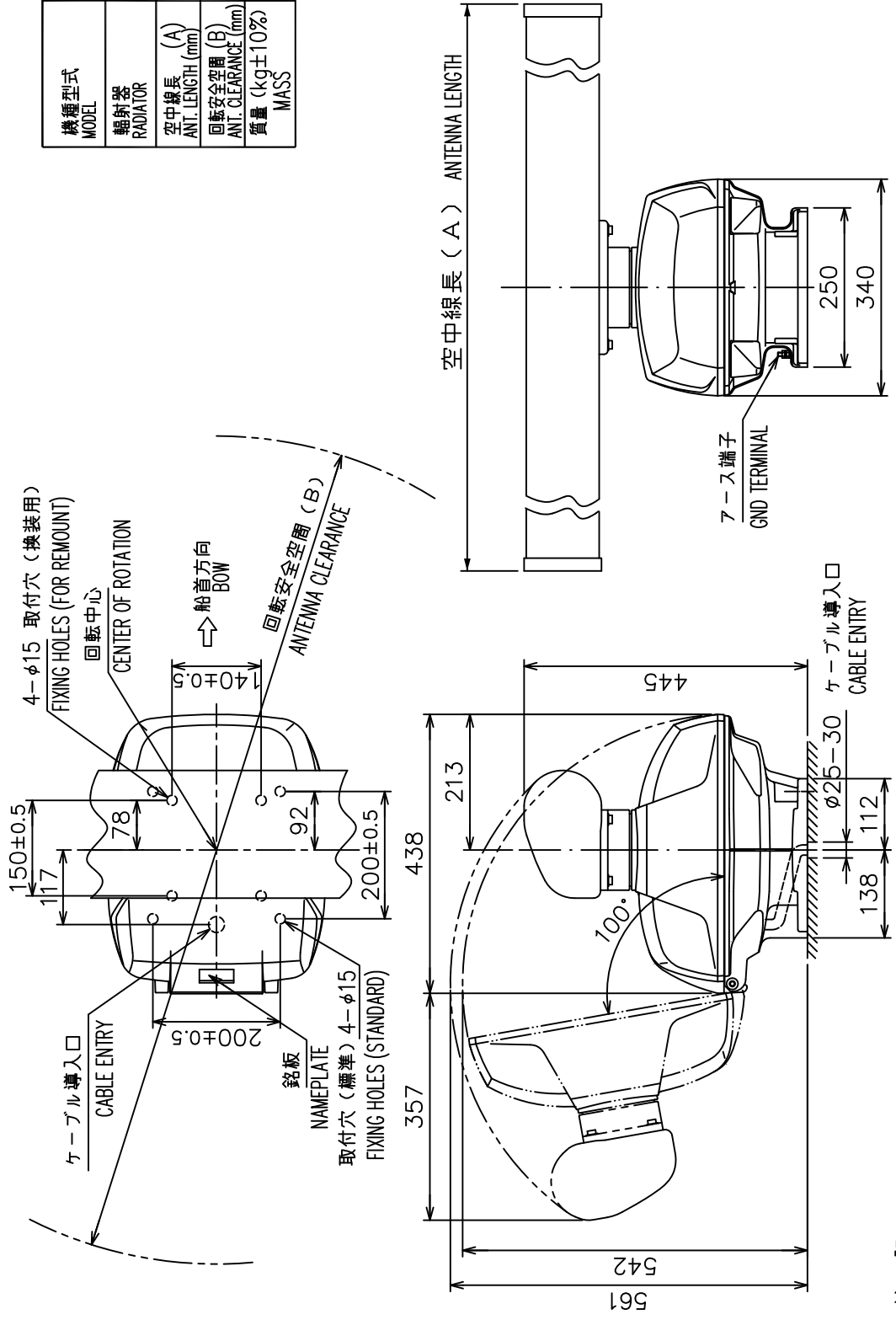

注 記

- 1) 指定寸法公差は表 2 による。
- 2) 取付は M12 ボルトを使用のこと。

NOTE

1. TABLE 2 INDICATES TOLERANCE OF DIMENSIONS WHICH IS NOT SPECIFIED.
2. USE M12 BOLTS FOR FIXING THE UNIT.

DRAWN	Jan. 17 '08	I. YAMASAKI	TITLE	RSB-118
CHECKED	Jan. 17 '08	I. TAKENO	名称	空中線部
APPROVED	Jan. 18 '08	R. ESUMI	外寸図	
SCALE	1/10	質量 表 1 参照 SEE TABLE 1	NAME	ANTENNA UNIT
DWG. No.	C3569-G01-B	REF. No.	03-174-504G-2	OUTLINE DRAWING

表 1 TABLE 1

寸法区分 (mm) DIMENSION	公差 (mm) TOLERANCE
L ≤ 50	±1.5
50 < L ≤ 100	±2.5
100 < L ≤ 500	±3

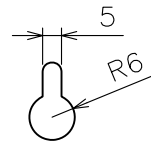
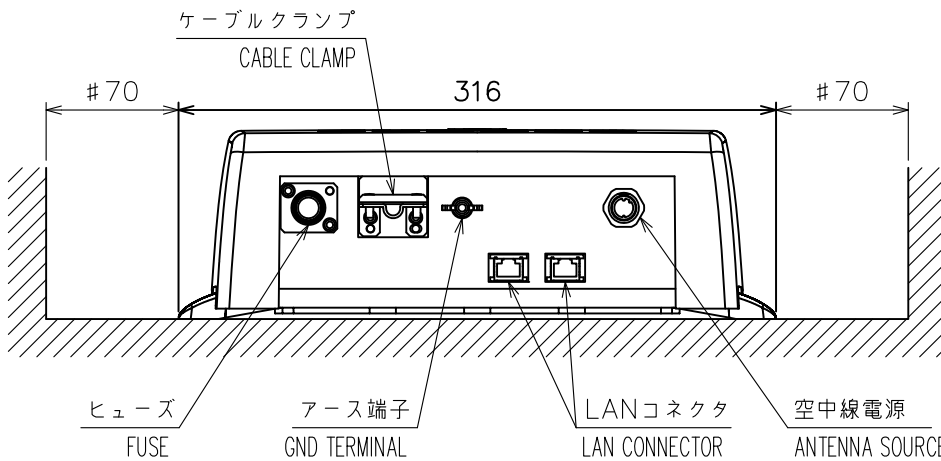
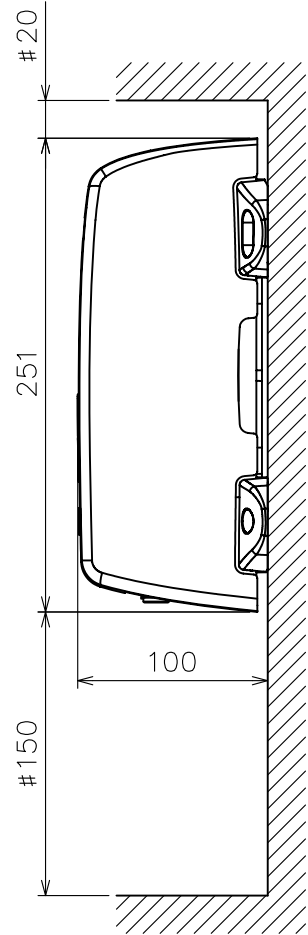
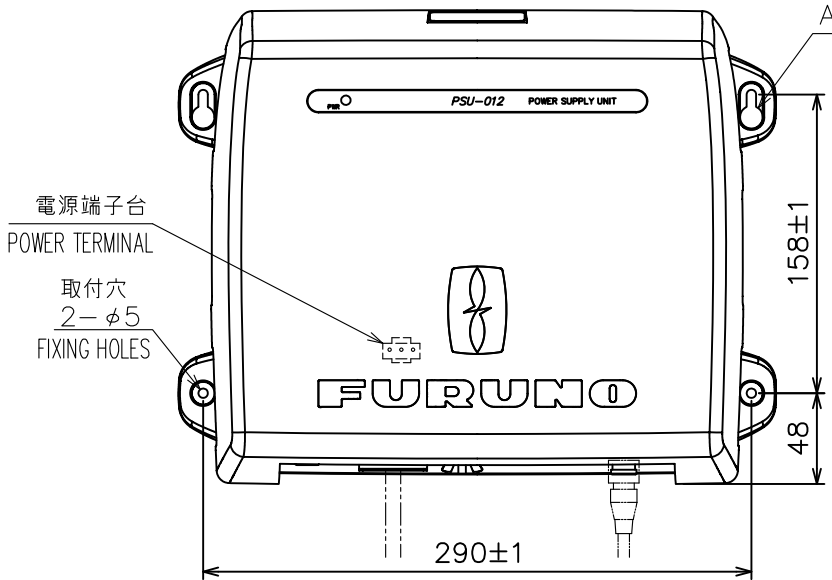
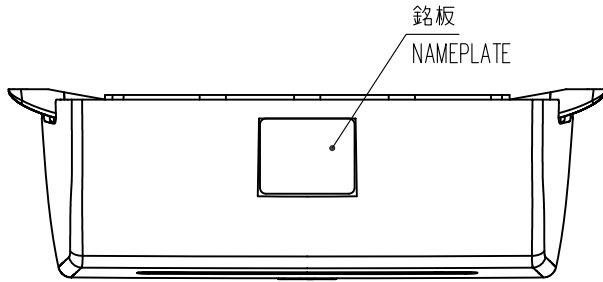

A部詳細 (縮尺: 1/2)  
DETAIL OF A (SCALE: 1/2)

- 注 記 1) #印寸法は最小サービス空間寸法とする。  
2) 指定外の寸法公差は表 1 による。  
3) 取付用ネジはトラスタッピンネジ呼び径4×20を使用のこと。

- NOTE 1. #: MINIMUM SERVICE CLEARANCE.  
2. TABLE 1 INDICATES TOLERANCE OF DIMENSIONS WHICH IS NOT SPECIFIED.  
3. USE TAPPING SCREWS φ4x20 FOR FIXING THE UNIT.

DRAWN	1/Apr/08 T.YAMASAKI	TITLE	PSU-012
CHECKED	1/Apr/08 T.TAKENO	名称	パワーサプライユニット
APPROVED	2/Apr/08 R.Esumi	DRS4A/6A/12A	外寸図
SCALE	1/4 MASS 1.8 ±10% kg	NAME	POWER SUPPLY UNIT
DWG.No.	C3569-G02-D	REF.No.	03-174-900G-2
		OUTLINE DRAWING	

表 1 TABLE 1

寸法区分 (mm) DIMENSION	公差 (mm) TOLERANCE
$L \leq 50$	$\pm 1.5$
$50 < L \leq 100$	$\pm 2.5$
$100 < L \leq 500$	$\pm 3$

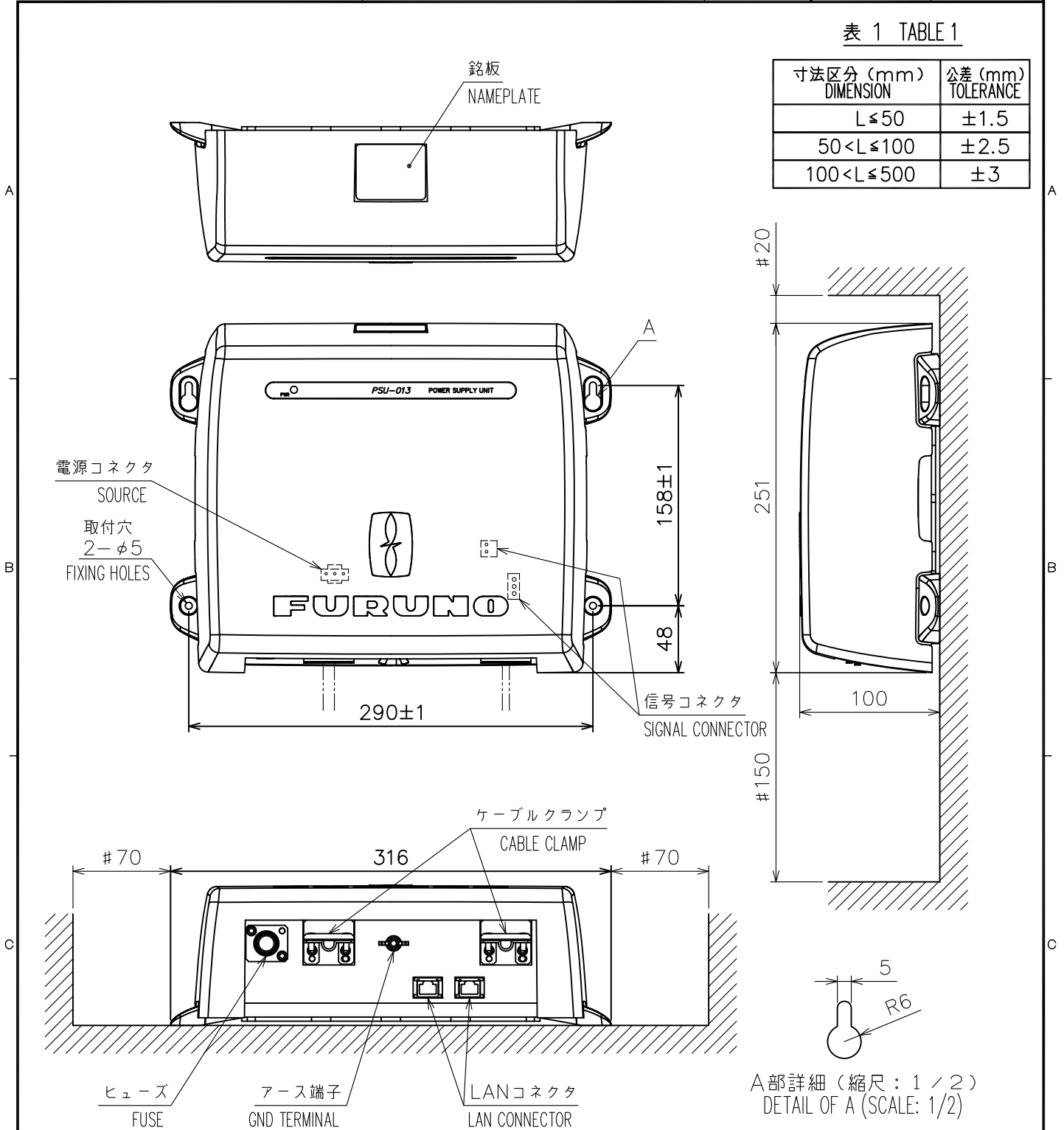

- 注 記 1) #印寸法は最小サービス空間寸法とする。  
 2) 指定外の寸法公差は表 1 による。  
 3) 取付用ネジはトラスタッピンネジ呼び径4×20を使用のこと。

- NOTE 1. #: MINIMUM SERVICE CLEARANCE.  
 2. TABLE 1 INDICATES TOLERANCE OF DIMENSIONS WHICH IS NOT SPECIFIED.  
 3. USE TAPPING SCREWS  $\phi 4 \times 20$  FOR FIXING THE UNIT.

DRAWN 15/Apr/08 I.YAMASAKI	TITLE PSU-013
CHECKED 15/Apr/08 T.TAKENO	名称 パワーサプライユニット
APPROVED 28/Apr/08 R.Esumi	DRS25A 外寸図
SCALE 1/4 MASS 1.8 ±10% kg	NAME POWER SUPPLY UNIT
DWG.No. C3573-G01-B	REF.No. 03-174-910G-2 OUTLINE DRAWING

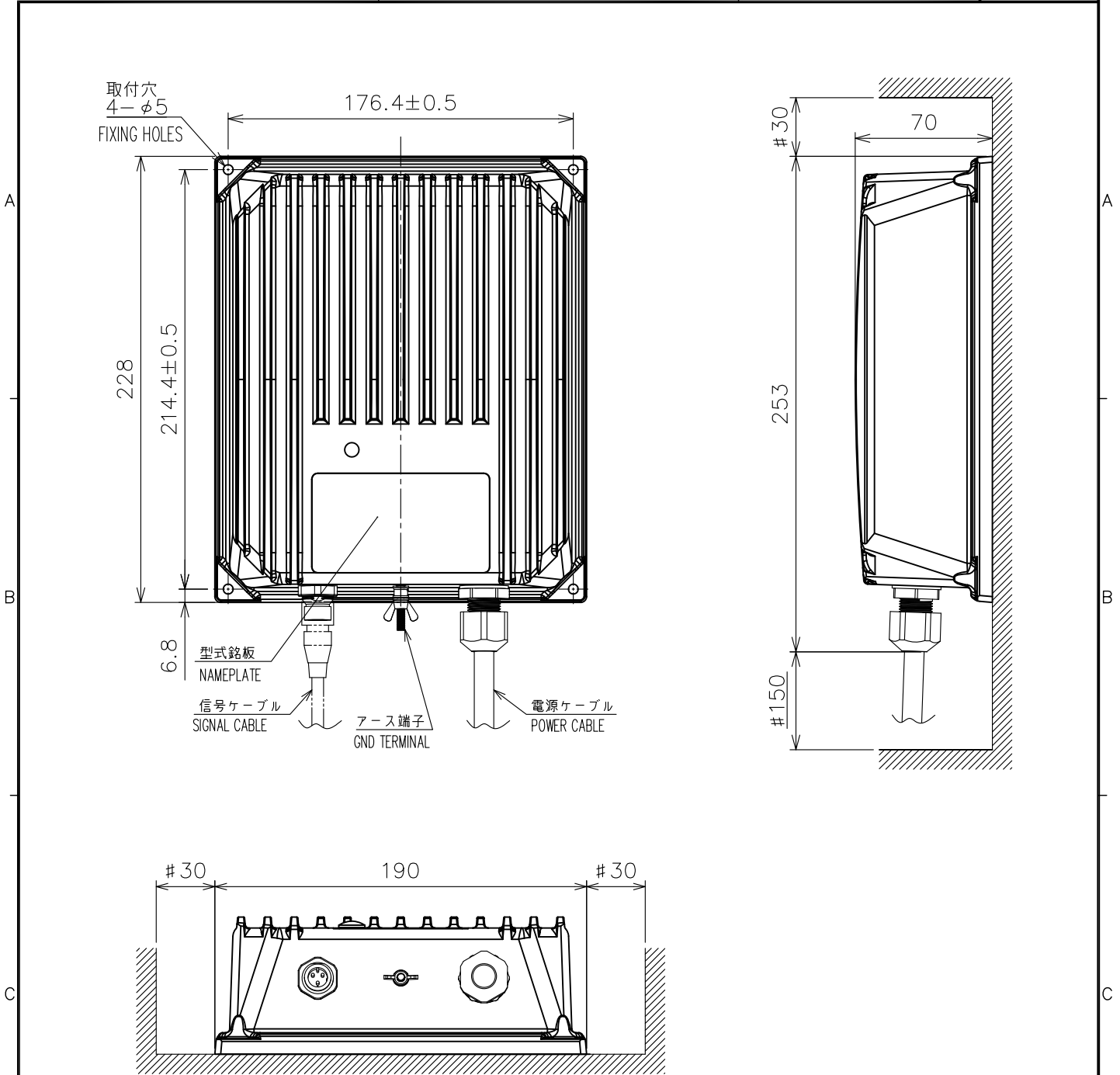

注 記

- 1) 指定外の寸法公差は表1による。
- 2) #印寸法は最小サービス空間寸法とする。
- 3) 取付用ネジは+トラスタッピンネジ呼び径4×20を使用のこと。

NOTE

1. TABLE 1 INDICATES TOLERANCE OF DIMENSIONS WHICH IS NOT SPECIFIED.
2. #: MINIMUM SERVICE CLEARANCE.
3. USE TAPPING SCREWS  $\phi 4 \times 20$  FOR FIXING THE UNIT.

表 1 TABLE 1

寸法区分 (mm) DIMENSION	公差 (mm) TOLERANCE
$L \leq 50$	$\pm 1.5$
$50 < L \leq 100$	$\pm 2.5$
$100 < L \leq 500$	$\pm 3$

DRAWN	15/Oct/2012 I.YAMASAKI	TITLE	PSU-017
CHECKED	15/Oct/2012 H.MAKI	名称	パワーサプライユニット
APPROVED	16/Oct/2012 Y.NISHIYAMA	DRS2D/4D	外寸図
SCALE	1/3	MASS	2.3 $\pm 10\%$ kg
			質量は電源ケーブル (5m) を含む。 MASS INCLUDES 5m POWER CABLE.
DWG. No.	C3567-G02-B	REF. No.	03-181-900G-C
			NAME POWER SUPPLY UNIT
			OUTLINE DRAWING

1

2

3

4

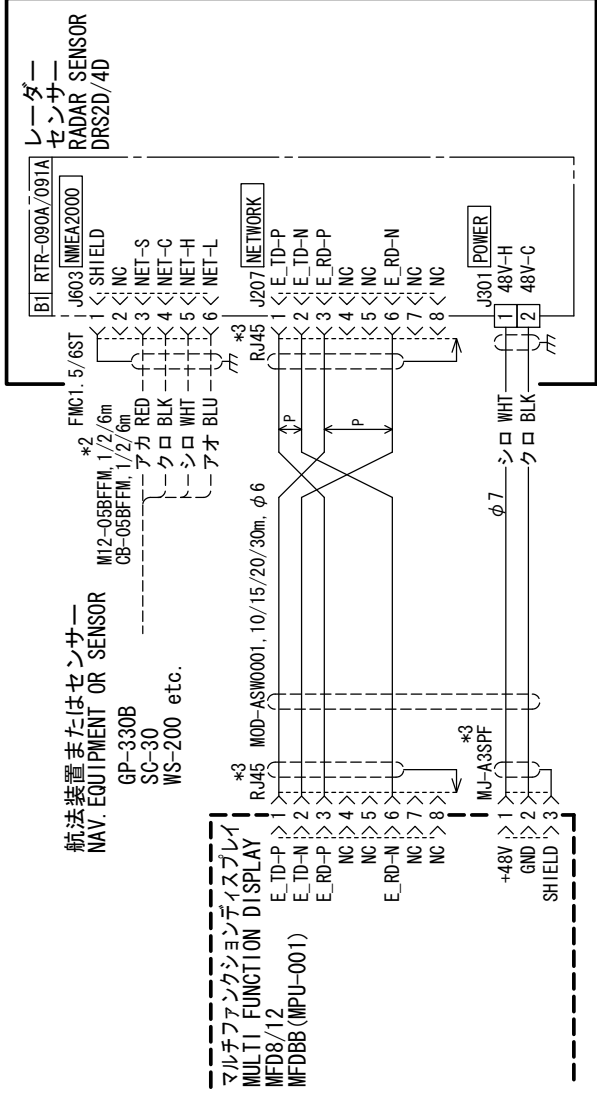

TZT9/14をレーダーセンサーに接続するときは、PSU-012またはPSU-017が必要。  
PSU-017はブレーカを介して電源に接続すること。  
TZT9/14 REQUIRES PSU-012 OR PSU-017 TO CONNECT A RADAR SENSOR.  
PSU-017 REQUIRES BREAKER TO CONNECT SOURCE.

または、  
OR

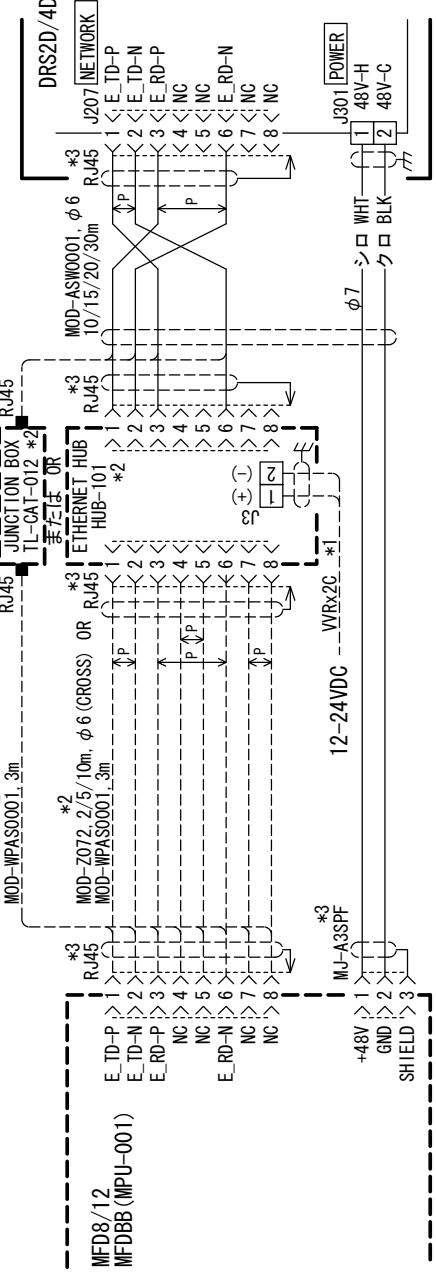

注記

- 1) 造船所手配。
- 2) オプション。
- 3) コネクタは工場にて取付済み。

NOTE

1. SHIPYARD SUPPLY.
2. OPTION.
3. CONNECTOR PLUG FITTED AT FACTORY.

DRAWN	18/Oct/2012	I. YAMASAKI	TITLE	DRS2D/4D
CHECKED	18/Oct/2012	H. MAKI	名称	レーダーセンサー
APPROVED	22/Oct/2012	Y. NISHIYAMA		相互結線図
SCALE		1/ASS	NAME	RADAR SENSOR
DWG. No.	C3567-C01-D	REF. No.	03-174-6001-2	
INTERCONNECTION DIAGRAM				

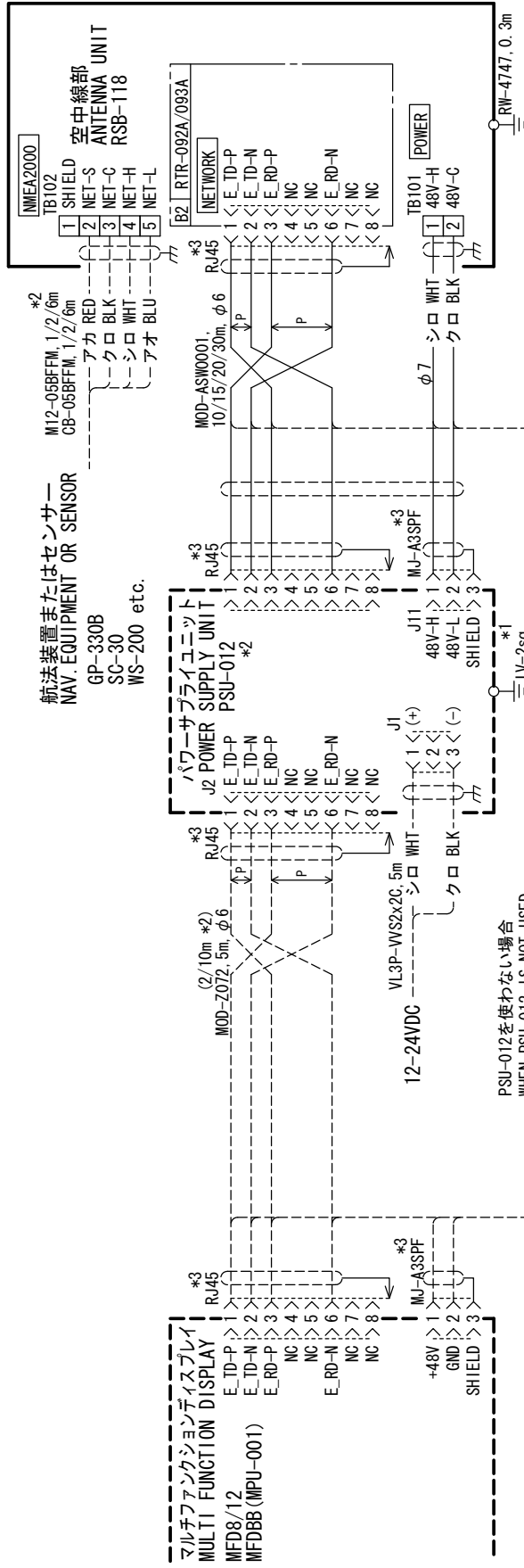

A

B

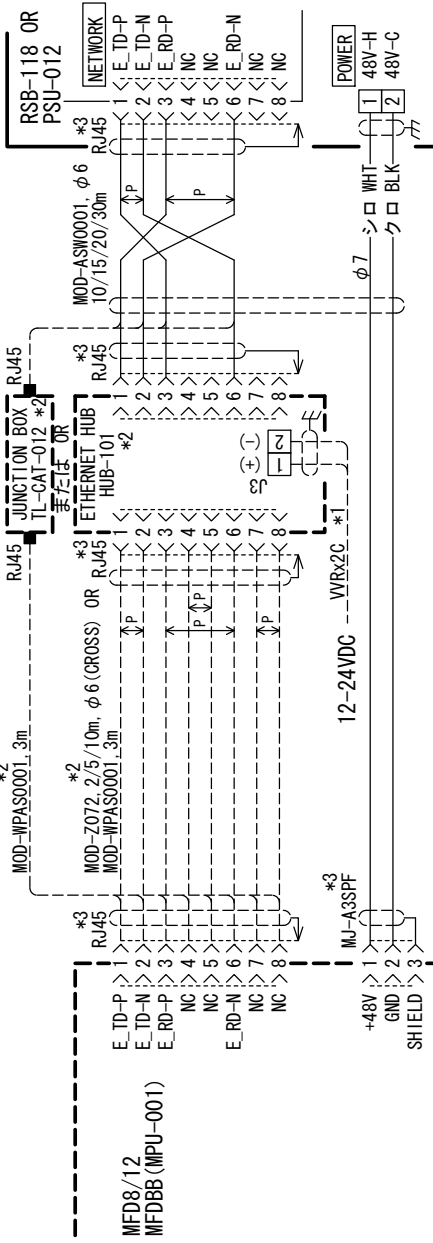

C

### 注記

- 1) 造船所手配。
- 2) オプション。
- 3) コネクタは工場にて取付済み。

### NOTE

- 1. SHIPYARD SUPPLY.
- 2. OPTION.
- 3. CONNECTOR PLUG FITTED AT FACTORY.

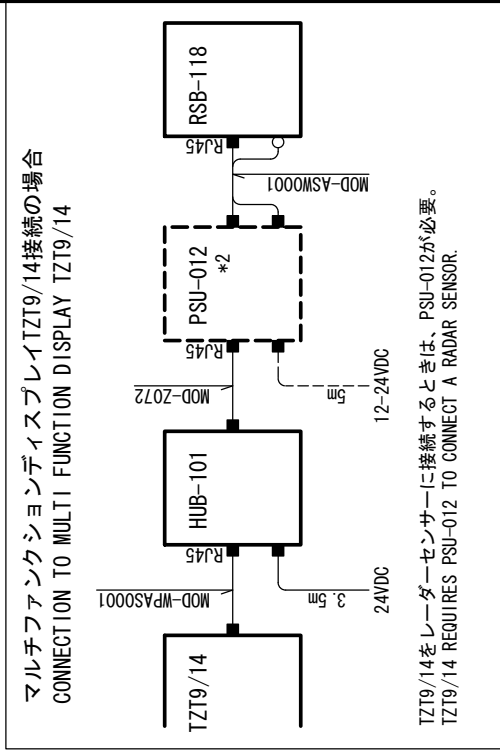

B

DRAWN	10/Feb/2012	I. YAMASAKI	TITLE	DRS4A/6A
CHECKED	10/Feb/2012	H. MAKI	名称	レーダーセンサー
APPROVED	13/Feb/2012	Y. NISHIYAMA	相互結線図	
SCALE		1/100	NAME	RADAR SENSOR
DWG. No.	C3569-C01-E	kg	INTERCONNECTION DIAGRAM	
REF. No.	03-174-6003-4			

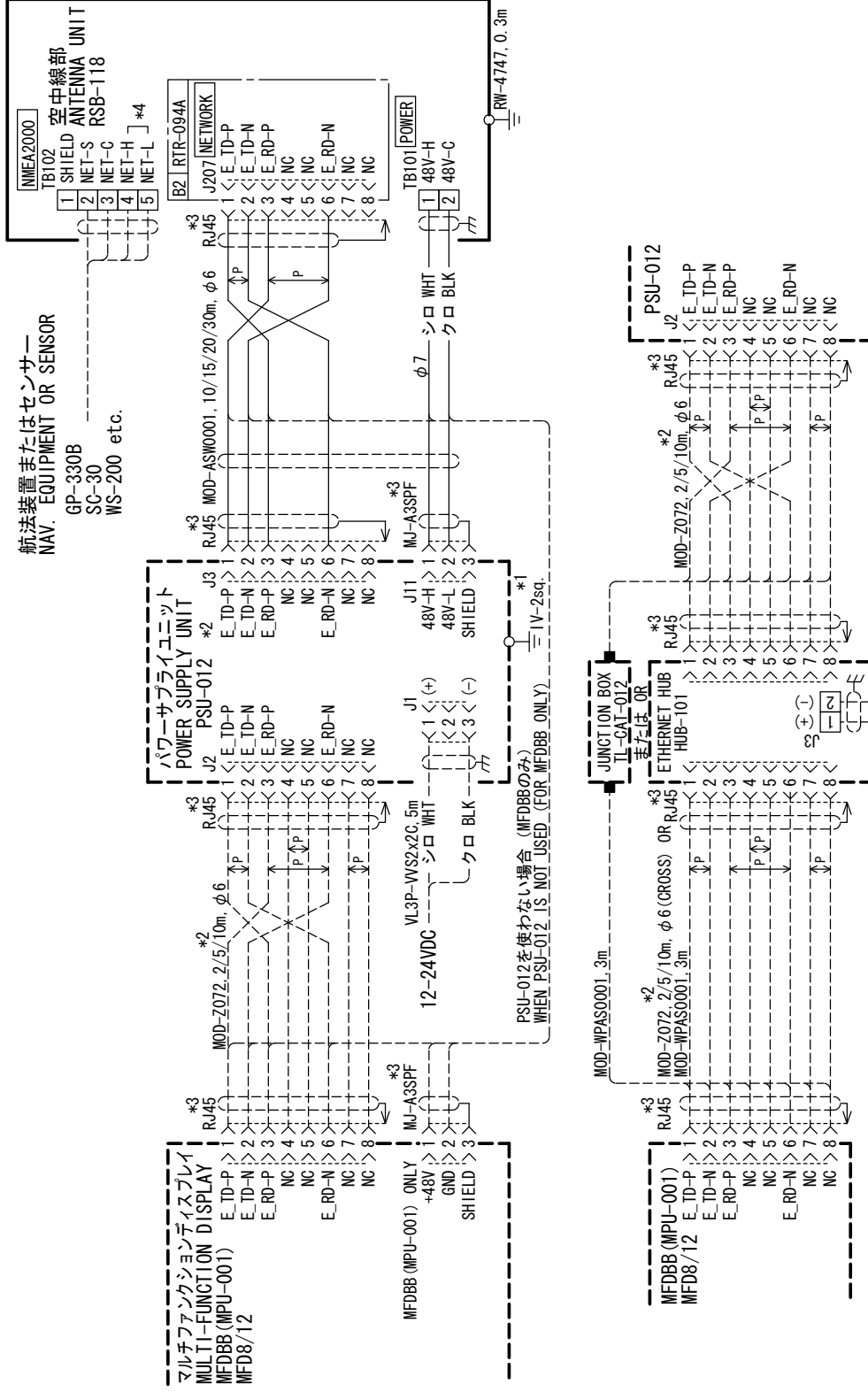

**注記**

- \* 1) 造船所手配。
- \* 2) オプション。
- \* 3) コネクタは工場にて取付済み。
- \* 4) ターミネータを接続する。

**NOTE**

- \*1: SHIPYARD SUPPLY.
- \*2: OPTION.
- \*3: CONNECTOR PLUG FITTED AT FACTORY.
- \*4: ATTACH A TERMINATOR.

DRAWN	25/May/2011	T. YAMASAKI	TITLE	DRS12A
CHECKED	25/May/2011	H. MAKI	名称	レーダーセンサー
APPROVED	25/May/2011	Y. NISHIYAMA		相互結線図
SCALE		MASS kg	NAME	RADAR SENSOR
DWG. No.	C3571-C01-E	REF. No.	03-174-6003-4	INTERCONNECTION DIAGRAM

1 2 3 4

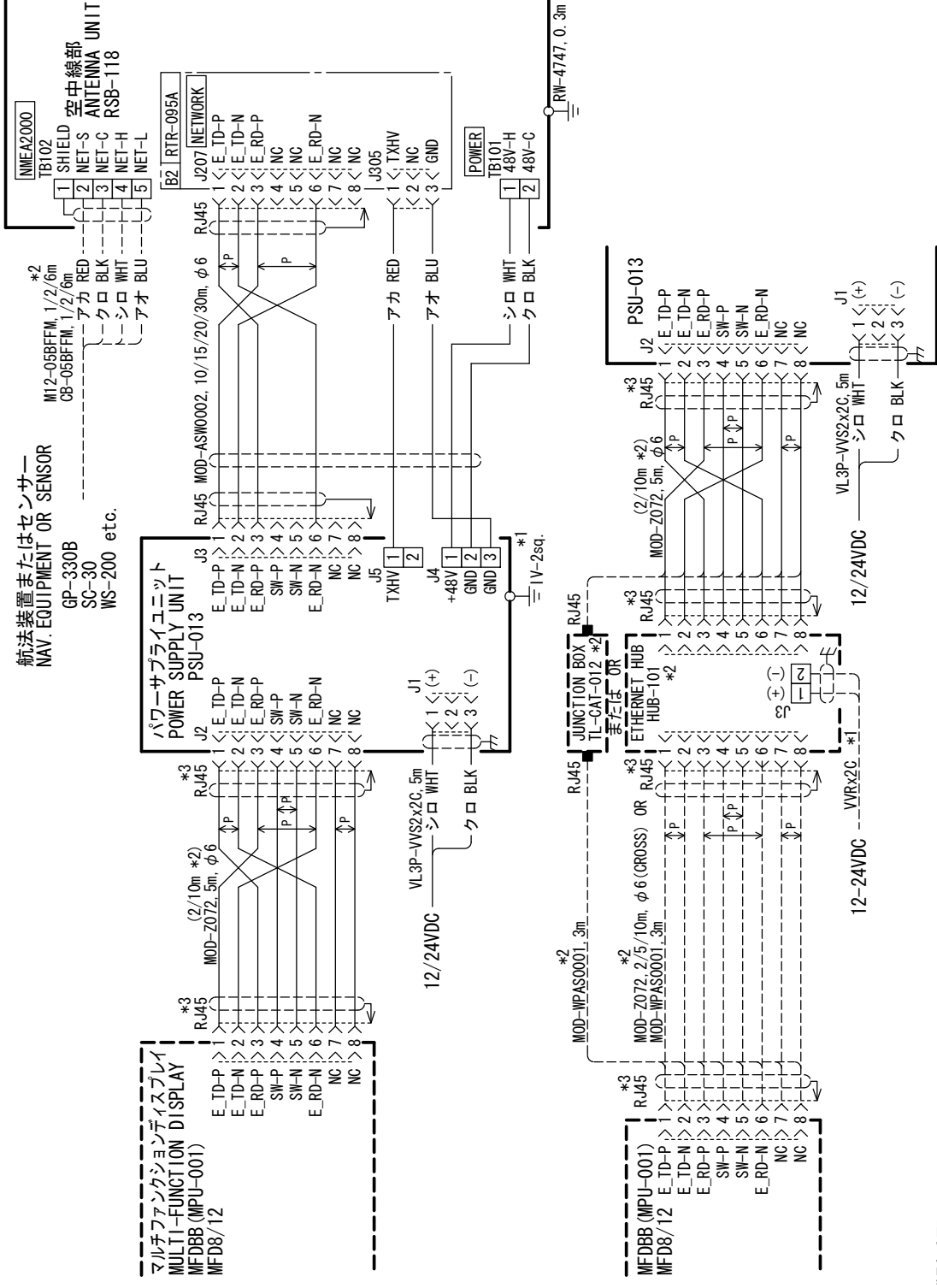

- 注記  
 1) 造船所手配。  
 2) オプション。  
 3) コネクタは工場にて取付済み。
- NOTE  
 1. SHIPYARD SUPPLY.  
 2. OPTION.  
 3. CONNECTOR PLUG FITTED AT FACTORY.

DRAWN 25/May/2011 I. YAMASAKI	TITLE DRS25A
CHECKED 25/May/2011 H. MAKI	名称 レーダーセンサー
APPROVED 25/May/2011 Y. NISHIYAMA	相互結線図
SCALE MASS kg	NAME RADAR SENSOR
DWG. No. C3573-C01-B	REF. No. 03-174-6003-4
INTERCONNECTION DIAGRAM	



# FURUNO Worldwide Warranty for Pleasure Boats (Except North America)

This warranty is valid for products manufactured by Furuno Electric Co. (hereafter FURUNO) and installed on a pleasure boat. Any web based purchases that are imported into other countries by anyone other than a FURUNO certified dealer may not comply with local standards. FURUNO strongly recommends against importing these products from international websites as the imported product may not work correctly and may interfere with other electronic devices. The imported product may also be in breach of the local laws and mandated technical requirements. Products imported into other countries as described previously shall not be eligible for local warranty service.

For products purchased outside of your country please contact the national distributor of Furuno products in the country where purchased.

This warranty is in addition to the customer's statutory legal rights.

## 1. Terms and Conditions of Warranty

FURUNO guarantees that each new FURUNO product is the result of quality materials and workmanship. The warranty is valid for a period of 2 years (24 months) from the date of the invoice, or the date of commissioning of the product by the installing certified dealer.

## 2. FURUNO Standard Warranty

The FURUNO standard warranty covers spare parts and labour costs associated with a warranty claim, provided that the product is returned to a FURUNO national distributor by prepaid carrier.

The FURUNO standard warranty includes:

- Repair at a FURUNO national distributor
- All spare parts for the repair
- Cost for economical shipment to customer

## 3. FURUNO Onboard Warranty

If the product was installed/commissioned and registered by a certified FURUNO dealer, the customer has the right to the onboard warranty.

The FURUNO onboard warranty includes

- Free shipping of the necessary parts
- Labour: Normal working hours only
- Travel time: Up to a maximum of two (2) hours
- Travel distance: Up to a maximum of one hundred and sixty (160) KM by car for the complete journey

## 4. Warranty Registration

For the Standard Warranty - presentation of product with serial number (8 digits serial number, 1234-5678) is sufficient. Otherwise, the invoice with serial number, name and stamp of the dealer and date of purchase is shown.

For the Onboard Warranty your FURUNO certified dealer will take care of all registrations.

## 5. Warranty Claims

For the Standard Warranty - simply send the defective product together with the invoice to a FURUNO national distributor. For the Onboard Warranty – contact a FURUNO national distributor or a certified dealer. Give the product's serial number and describe the problem as accurately as possible.

Warranty repairs carried out by companies/persons other than a FURUNO national distributor or a certified dealer is not covered by this warranty.

## 6. Warranty Limitations

When a claim is made, FURUNO has a right to choose whether to repair the product or replace it.

The FURUNO warranty is only valid if the product was correctly installed and used. Therefore, it is necessary for the customer to comply with the instructions in the handbook. Problems which result from not complying with the instruction manual are not covered by the warranty.

FURUNO is not liable for any damage caused to the vessel by using a FURUNO product.

The following are excluded from this warranty:

- a. Second-hand product
- b. Underwater unit such as transducer and hull unit
- c. Routine maintenance, alignment and calibration services.
- d. Replacement of consumable parts such as fuses, lamps, recording papers, drive belts, cables, protective covers and batteries.
- e. Magnetron and MIC with more than 1000 transmitting hours or older than 12 months, whichever comes first.
- f. Costs associated with the replacement of a transducer (e.g. Crane, docking or diver etc.).
- g. Sea trial, test and evaluation or other demonstrations.
- h. Products repaired or altered by anyone other than the FURUNO national distributor or an authorized dealer.
- i. Products on which the serial number is altered, defaced or removed.
- j. Problems resulting from an accident, negligence, misuse, improper installation, vandalism or water penetration.
- k. Damage resulting from a force majeure or other natural catastrophe or calamity.
- l. Damage from shipping or transit.
- m. Software updates, except when deemed necessary and warrantable by FURUNO.
- n. Overtime, extra labour outside of normal hours such as weekend/holiday, and travel costs above the 160 KM allowance
- o. Operator familiarization and orientation.

FURUNO Electric Company, March 1, 2011

## FURUNO Warranty for North America

FURUNO U.S.A., Limited Warranty provides a twenty-four (24) months LABOR and twenty-four (24) months PARTS warranty on products from the date of installation or purchase by the original owner. Products or components that are represented as being waterproof are guaranteed to be waterproof only for, and within the limits, of the warranty period stated above. The warranty start date may not exceed eighteen (18) months from the original date of purchase by dealer from Furuno USA and applies to new equipment installed and operated in accordance with Furuno USA's published instructions.

Magnetrons and Microwave devices will be warranted for a period of 12 months from date of original equipment installation.

Furuno U.S.A., Inc. warrants each new product to be of sound material and workmanship and through its authorized dealer will exchange any parts proven to be defective in material or workmanship under normal use at no charge for a period of 24 months from the date of installation or purchase.

Furuno U.S.A., Inc., through an authorized Furuno dealer will provide labor at no cost to replace defective parts, exclusive of routine maintenance or normal adjustments, for a period of 24 months from installation date provided the work is done by Furuno U.S.A., Inc. or an AUTHORIZED Furuno dealer during normal shop hours and within a radius of 50 miles of the shop location.

A suitable proof of purchase showing date of purchase, or installation certification must be available to Furuno U.S.A., Inc., or its authorized dealer at the time of request for warranty service.

This warranty is valid for installation of products manufactured by Furuno Electric Co. (hereafter FURUNO). Any purchases from brick and mortar or web-based resellers that are imported into other countries by anyone other than a FURUNO certified dealer, agent or subsidiary may not comply with local standards. FURUNO strongly recommends against importing these products from international websites or other resellers, as the imported product may not work correctly and may interfere with other electronic devices. The imported product may also be in breach of the local laws and mandated technical requirements. Products imported into other countries, as described previously, shall not be eligible for local warranty service.

For products purchased outside of your country please contact the national distributor of Furuno products in the country where purchased.

### WARRANTY REGISTRATION AND INFORMATION

To register your product for warranty, as well as see the complete warranty guidelines and limitations, please visit [www.furunousa.com](http://www.furunousa.com) and click on "Support". In order to expedite repairs, warranty service on Furuno equipment is provided through its authorized dealer network. If this is not possible or practical, please contact Furuno U.S.A., Inc. to arrange warranty service.

FURUNO U.S.A., INC.  
**Attention: Service Coordinator**  
4400 N.W. Pacific Rim Boulevard  
Camas, WA 98607-9408  
Telephone: (360) 834-9300  
FAX: (360) 834-9400

Furuno U.S.A., Inc. is proud to supply you with the highest quality in Marine Electronics. We know you had several choices when making your selection of equipment, and from everyone at Furuno we thank you. Furuno takes great pride in customer service.

## Declaration of Conformity



We **FURUNO ELECTRIC CO., LTD.**

(Manufacturer)

9-52 Ashihara-Cho, Nishinomiya City, 662-8580, Hyogo, Japan

(Address)

declare under our sole responsibility that the product

**NavNet 3D RADAR SENSOR DRS2D, DRS4D, DRS4A, DRS6A, DRS12A and DRS25A**

(Model name, type number)

are in conformity with the essential requirements as described in the Directive 1999/5/EC of the European Parliament and of the Council of 9 March 1999 on radio equipment and telecommunications terminal equipment (R&TTE Directive) and satisfies all the technical regulations applicable to the product within this Directive

IEC 60945 Ed.4.0: 2002 EMC related items

ITU-R M.1177-3: Spurious related items

IEC 60950-1 Ed.2.0: 2005 Safety related items

ITU-R SM.1539-1: Spurious related items

IEC 60950-1 Ed.2.0 A1: 2009 Safety related items

ITU-R SM.1541-2: Spurious related items

IEC 62252 Ed.1.0:2004(courses 4.33,5.33,Annex D)  
Spurious related item

ITU-R SM. 329-10: Spurious related items

(title and/or number and date of issue of the standard(s) or other normative document(s))

For assessment, see

- Statement of Opinion No.07214158 issued by Telefication, The Netherlands.

On behalf of Furuno Electric Co., Ltd.

Yoshitaka Shogaki  
Department General Manager  
Quality Assurance Department

Nishinomiya City, Japan  
December 7, 2011

(Place and date of issue)

(name and signature or equivalent marking of authorized person)



**ECF**  
(Elemental Chlorine Free)  
The paper used in this manual  
is elemental chlorine free.

**FURUNO ELECTRIC CO., LTD.**

9-52, Ashihara-cho,  
Nishinomiya, 662-8580, JAPAN

·FURUNO Authorized Distributor/Dealer

All rights reserved. Printed in Japan

A: JAN. 2008  
F: FEB. 7, 2013

Pub. No. IME-35670-F  
(REFU) DRS2D/4D/4A-25A



\* 00016745115 \*