

OWNER'S GUIDE & INSTALLATION INSTRUCTIONS

Thru-Hull: 1 kW with Temperature Sensor

Tilted Element™ Transducer
Tilt Angles: 0°, 12°, 20°

Models: B164, SS164

Chirp Models: B175H, B175HW, B175L, B175M,
SS175H, SS175HW, SS175L, SS175M

Pairs: SS264N & SS264W

Patent <http://www.airmar.com/patent.html>

07/19/18

17-455-01-rev. 12

Follow the precautions below for optimal product performance and to reduce the risk of property damage, personal injury, and/or death.

WARNING: Always install the two set screws with marine sealant applied to the threads. This will hold the hull nut firmly in place. Failure to do so may allow the hull nut to become loose.

WARNING: Always wear safety glasses, a dust mask, and ear protection when installing.

WARNING: Immediately check for leaks when the boat is placed in the water. Do not leave the boat unchecked for more than three hours. Even a small leak may allow considerable water to accumulate.

WARNING: Stainless steel housing in a metal hull—Be sure the washer contacts the hull. Do not tighten the hull nut with the washer against the isolation bushing, as the housing will not be firmly installed. If necessary, sand the isolation bushing until the washer rests against the hull.

CAUTION: Chirp transducer—Do not install in the engine compartment or other hot place. The transducer may fail if it overheats.

CAUTION: Chirp transducer—Always operate the transducer in water. Operating in air will allow the transducer to overheat resulting in failure.

CAUTION: The arrow on the top of the transducer must point toward the keel or centerline of the boat. This will align the angle of the element inside the transducer with the deadrise angle of your hull.

CAUTION: Never install a metal transducer on a vessel with a positive ground system.

CAUTION: Never pull, carry, or hold the transducer by its cable; this may sever internal connections.

CAUTION: Stainless steel housing in a metal hull—Stainless steel housing must be isolated from a metal hull to prevent electrolytic corrosion. Use the isolation bushing supplied.

CAUTION: Never use solvents. Cleaner, fuel, sealant, paint, and other products may contain solvents that can damage plastic parts, especially the transducer's face.

IMPORTANT: For optimal performance, apply marine sealant to the entire inside surface of the spacer. This will fill the gap between the spacer and the sidewall of the transducer preventing vibration.

Record the information found on the cable tag for future reference.

Part No. _____ Date _____ Frequency _____ kHz

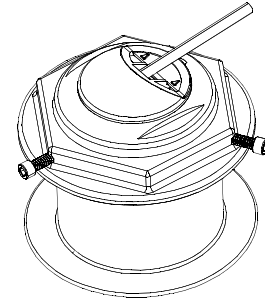

IMPORTANT: Read the instructions completely before proceeding with the installation. These instructions supersede any other instructions in your instrument manual if they differ.

Applications

- **Bronze** housing recommended for fiberglass or wood hulls. *Never install a bronze housing in an aluminum hull, because electrolytic corrosion will occur.*
- **Stainless steel** housing compatible with all hull materials. Recommended for metal hulls to prevent electrolytic corrosion *provided the stainless steel housing is isolated from the metal hull.*

Match Tilt Angle of Transducer to Deadrise

Be sure your transducer model matches the deadrise angle of your hull at the selected mounting location. The tilt angle is printed on the top of the transducer (Figure 1). To measure the deadrise angle of your hull at the selected mounting location, use an angle finder or a digital level (Figure 2).

- 0° transducer for deadrise angles from 0° to 7°
- 12° transducer for deadrise angles from 8° to 15°
- 20° transducer for deadrise angles from 16° to 24°

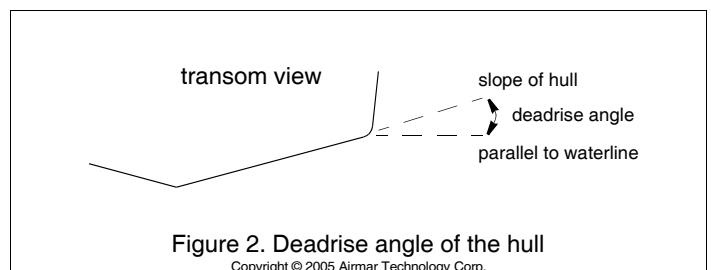
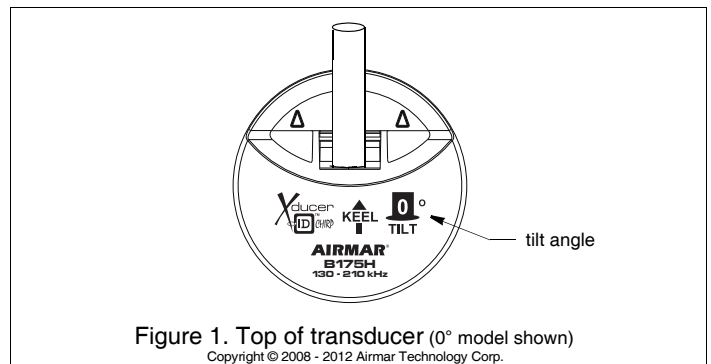

Tools & Materials

Safety glasses
 Dust mask
 Ear protection
 Angle finder
 Electric drill with 10mm (3/8") or larger chuck capacity
 Drill bit: 3mm or 1/8"
 Hole saw: 95mm or 3-3/4" (fiberglass or wood hull)
 105mm or 4-1/8" (metal hull)
 Grinder (some installations)
 Sandpaper
 Mild household detergent or weak solvent (such as alcohol)
 File (installation in a metal hull)
 Marine sealant (suitable for below waterline)
 Allen wrench: 3/16"
 Slip-joint pliers
 Grommet(s) (some installations)
 Cable ties
 Water-based anti-fouling paint (**mandatory in salt water**)
 Installation in a cored fiberglass hull (page 4):
 Hole saw for hull interior: 115mm or 4-1/2"
 Fiberglass cloth and resin
 or Cylinder, wax, tape, and casting epoxy

Mounting Location

CAUTION: Do not mount in line with or near water intake or discharge openings, or behind strakes, fittings, or hull irregularities that will disturb the water flow.

- The water flowing under the hull must be smooth with a minimum of bubbles and turbulence (especially at high speeds).
- The transducer must be continuously immersed in water.
- The transducer beam must be unobstructed by the keel or propeller shaft(s).
- Choose a location away from interference caused by power and radiation sources such as: the propeller(s) and shaft(s), other machinery, other echosounders, and other cables. The lower the noise level, the higher the echosounder gain setting that can be used.
- Choose an accessible spot inside the vessel with a minimum of 178 mm (7") of space for the height of the housing, installing the spacer, and tightening the nut and set screws.
- **Chirp transducer**—Mount in a cool well-ventilated area away from the engine to avoid overheating.
- **Pairs**—Mount the transducers across from one another on opposite sides of the centerline (keel) (Figure 4).

Boat Types (Figure 3)

Planing hull powerboats—Mount well aft, near the centerline, and *well inboard* of the first set of lifting strakes to ensure that the transducer will be in contact with the water at high speeds. The

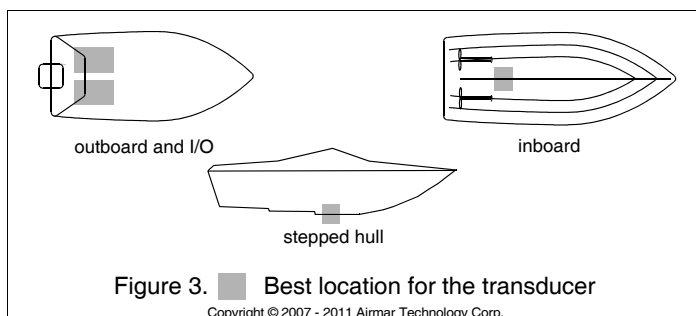

starboard side of the hull where the propeller blades are moving downward is preferred.

- **Outboard and I/O**—Mount just forward of the engine(s).
- **Inboard**—Mount well ahead of the propeller(s) and shaft(s).
- **Stepped hull**—Mount just ahead of the first step.
- **Boat capable of speeds above 25kn (29MPH)**—Review the installation location and operating results of similar boats before proceeding.

Installation

Hole Drilling & Dry Fitting

Cored fiberglass hull—Follow separate instructions on page 4.

1. From inside the hull, using the hull nut as a guide to ensure ample space, mark the center point. Then drill a 3mm or 1/8" pilot hole. If there is a rib, strut, or other hull irregularity near the selected mounting location, drill from the outside.
2. Using a 95mm or 3-3/4" hole saw, cut a hole from outside of the hull perpendicular to the hull surface. It may be necessary to enlarge the hole slightly using a grinder or file.

Stainless steel housing in a metal hull—Use a 105mm or 4-1/8" hole saw to accommodate the isolation bushing. It may be necessary to enlarge the hole slightly using a grinder or file.

3. Sand and clean the area around the hole, inside and outside, to ensure that the sealant will adhere properly to the hull. If there is any petroleum residue inside the hull, remove it with either mild household detergent or a weak solvent (alcohol) before sanding.

Metal hull—Remove all burrs with a file and sandpaper.

4. Dry fit the transducer to determine if the spacer must be cut. From outside the hull, push the housing through the mounting hole (Figure 5). From inside, slide one of the washers onto the housing. Slide the spacer onto the housing with the open end facing the hull. Add the remaining washer. *Be sure a minimum of **THREE** threads are showing on the housing above the washer.* If not, cut the spacer to make it shorter. When cutting the spacer, *be sure to cut the open end* (Figure 6).

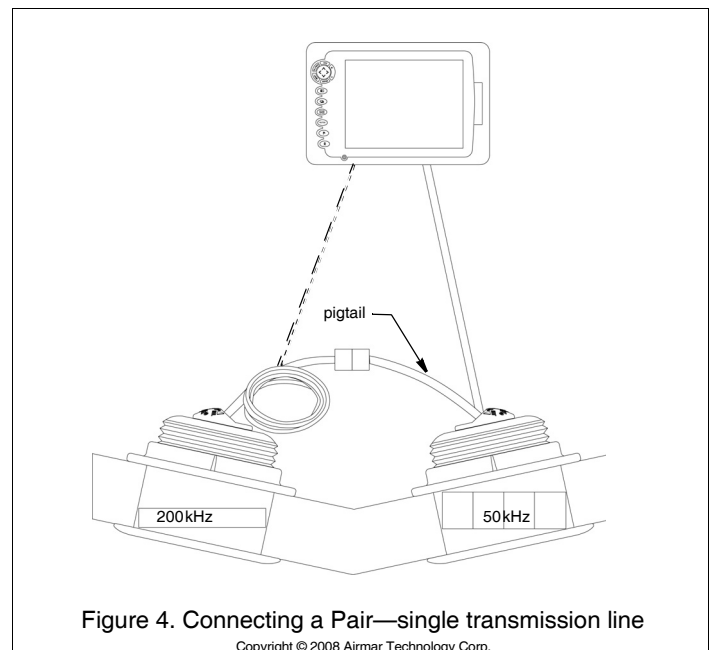

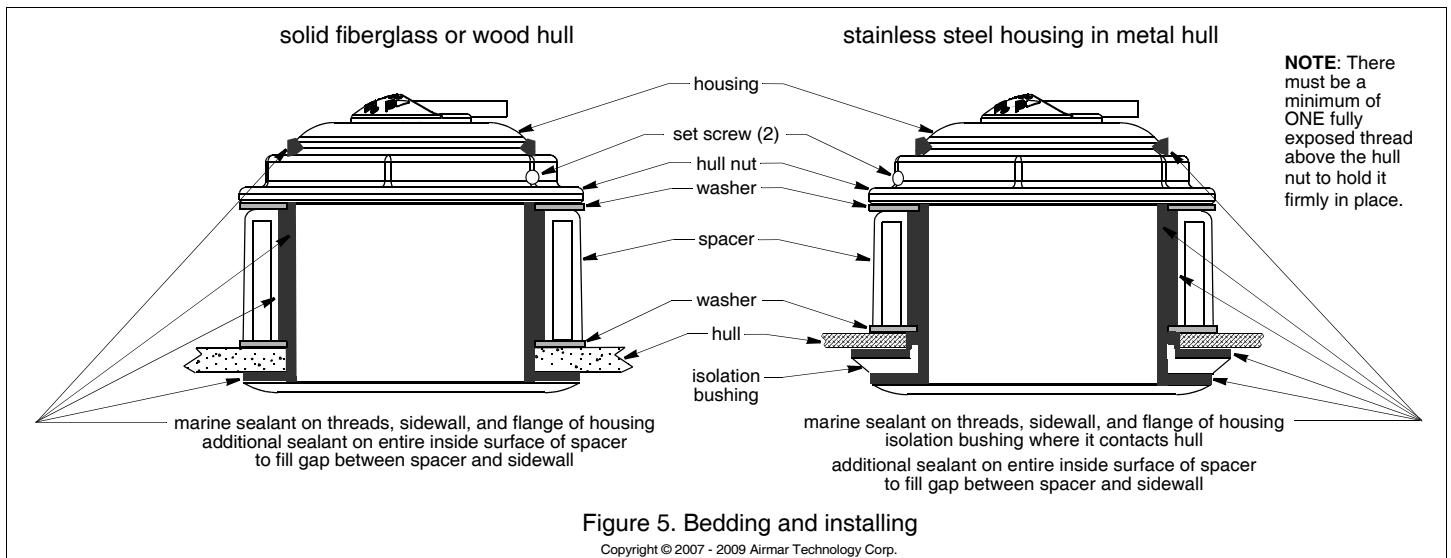

Figure 5. Bedding and installing

Copyright © 2007 - 2009 Airmar Technology Corp.

Bedding

CAUTION: Be sure the surfaces to be bedded are clean and dry.

1. Apply a 4 mm (1/8") thick layer of marine sealant to the flange, sidewall, and threads of the housing (Figure 5). The sealant must extend 12 mm (1/2") higher than the combined thickness of the hull, spacer, and hull nut. This will ensure there is marine sealant in the threads to seal the hull and to hold the hull nut securely in place.

Stainless steel housing in a metal hull—To prevent electrolytic corrosion, the stainless steel housing must be isolated from the metal hull. Slide the isolation bushing onto the housing. Apply *additional marine sealant* to the surfaces of the bushing that will contact the hull, filling any cavities in and around the bushing.

2. Apply a 4 mm (1/8") thick layer of marine sealant to the entire inside surface of the spacer. This will fill the gap between the spacer and the sidewall of the transducer preventing vibration.

Installing

1. From outside the hull, thread the cable through the mounting hole. Push the housing into the mounting hole using a twisting motion to squeeze out excess sealant.

12° and 20° models—From inside the hull, point the arrow on the top of the transducer (and the cable exit) toward the KEEL or centerline of the boat (Figure 1). This will align the angle of the element inside the transducer with the deadrise angle of your hull.

2. From inside the hull, slide one of the washers onto the housing (Figure 5). Slide the spacer onto the housing until the open end rests against the washer. Add the remaining washer. **Be sure a minimum of THREE threads are showing on the housing above the washer.** If not, make the spacer shorter by cutting the open end (Figure 6).

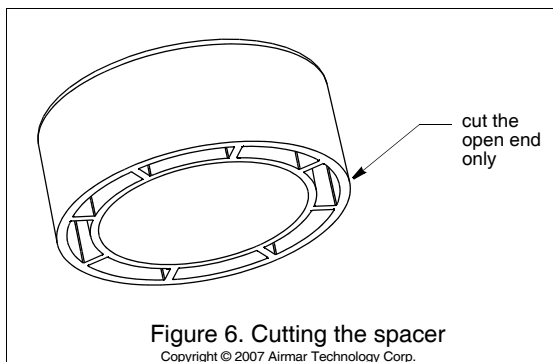

Figure 6. Cutting the spacer

Copyright © 2007 Airmar Technology Corp.

3. Screw the hull nut in place using slip-joint pliers. **Be sure a minimum of ONE full thread is exposed above the hull nut.**

Cored fiberglass hull—Do not over tighten, crushing the hull.

Wood hull—Allow the wood to swell before tightening the hull nut.

4. **Secure the hull nut with the two set screws supplied** (Figure 7). Apply marine sealant to the threads of the set screws. Using an Allen wrench, tighten each set screw until it makes contact with the housing threads. Continue to tighten an additional 1/8 to 1/4 turn. This will hold the hull nut firmly in place. *Failure to do so may allow the hull nut to vibrate loose.*
5. Remove any excess marine sealant on the outside of the hull to ensure smooth water flow under the transducer.

Cable Routing & Connecting

CAUTION: If the transducer came with a connector, do not remove it to ease cable routing. If the cable must be cut and spliced, use Airmar's splash-proof Junction Box No. 33-035 and follow the instructions supplied. Removing the waterproof connector or cutting the cable, except when using a water-tight junction box, will void the sensor warranty.

1. Route the cable to the instrument, being careful not to tear the cable jacket when passing it through the bulkhead(s) and other parts of the boat. Use grommet(s) to prevent chafing. To reduce electrical interference, separate the transducer cable from other electrical wiring and the engine. Coil any excess cable and secure it in place using cable ties to prevent damage.
2. Refer to the echosounder owner's manual to connect the transducer to the instrument.

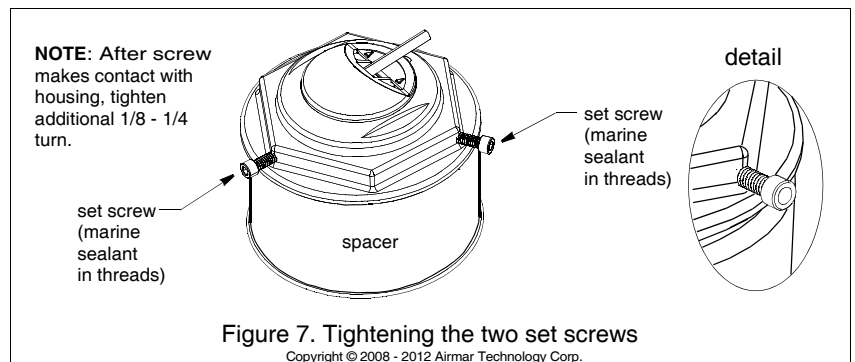
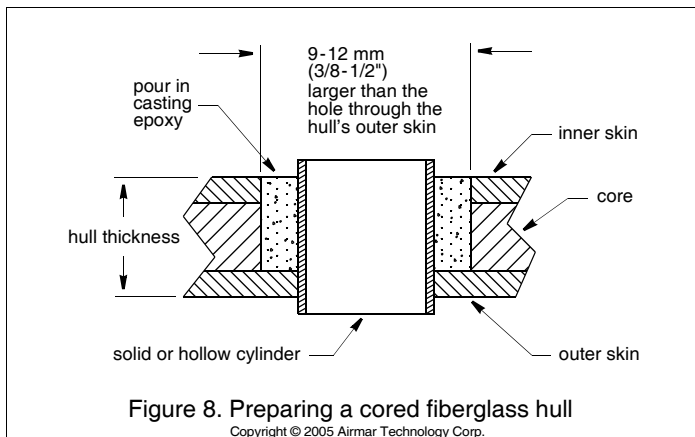

Figure 7. Tightening the two set screws

Copyright © 2008 - 2012 Airmar Technology Corp.



4. Remove the plug of core material, so the *inside* of the outer skin and the inner core of the hull is fully exposed. Sand and clean the inner skin, core, and the outer skin around the hole.
5. If you are skilled with fiberglass, saturate a layer of fiberglass cloth with a suitable resin and lay it inside the hole to seal and strengthen the core. Add layers until the hole is the correct diameter.

Alternatively, a hollow or solid cylinder of the correct diameter can be coated with wax and taped in place. Fill the gap between the cylinder and hull with casting epoxy. After the epoxy has set, remove the cylinder.
6. Sand and clean the area around the hole, inside and outside, to ensure that the marine sealant will adhere properly to the hull. If there is any petroleum residue inside the hull, remove it with either mild household detergent or a weak solvent (alcohol) before sanding.
7. Proceed with "Bedding" (page 3).

Maintenance, Parts & Replacement

Anti-fouling Paint

Surfaces exposed to salt water must be coated with anti-fouling paint. *Use water-based anti-fouling paint only.* Never use ketone-based paint, since ketones can attack many plastics possibly damaging the transducer. Reapply anti-fouling paint every 6 months or at the beginning of each boating season.

Cleaning

Aquatic growth can accumulate rapidly on the transducer's face, reducing its performance within weeks. Clean the surface with a Scotch-Brite® scour pad and mild household detergent, *being careful to avoid making scratches.* If the fouling is severe, lightly wet sand it with fine grade wet/dry paper.

Replacement Transducer & Parts

The information needed to order a replacement transducer is printed on the cable tag. Do not remove this tag. When ordering, specify the part number, date, and frequency in kHz. For convenient reference, record this information on the top of page one.

Lost, broken, and worn parts should be replaced immediately. Obtain parts from your instrument manufacturer or marine dealer.

Gemeco

USA

Tel: 803-693-0777

email: sales@gemeco.com

Airmar EMEA

Europe, Middle East, Africa

Tel: +33.(0)2.23.52.06.48

email: sales@airmar-emea.com



Pairs

- **Single transmission line fishfinder**—Connect the 10m (33') cable of the 200kHz transducer to the 1m (3') pigtail of the 50kHz transducer. Connect the remaining 10m (33') cable to the fishfinder (Figure 4).
- **Dual transmission line fishfinder**—Do not use the pigtail on the 50kHz transducer. Fasten it to the main cable with a cable tie. Connect the 10m (33') cable of the 50kHz transducer to the low-frequency (50kHz) input on the fishfinder and the 200kHz transducer cable to the high-frequency (200kHz) input.

Checking for Leaks

When the boat is placed in the water, **immediately** check around the transducer for leaks. Note that very small leaks may not be readily observed. Do not leave the boat in the water for more than 3 hours before checking it again. If there is a small leak, there may be considerable bilge water accumulation after 24 hours. If a leak is observed, repeat "Bedding" and "Installing" **immediately** (page 3).

Installation in a Cored Fiberglass Hull

The core (wood or foam) must be cut and sealed carefully. The core must be protected from water seepage, and the hull must be reinforced to prevent it from crushing under the hull nut allowing the housing to become loose.

CAUTION: Completely seal the hull to prevent water seepage into the core.

1. Drill a 3mm or 1/8" pilot hole from inside the hull. If there is a rib, strut, or other hull irregularity near the selected mounting location, drill from the outside. (If the hole is drilled in the wrong location, drill a second hole in a better location. Apply masking tape to the outside of the hull over the incorrect hole and fill it with epoxy.)
2. Using the 95mm or 3-3/4" hole saw, cut a hole from outside the hull through the *outer* skin only (Figure 8). It may be necessary to enlarge the hole slightly using a grinder.
3. From inside the hull, using the 115mm or 4-1/2" *hull interior* hole saw, cut through the *inner* skin and most of the core. The core material can be very soft. Apply only light pressure to the hole saw after cutting through the *inner* skin to avoid accidentally cutting the *outer* skin.



35 Meadowbrook Drive, Milford, New Hampshire 03055-4613, USA

•www.airmar.com