

M-10830 1

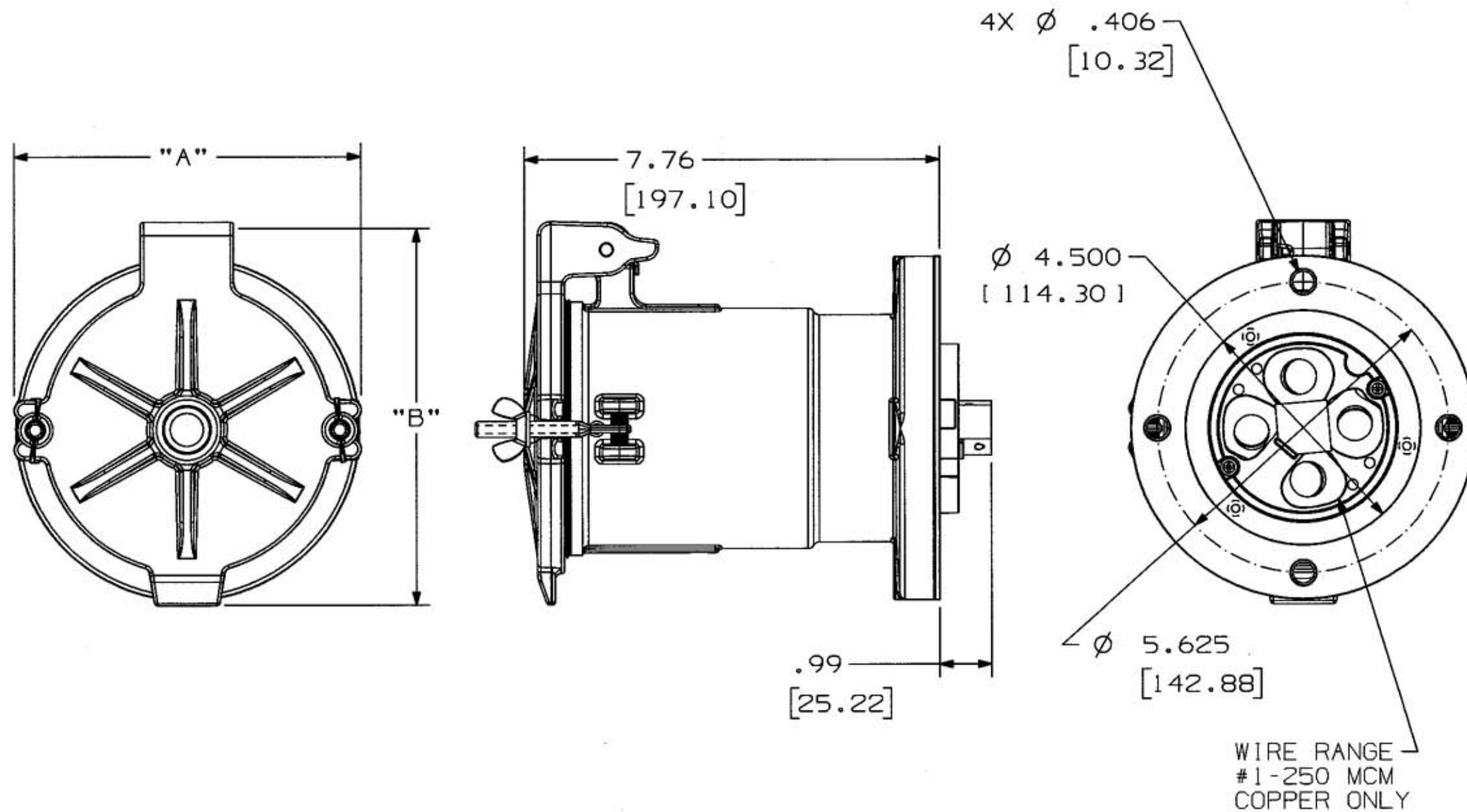

NOTES: (UNLESS OTHERWISE SPECIFIED)

1) DIMENSION FORMAT IS: INCHES [mm]

TABLE

AMPS	MAX VOLTAGE AC/DC	CONNECTOR CATALOG NUMBER	PLUG			DIM "A"		DIM "B" Ø	
			STYLE	POLE	WIRE	INS.	mm	INS.	mm
200	600/250	M5200RS1	S1	4P	5W	6.9	169.9	7.39	187.7

LIST OF PARTS

DESCRIPTION	MATERIAL	FINISH
HINGE BUSHING	ALUMINUM	
SPRING GUIDE	STAIN STEEL	
LID SPRING	STAIN STEEL	
LID	ALUMINUM	GRAY EPOXY
O-RING	RUBBER	
LID GASKET	RUBBER	
RIVET	ALUMINUM	
RECEPTACLE	ALUMINUM	GRAY EPOXY
SCREWS	STAIN STEEL	
PIN SPRING	COPPER ALLOY	SILVER COATED
SPRING WASHER	COPPER ALLOY	
PINS	COPPER ALLOY	NICKEL PLATED
SWING BOLT	STAIN STEEL	
BUTTERFLY NUT	STAIN STEEL	
GROUND POST	BRASS	
GROUND STRAP	COPPER ALLOY	
INTERIOR	THERMOSET POLYESTER	

REPAIRABLE <input checked="" type="checkbox"/>	NON-REPAIRABLE <input type="checkbox"/>
--	---

1	RELEASED PER DCN #14472 JMN	WUH W/H	1/31/08
SYM	REVISIONS	APP	DATE

THE DESIGN AND DIMENSIONS OF THE PRODUCT SHOWN ON THIS DRAWING ARE SUBJECT TO CHANGE WITHOUT NOTICE

TITLE
200A MARINE INSULGRIP
PIN & SLEEVE RECEPTACLE
STYLE 1

TOLERANCES UNLESS OTHERWISE SPECIFIED FRACTIONS ±1/64 DECIMALS ±.005 ANGLES ±2° 2 DECIMALS ±.030	WIRING DEVICE-KELLEMS HUBBELL INCORPORATED BRIDGEPORT, CT	
	DR. BY JMN	APP. BY WUH
	TR. BY	SCALE 1:2
	CHK'D BY WUH	DATE 1/31/08

DIMENSION SHEET FOR CAT. NO. SEE TABLE
REPAIRABLE NON-REPAIRABLE B M-10830 1