



KOOLAIR PUMPS
MANUFACTURER'S EDGE
5044 INDUSTRIAL RD, SUITE C
FARMINGDALE, NJ 07727
P: 800-810-1053 E: INFO@KOOLAIR.COM

“RUN DRY PROTECTION TO KEEP YOU COOL”

MARINE COOLANT PUMPS

DESCRIPTION:

The PM500 is magnetically driven pump, with no shaft seal. The pump is epoxy encapsulated, which allows the PM pump to run fully submerged in many liquids or in open air for complete moisture protection. When re-assembling the pump for service, make sure all “O” Rings are properly seated. See the repair parts list for a breakdown of replacement parts.

OPERATION:

The pump is not self-priming and requires a suction. The pump has run dry and thermal overload protection. In a run dry situation the pump will shut down. Simply let it cool down or hose it down to assist in the cooling.

For application assistance contact Koolair Pump at: info@koolairpump.com

ELECTRICAL:

PM500 is 115 & 230 Volt. 1 Phase. All cords are 6 feet in length and are U.L. LISTED 18/3 wire. The motors are rated as continuous duty.

LIMITED WARRANTY:

Koolair Pumps are guaranteed only against defects in workmanship or materials for a period of one year from date of manufacture while pumping water.

NOTES:

All Specifications and flow curves are based on pumping water.



PM500-1
PM500-2

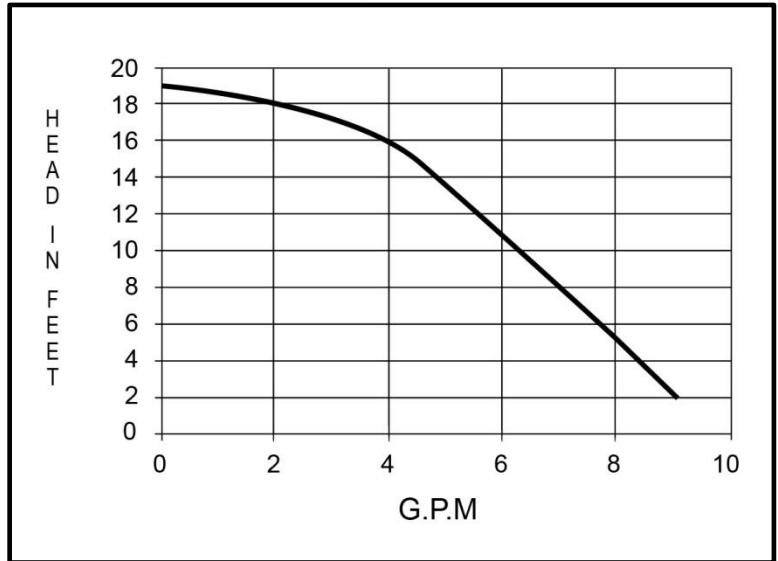

MECHANICAL SPECIFICATIONS

MODULE TYPE		60Hz	50Hz
Max Flow	GPM	8.5	N/A
	LPM	N/A	31
Max Head	FT (PSI)	19 (8.2)	N/A
	M	N/A	4.3
Max Internal Pressure	PSI	25	25
	BAR	1.7	1.7
Max Liquid Temperature	°F	130	130
	°C	54	54
Packed Weight	LB	8.5	8.5
	KG	3.85	3.85
Inlet		3/4" FPT	3/4" FPT
Outlet		1/2" MPT	1/2" MPT

ELECTRICAL SPECIFICATIONS

MODULE TYPE	60Hz		50Hz	
Voltage	115	230	115	230
Phase	1	1	1	1
Watts	120	120	137	100
Amps	2.0	1.0	2.3	1.0
HP/kW	1/20	1/20	0.037	0.037
RPM	3450	3450	2850	2850

PUMP DIMENSIONS	INCHES	CENTIMETERS
Height	4.87	12.3
Width	4.80	12.2
Length	7.50	19.0

PARTS LIST

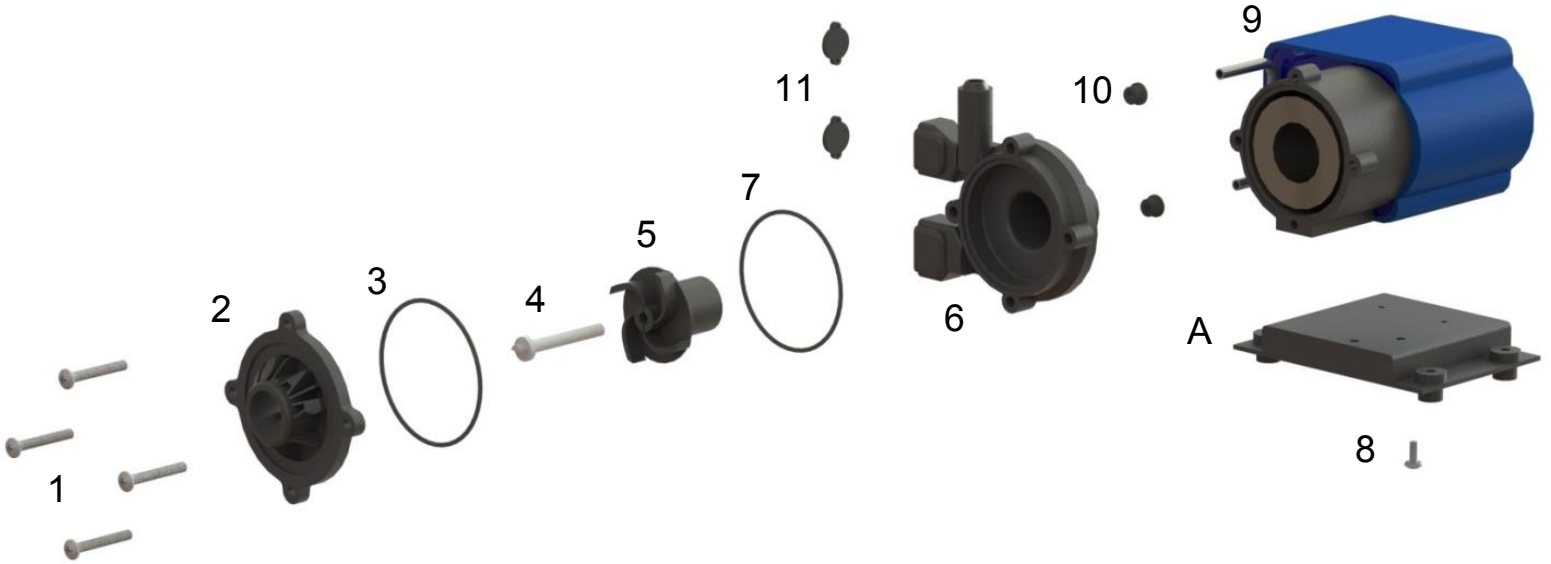

ITEM	PART NUMBER	DESCRIPTION	MATERIAL	LENGTH		WIDTH	
				CM	MM	CM	MM
1	KA500-21	Screw	Stainless Steel	3.7	37	0.5	5
2	KA500-22	Front Cover	Reinforced PP	10	100	3.4	34
3	KA500-23	O-Ring	Silicon	6.84	68.4	0.26	2.6
4	KA500-24	Washer & Shaft	Ceramic	5.9	59	4.5	45
5	KA500-25	Impeller	Interior-Carbon Bush Exterior-Reinforced PP	1.015	10.15	1.015	10.15
6	KA500-26	Rear Housing	Stainless Steel	7.2	72	0.25	2.5
7	KA500-27	O-Ring	Rubber	1.2	12	0.5	5
8	KA500-28	Screw	Stainless Steel				
9	KA500-29	Driver Magnet & Epoxy Motor	Ferrite Ceramic				
10	KA500-30	Grommet	Rubber	ID: 0.6 cm or 6 mm		OD: 1.05 cm or 105 mm	
11	KA500-31	Front Housing Cover	Reinforced PP				
A	KA500-32	Base	Reinforced PP	8.128	81.28	10.795	107.95
B	KA500-33	Optional Base	Reinforced PP				

PUMP DRAWING

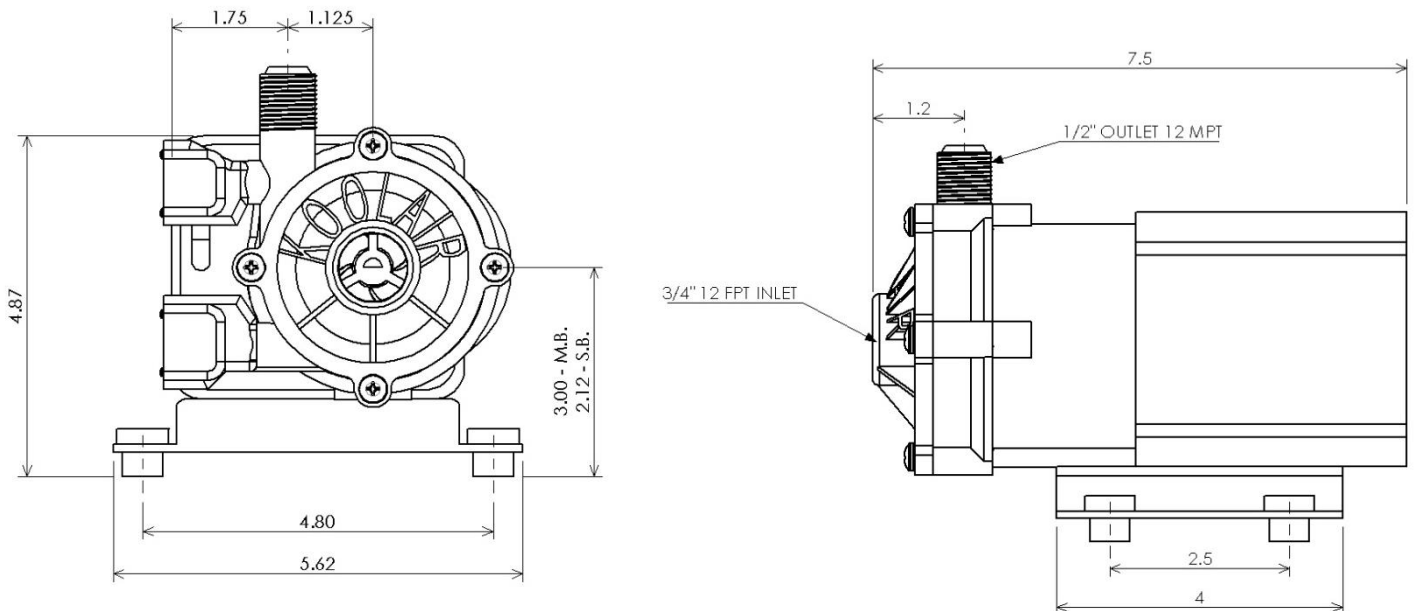

3D MODEL

You Must Download & Open PDF In Adobe Reader To Enable 3D View



Enable 3D View

Click on image and move your mouse to turn and rotate 3D model.
You can also zoom in and out using the scroll wheel on your mouse.