



Auto Glide™

Boat Control System

Owner's Manual A

Installation & Setup

Procedures



Please visit our website to view up-to-date information and various videos which may be beneficial to you. www.lencoautoglide.com

TABLE OF CONTENTS

1.0 PRODUCT OVERVIEW *...3-4*

1.1 System Requirements *...4*

2.0 AUTO GLIDE™ MECHANICAL INSTALLATION *...5-6*

2.1 Auto Glide™ Key Pad Installation *...5*

2.2 Replacing Existing 123 LED Indicator / 124 Standard Key Pad *...5*

2.3 Auto Glide™ Control Box Installation *...6*

2.4 Optional Auto Glide™ Control Box Mounting Bracket Installation *...6*

2.5 Replacing Existing 123 / 123DR LED Indicator / 124 Standard Control Box *...6*

3.0 AUTO GLIDE™ ELECTRICAL INSTALLATION *...7-11*

3.1 Auto Glide™ Control Box Harnesses Overview *...7*

3.2 Auto Glide™ Control Box Harness Installation *...8*

3.3 Battery Switch Requirements *...9*

3.4 Optional GPS (Stand Alone) Antenna Installation *...9-10*

3.5 Optional Auto Glide™ GPS Mounting Bracket *...11*

3.6 Auto Glide™ Second Station Kit Installation *...11*

4.0 AUTO GLIDE™ INSTALLATION VERIFICATION *...12-14*

4.1 Auto Glide™ Test Mode *...12*

4.2 Testing The Trim Tab Actuators *...12*

4.3 CANBUS Data Verification *...13-14*

4.4 Exiting Test Mode *...14*

5.0 HOME ROLL AND HOME PITCH SETUP INSTRUCTIONS *...15-19*

5.1 Home Roll and Home Pitch Overview *...15*

5.2 Home Roll Setup *...15-17*

5.3 Home Pitch Setup *...17-19*

6.0 RESETTING HOME ROLL AND HOME PITCH DEFAULT POSITIONS *...20-22*

6.1 Resetting Home Pitch Only *...20-21*

6.2 Resetting Home Roll and Pitch *...21-22*



Auto Glide™ System Product Overview

CONGRATULATIONS! You have just purchased the most advanced automatic trim tab control system. Welcome to the future!

The Auto Glide Boat Control System is the first genuine fully automatic trim tab control system in the world. The Auto Glide System uses unsurpassed technology to monitor the boats speed and position, and automatically adjusts the trim tabs position to accommodate any boating condition to provide a smoother, more comfortable ride. This allows that boat operator to run the boat the way it was designed to perform.

- Fuel savings! GPH savings are recognized due to the boat running at it's most efficient planing angle.
- Safety - better visibility due to improved hole shot mode and running angle and safer due to the fact that you can focus your attention on boating matters other than the trim tabs.

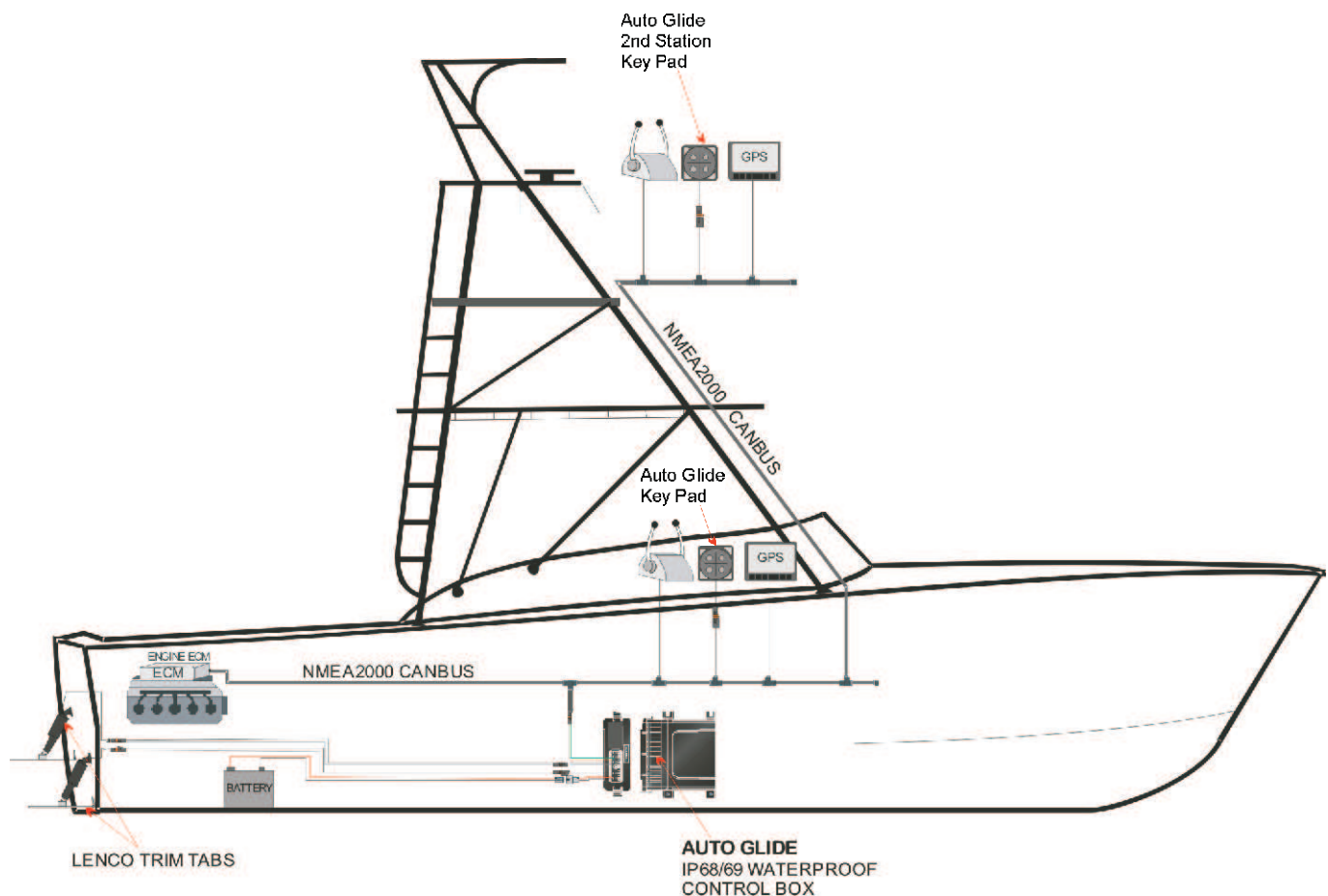



WARNING



CAUTION

IMPORTANT INSTRUCTIONS AND FACTS ABOUT YOUR NEW AUTO GLIDE BOAT CONTROL SYSTEM

- ** PLEASE READ ALL OF THE INSTALLATION INSTRUCTIONS IN THIS MANUAL BEFORE PROCEEDING. YOU WILL NEED TO PRINT OUT YOUR APPLICABLE WIRING SCHEMATIC / DRAWING / PARTS LIST FROM OUR WEBSITE BEFORE YOU BEGIN THE INSTALLATION PROCESS.
- ** YOU MUST PERFORM ALL OF THE SET UP FUNCTIONS AFTER THE PROPER INSTALLATION OF BUT BEFORE USING YOUR AUTO GLIDE SYSTEM
- ** YOU ARE RESPONSIBLE FOR:
 - (A) DETERMINING THAT YOUR SYSTEM IS A CANBUS BASED SYSTEM
 - (B) CONNECTING OUR NMEA 2000 CABLE TO ENGINE(S) (YOU MAY HAVE TO CONTACT THE ENGINE MANUFACTURER)
 - (C) CONNECTING OUR CAN 2 CABLE TO A GPS NETWORK (IF APPLICABLE) (YOU MAY HAVE TO CONTACT THE GPS MANUFACTURER)

1.1 System Requirements

- Boat **must have** CANbus based engine(s) (see list below)
- Boat **must have** NMEA 2000 GPS network or NMEA 2000 antenna receiver. NMEA 0183 will work, but will have slower signal response. Lenco offers a NMEA 2000 GPS antenna receiver and optional stainless steel mounting bracket.
- Boat **must have** Lenco Single or Dual Trim Tab System with Lenco Electric Actuators

Available for these CANBUS-based engines:

NMEA2000 Engines

- Yamaha
(Command Link Plus requires NMEA 2000
Yamaha Gateway P/N:6Y98A2D00000)
- Evinrude
- Honda
- Suzuki
- Volvo Penta (EVC Engines)
(With a Volvo NMEA2000 Gateway - Volvo P/N
3889757)

SmartCraft Engines

- Mercury - Verado
- Mercury - Optimax with SmartCraft ECU
- Mercruiser with SmartCraft ECU
- Cummins/Mercruiser w/ SmartCraft ECU

J1939 Engines

- Volvo Penta (Non-EVC Engines)
- Yanmar
- Caterpillar
- Cummins
- Detroit Diesel
- John Deere
- Steyr



WARNING

Before cutting, make sure the inside the area inside the helm is clear of wires and other equipment that could be damaged.



CAUTION

Please read through the instructions in their entirety prior to beginning installation! Proper function of this product cannot be assured unless you follow these instructions.

2.1 Auto Glide™ Key Pad Installation

- ① Determine where the Auto Glide™ key pad will be installed. Must have a 2.75" by 2.75" clearance on helm.
- ② Before cutting, make sure the area inside the helm is clear of wires and other equipment that could be damaged. Find center of key pad location and cut a circular opening using a 2" (5.08cm) hole saw (**hole must be 2" (5.08cm)**).
- ③ Drop key pad into 2" (5.08cm) hole.
- ④ From underneath the helm, hand tighten the large white key pad nut onto the back of the key pad. Make sure the key pad is securely installed. (See Figure 2.1.1) Note: key pad nut can be flipped to accommodate helm thickness.

Figure 2.1.1

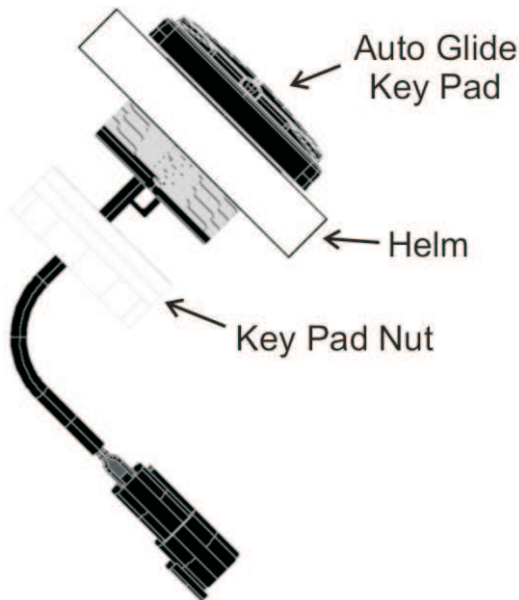

Figure 2.1.2



2.2 Replacing Existing 123 LED Indicator / 124 Standard Key Pad

- ① From underneath the helm, disconnect the existing key pad from the control box. Squeeze the release mechanism on the black wire and pull it away from the existing key pad.
- ② Unscrew the four nylon nuts from the existing key pad posts.
- ③ From the top side of the helm, remove existing key pad.
- ④ Install the Auto Glide™ key pad by simply dropping it into the existing 2" (5.08cm) hole and screw the large white key pad nut onto the back of the key pad. Make sure the key pad is securely installed.



WARNING

Before drilling, make sure the mounting hardware will not damage any existing wiring, structures, or hoses. **DO NOT CONNECT TO POWER AT THIS TIME.**



CAUTION

Please read through the instructions in their entirety prior to beginning installation! Proper function of this product cannot be assured unless you follow these instructions.

2.3 Auto Glide™ Control Box Installation

Determine where the Auto Glide™ control box will be installed.

- **MUST BE INSTALLED ON A VERTICAL SURFACE WITH THE CONNECTOR FACING STERN (REAR OF THE BOAT)! The top of the control box (sticker side) can face either port (left) or starboard (right). If a port or starboard vertical surface is not accessible, an optional Auto Glide™ control box mounting bracket is available. (See section 2.4 below.)**
- Install level. A 15° (+/-) tolerance in all directions is allowed. (See Figure 2.3.1)
- Install within 4' (1.21m) of the Auto Glide™ Key Pad. (If key pad must be installed further than 4' use a CANBUS Extension Cable 30260-XXX Series. See price list for different lengths.)
- Control box mounting hardware to be supplied by customer.

NOTE: DO NOT CONNECT POWER TO AUTO GLIDE CONTROL BOX AT THIS TIME

Figure 2.3.1

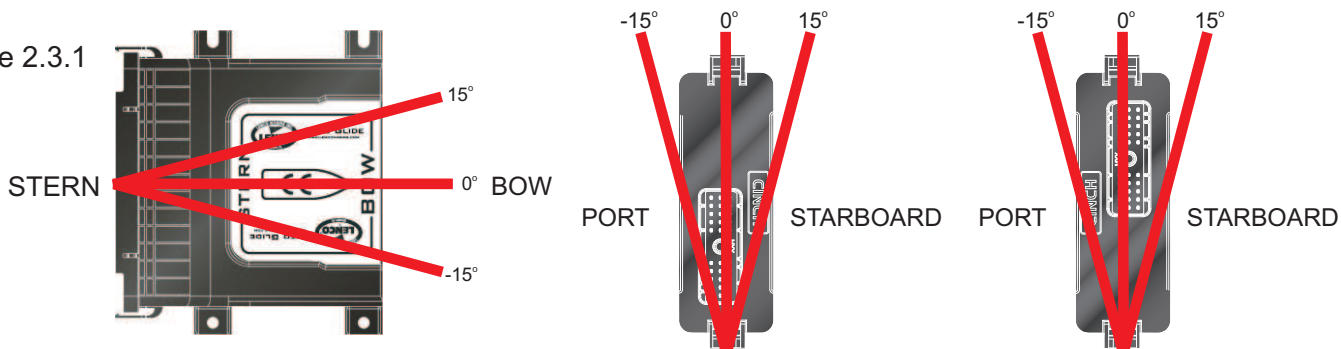

2.4 Optional Auto Glide™ Control Box Mounting Bracket Installation

Determine where the optional Auto Glide™ control box mounting bracket (Part # 70568-001) will be installed.

- **L SHAPE MUST BE INSTALLED FACING EITHER PORT (LEFT) OR STARBOARD (RIGHT)! THE CONTROL BOX MUST BE MOUNTED WITH THE CONNECTOR FACING STERN (REAR OF THE BOAT)! Top of the control box (sticker side) can face either port or starboard. (See Figure 2.4.2 for some installation examples)**
- Install level with the boat. A 15° (+/-) tolerance in all directions is allowed. (See Figure 2.3.1)
- Install within 4' (1.21m) of the Auto Glide™ key pad.
- Mounting bracket & control box mounting hardware included.

Figure 2.4.1

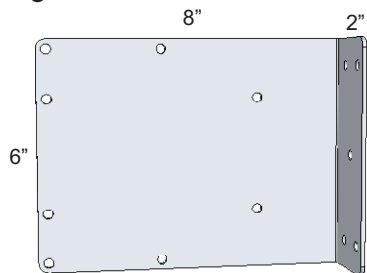
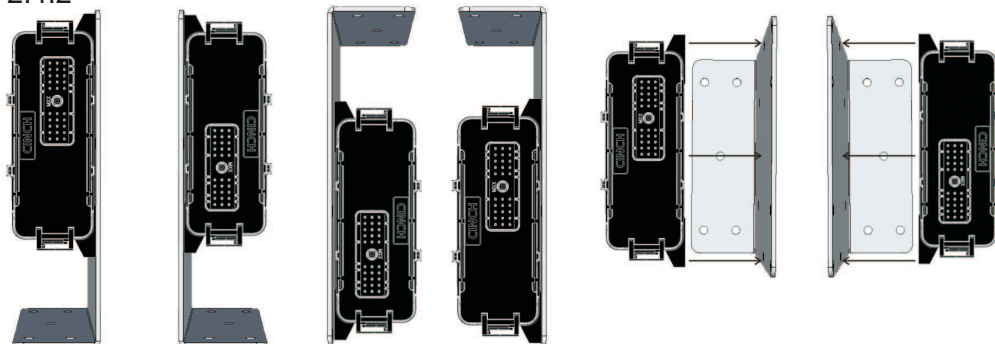

Figure 2.4.2



2.5 Replacing Existing 123 / 123DR LED Indicator / 124 Standard Control Box

To remove existing control box:

- Disconnect control box from power.
- Disconnect control box from actuators.
- Disconnect control box orange wire from tach or mechanical on / off switch.
- Remove two mounting screws and remove box from boat.
- See section 2.3 above for Auto Glide Control Box installation instructions.



WARNING

The power connections should always be the last connection made.
Power connections should only be made while the battery switch in the OFF position.



CAUTION

Please read through the instructions in their entirety prior to beginning installation! Proper function of this product cannot be assured unless you follow these instructions.

3.1 Auto Glide™ Control Box Harness Overview

There are two types of Auto Glide™ Control Box Harnesses:

- Single Actuator Auto Glide™ Control Box Harness for systems with two actuators (See Figure 3.1.1)
- Dual Actuator Auto Glide™ Control Box Harness for systems with four actuators (See Figure 3.1.2)

Each Auto Glide™ Control Box Harness has 6 sets of electrical connections coming out of the 30 pin Cinch connector.

Figure 3.1.1 **Single Actuator Control Box Harness**

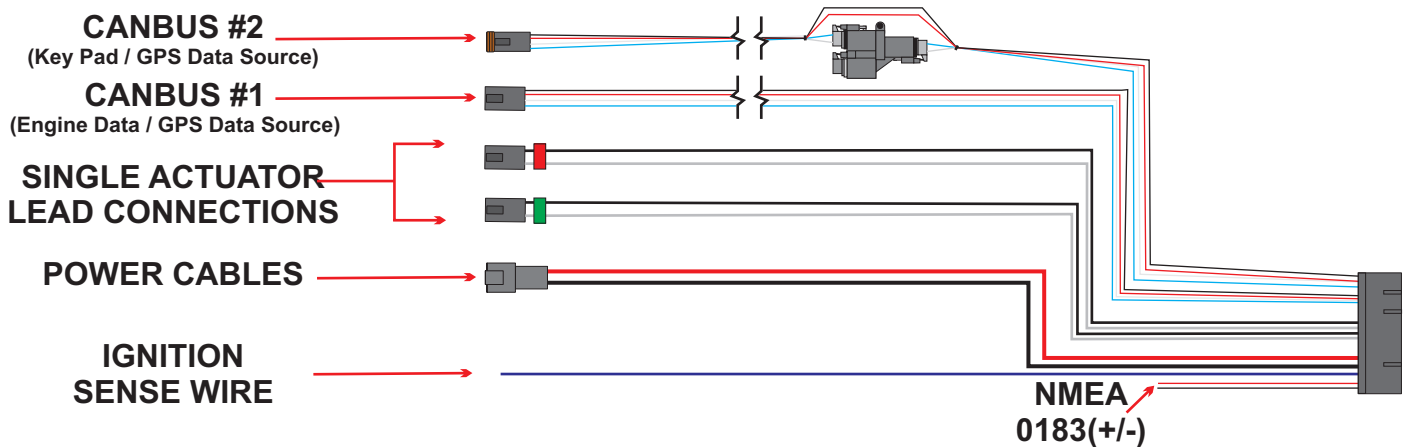
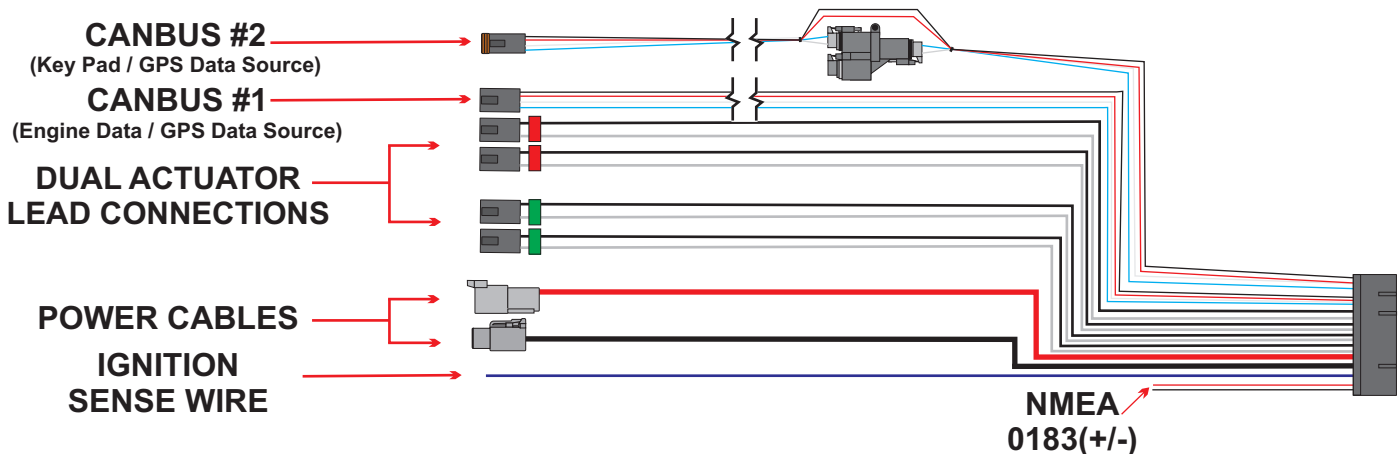

Figure 3.1.2 **Dual Actuator Control Box Harness**





WARNING

The power connections should always be the last connection made.
Power connections should only be made while the battery switch in the OFF position.



CAUTION

Please read through the instructions in their entirety prior to beginning installation! Proper function of this product cannot be assured unless you follow these instructions.

3.2 Auto Glide™ Control Box Harness Installation

- ① **DOWNLOAD YOUR REQUIRED DRAWING FROM THE WEBSITE: WWW.LENCOAUTOGLIDE.COM**
- See sample drawing below
- ② Connect the large black plug on the Auto Glide Control Box Harness into the Auto Glide Control Box.
- Make sure to line up the grooves.
- ③ Screw in the brass hex bolt on the plug into the control box with a 1/4" socket or 1/4" nut driver.
- ④ Connect the actuator lead connections on the control box harness and plug them into the actuator leads or actuator extension harnesses.
- Make sure to connect the wire(s) with the red to the port (left) actuator(s) and the wire(s) with the green to the starboard (right) actuator(s).
- See your Trim Tab Owner's Manual for detailed instructions on Trim Tab installation and actuator hook up.

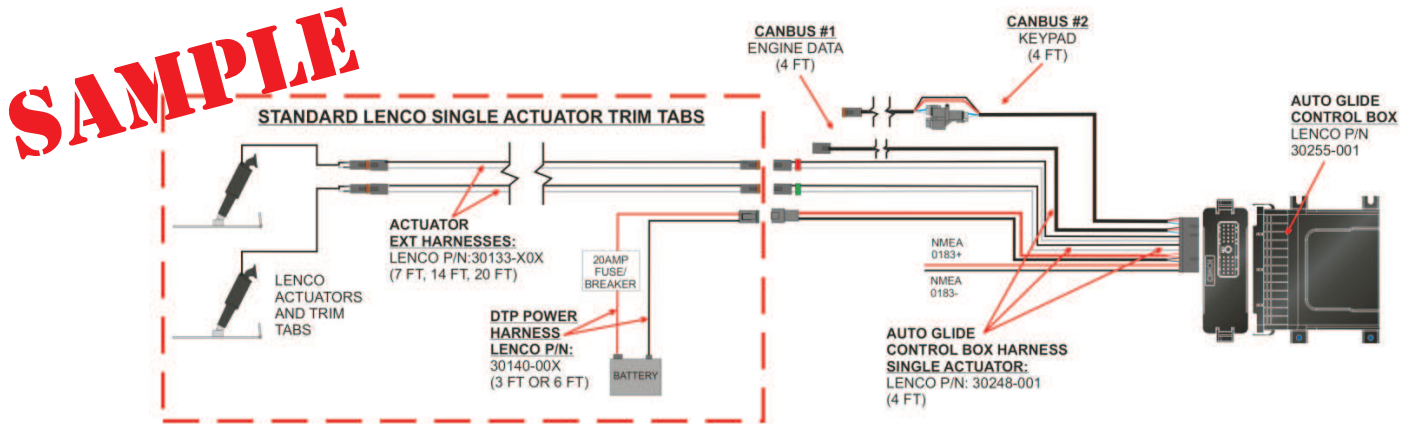

- ⑤ As per your specific drawing (downloaded / printed from website) connect CAN #1 cable to Engine (for engine data) as shown.
- If the Mercury or Yamaha hub is full, you will need to add an additional hub and jumpers.
- ⑥ As per your specific drawing (downloaded / printed from website) connect CAN #2 (Key Pad and GPS Data) as shown.
- ⑦ If your Lenco Trim Tab system is OEM - wired with a power harness, simply connect to the wires as shown in your drawing. If you must run power to the system, you should purchase a power pigtail to plug into the Auto Glide main harness and complete the wiring installation. Lenco also recommends the installation of a battery switch in the system. (See Page 9)
- **NOTE:** Lenco does not recommend the removal of our Deutsch connectors and replacing with hard wiring / butt splicing to connect power to system.

Power Pigtail Choices: (May be purchased at all marine dealers and marine retail outlets)

Single Actuator Systems - Part # 30140-001 36" Power Pigtail or Part # 30140-202 72" Power Pigtail
Dual Actuator Systems - Part # 10249-001 72" Power Pigtail



30140-001 36" Power Pigtail
30140-202 72" Power Pigtail



10249-001 72" Power Pigtail

3.3 Battery Switch Requirements

Lenco Marine recommends that the Auto Glide's main power input be connected to a battery switch to prevent unnecessary drain on your battery while the Auto Glide is in STANDBY MODE. The Auto Glide Control Box and Key Pad draw a very small amount of power (35mA) when it is in STANDBY MODE, but this small current draw will still drain your battery over time. In addition, if the Auto Glide is powering a GPS antenna on CAN 2 (Key Pad Leads), then the amp draw increases and your battery will drain even quicker.

Disconnecting power to the Auto Glide through a battery switch when your boat is not being used will eliminate any current draw from your battery. The following illustrations outline how Lenco Marine recommends you connect the Auto Glide to a battery switch.

STANDARD LENCO SINGLE ACTUATOR TRIM TAB INSTALLATION

NOTE: TURN BATTERY SWITCH "OFF" WHEN BOAT IS NOT BEING USED TO ELIMINATE DRAIN ON BATTERY.

MAIN POWER MUST BE CONNECTED TO BATTERY SWITCH OR PROPERLY RATED ON/OFF SWITCH

SINGLE ACTUATOR SYSTEMS	
BOAT VOLTAGE LEVEL	CIRCUIT PROTECTION RATING
12 VOLT	20 AMP
24 VOLT	10 AMP

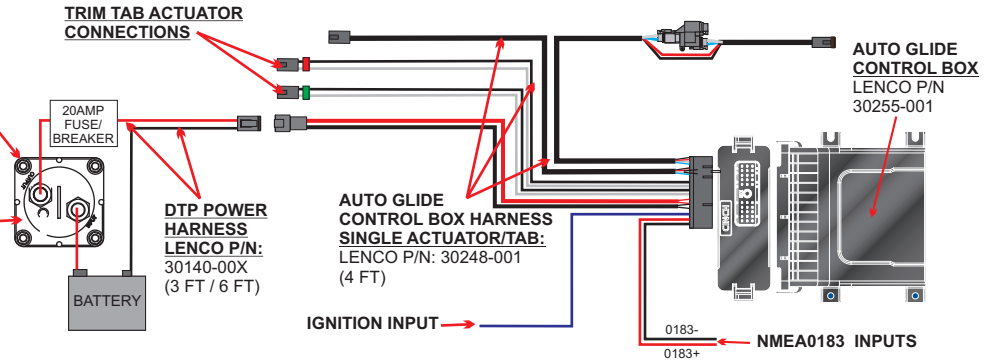

STANDARD LENCO DUAL ACTUATOR TRIM TAB INSTALLATION

NOTE: TURN BATTERY SWITCH "OFF" WHEN BOAT IS NOT BEING USED TO ELIMINATE DRAIN ON BATTERY.

MAIN POWER MUST BE CONNECTED TO BATTERY SWITCH OR PROPERLY RATED ON/OFF SWITCH

DUAL ACTUATOR SYSTEMS	
BOAT VOLTAGE LEVEL	CIRCUIT PROTECTION RATING
12 VOLT	30 AMP
24 VOLT	20 AMP

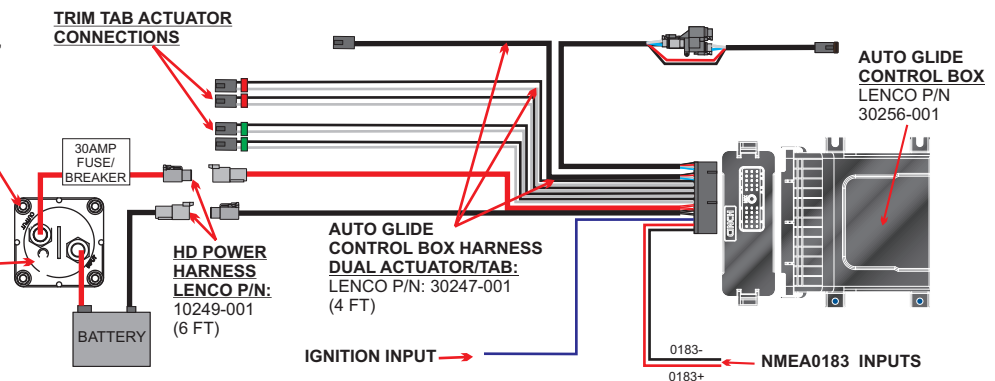

3.4 Optional GPS (Stand Alone) Antenna Installation

The LGC -4000 (NMEA 2000) Antenna/Receiver consists of a male threaded cable connector and the GPS Module. The GPS Module contains a 16-parallel channel GPS+WAAS receiver. The cable length from the connector to the GPS module is 18 inches (45.7 cm).



The GPS module can be installed on any flat surface as long as there is room behind the mounting surface for the screws. See Figures 3.4.1-3.4.2 on page 10 for more information. The optional Lenco Marine 70567-001 GPS Antenna/Receiver Mounting Bracket kit (See Section 3.5 on page 11) allows you to install the antenna on any vertical surface.

3.4 GPS (Stand Alone) Antenna Installation (Continued)

Figure 3.4.1 Surface Mounting the GPS Antenna with No Obstructions Above the GPS Module

The GPS module can be installed on any flat surface that is at least 3-1/2" (90mm) wide. If you are mounting the antenna on an external surface, Lenco Marine recommends that the antenna have a clear, unobstructed view of the sky.

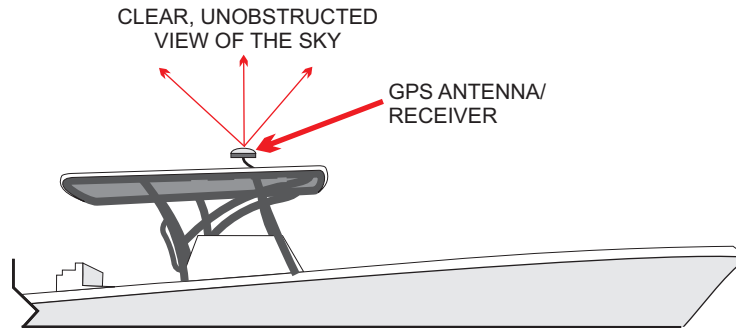
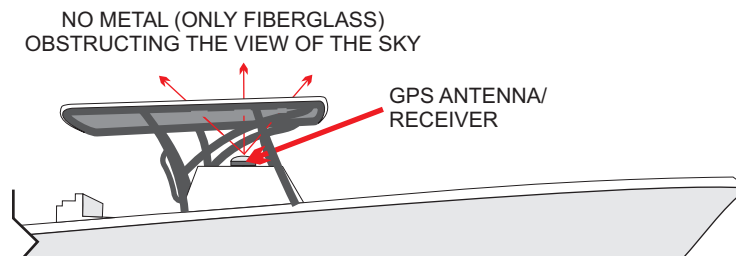

Figure 3.4.2 Mounting the GPS Antenna With ONLY FIBERGLASS Obstructing The View of the Sky

If you cannot mount the GPS antenna to a flat surface with an unobstructed view of the sky, the Lowrance LGC-4000 can be mounted under a fiberglass ceiling. However, you must make sure that there are no metal pipes or plates which obstruct the view of the sky. The Lowrance GPS module can receive GPS Satellite signals through two layers of fiberglass, but will not function properly if metal objects are in between the GPS module and the view of the sky.

Here is an example of mounting the Lowrance LGC-4000 GPS Antenna to a flat surface under a fiberglass hard top. The ceiling directly above the GPS antenna can only be fiberglass. If any of the aluminum bars supporting the fiberglass hard top are directly over the antenna, the GPS module will not be able to receive clear satellite signals.



Here is an example of mounting the Lowrance LGC-4000 GPS Antenna to a flat surface under two (2) layers of fiberglass (Layer 1 = console, Layer 2 = hard top). Both ceilings directly above the GPS antenna can only be fiberglass. If any of the aluminum bars supporting the fiberglass hard top are directly over the antenna, the GPS module will not be able to receive clear satellite signals.

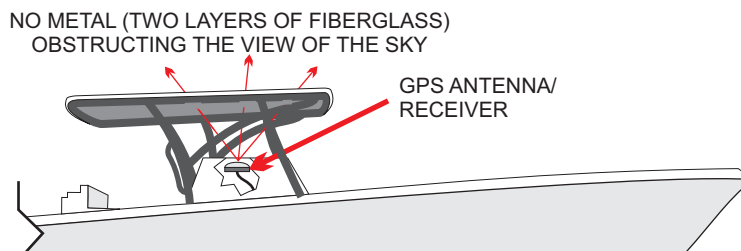

Note: If you install the GPS Antenna/Receiver under a fiberglass ceiling, Lenco Marine recommends that you verify that the Auto Glide is receiving GPS data from the GPS antenna before you physically attach the antenna to the boat. Please review section 4.3 of this manual to learn how to verify that the Auto Glide is receiving GPS data from the GPS antenna.

3.5 Optional Auto Glide™ GPS Mounting Bracket

If you do not have a flat surface to mount the GPS antenna, you can use the Lenco 70567-001 GPS Mounting Bracket Kit to mount the Lowrance LGC-4000 GPS Antenna to a vertical surface. You still need to make sure the antenna module has a clear view of the sky or only has fiberglass above it. Attach the GPS module to the mounting bracket using the two (2) #6-32 stainless steel bolts and nylon nuts that are included in the mounting bracket kit. (See Figure 3.5.1) Then attach the mounting bracket to a vertical surface using the four (4) 1/2" screws that are included in the mounting kit. (See Figure 3.5.2)

Figure 3.5.1

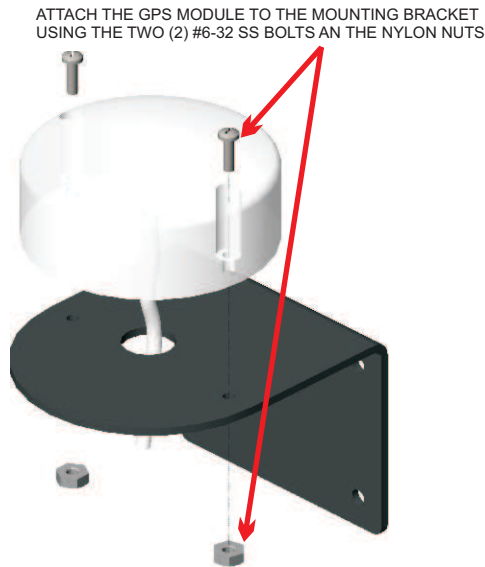
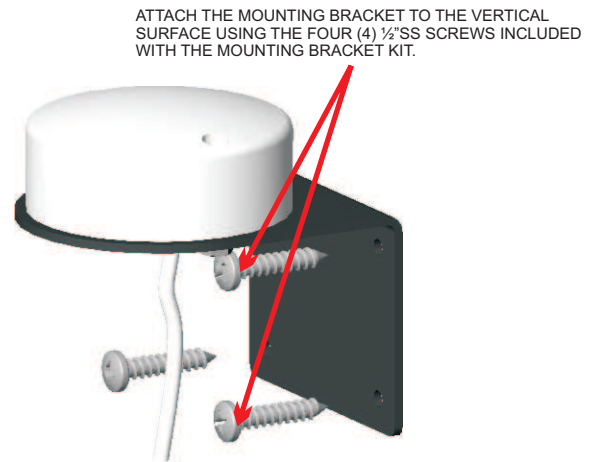

Figure 3.5.2



3.6 Auto Glide™ Second Station Kit Installation

Lenco Marine offers 2nd Station Auto Glide kits ranging in lengths of 10' to 50'. These kits allow you to add a 2nd Key Pad to your Auto Glide system and control the tabs automatically or manually from either station. Each Dual Station Kit includes a 2nd Station Key Pad, CANBUS Splitter Connector Hub and extension harness ranging from 10' to 50'.

Any 2nd Station Auto Glide kit can be used on either a Single or a Dual Actuator Trim Tab System. The following illustration outlines how to connect an Auto Glide 2nd Station Kit:

2ND STATION INSTALLATION EXAMPLE

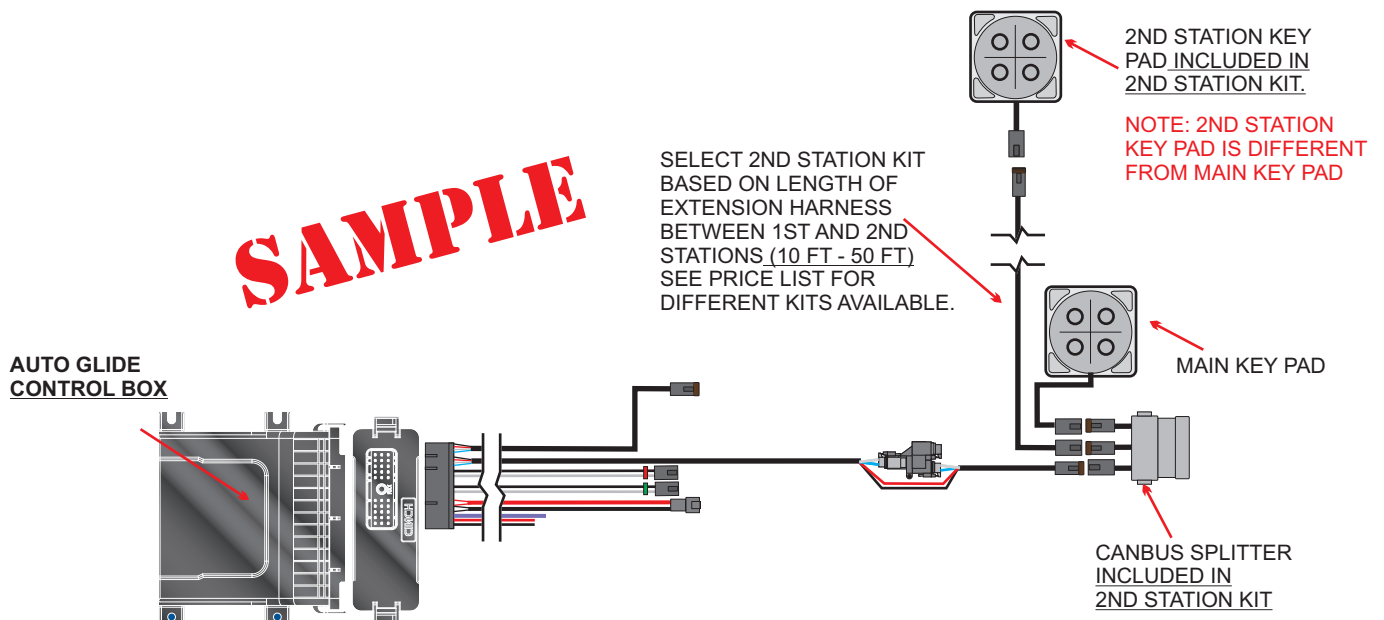

4.1 Auto Glide™ Test Mode

Now that the Auto Glide has been installed and the engine and GPS data sources are connected, Lenco recommends that you verify that the trim tab actuators are operating properly and that the Auto Glide is receiving the CANBUS engine and GPS data it needs to make automatic leveling decisions.

Putting the Auto Glide System into Test Mode

① **Identify Standby Mode:** When battery power is applied to the control box, but the engine is OFF (not running), the Auto Glide defaults to STANDBY MODE. During standby mode, the key pad LEDs are not illuminated. No single button will function if pressed while Auto Glide is in standby mode. (See Figure 4.1.1)

② **Activate Test Mode:** You must activate TEST MODE from STANDBY MODE to verify:

- That the trim tab actuators are operating properly without the engine running.
- The engine CANBUS data and GPS data is being received by the Auto Glide.
- To set/reset Home Roll and Pitch.

To activate TEST MODE, hold all four UP/DN buttons at the same time for **four seconds**. The UP/DN LED indicators will illuminate when all four UP/DN buttons are pressed at the same time. (See Figure 4.1.2)

③ **Verify Test Mode Activation:** Once TEST MODE is activated, the LEDs on the key pad run through a sequence of flashes to notify the operator that the Auto Glide is in TEST MODE. (Figures 4.1.3 and 4.1.4 outline this sequence.)

Figure 4.1.1



Figure 4.1.2

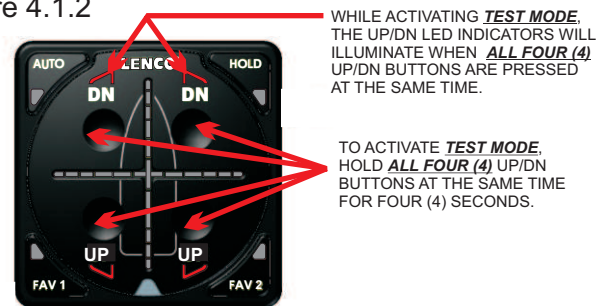

Figure 4.1.3

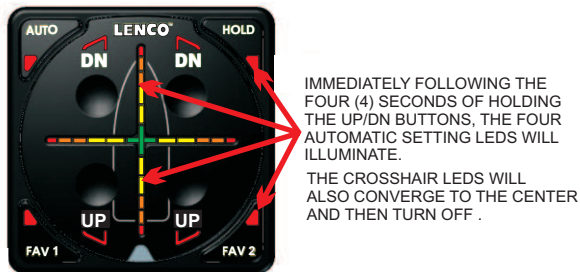
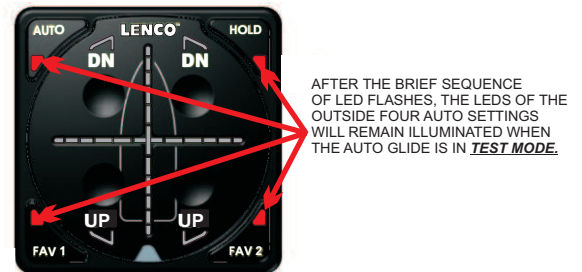

Figure 4.1.4



4.2 Testing The Trim Tab Actuators

From TEST MODE, you can test the functionality of the trim tabs **WITHOUT THE ENGINE RUNNING** by pressing any of the UP/DN buttons on the key pad (See Figure 4.2.1). This is an important step to perform after installing the Auto Glide because it verifies that battery power and the port and starboard trim tabs are connected correctly.

NOTE: Port side UP/DN buttons should operate the Starboard trim tab actuator(s). Starboard side UP/DN buttons should operate the Port trim tab actuator(s).

Figure 4.2.1

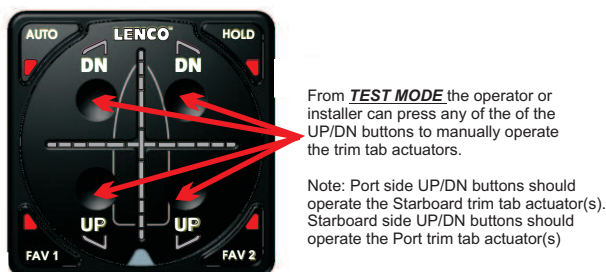

4.3 CANBUS Data Verification

While the Auto Glide is in TEST MODE, you can activate DATA VERIFICATION MODE to confirm that the Auto Glide is receiving the required Engine and GPS data, by pressing FAV 1 or FAV 2 (See Figure 4.3.1). This is a very important step to perform because the Auto Glide cannot make automatic leveling decisions without specific Engine and GPS data.

Figure 4.3.1

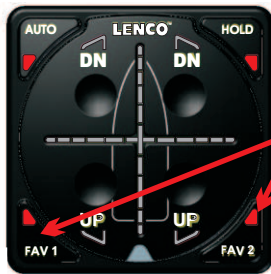

From **TEST MODE** the operator or installer can press either FAV 1 or FAV 2 to initiate **DATA VERIFICATION MODE**.

Verifying Auto Glide is Receiving GPS Data

If your Auto Glide system is receiving GPS Data you should see the following on your key pad:

Upper Quadrant = GPS Heading: Scrolling LEDs between green center crosshair and "12 O'clock". (See Figure 4.3.2)

NOTE: GPS heading may only transmit when the boat is moving.

Right Quadrant = GPS Speed: Scrolling LEDs between green center crosshair and "3 O'clock". (See Figure 4.3.2)

NOTE: GPS speed is always broadcast by GPS. Auto Glide must verify that GPS speed is available before the system can operate properly.

Figure 4.3.2



UPPER QUADRANT = GPS HEADING
SCROLLING LEDS BETWEEN GREEN CENTER CROSSHAIR AND "12 O'CLOCK".

NOTE: GPS HEADING MAY ONLY TRANSMIT WHEN THE BOAT IS MOVED.

RIGHT QUADRANT = GPS SPEED
SCROLLING LEDS BETWEEN GREEN CENTER CROSSHAIR AND "3 O'CLOCK".

NOTE: GPS SPEED IS ALWAYS BROADCAST BY GPS. AUTO GLIDE MUST VERIFY THAT GPS SPEED IS AVAILABLE BEFORE THE SYSTEM CAN OPERATE PROPERLY

Verifying Auto Glide is Receiving Engine Data

If your Auto Glide system is receiving Engine Data you should see the following on your key pad:

Left Quadrant = Engine Gear Position (forward or reverse): Scrolling LEDs between green center crosshair and "9 O'clock". (See Figure 4.3.3)

NOTE: Engine shift / gear position must be either SmartCraft DTS or NMEA 2000 shift data. Fwd or rev shift / gear position may not be broadcast over the CANBUS if the engine is "off".

NOTE: Engine shift / gear position is not required for the Auto Glide to operate normally. Heading, GPS Speed and Engine Speed / RPM are required for the system to operate normally. If engine shift / gear position information is available, the Auto Glide will retract the trim tabs when the engine is in reverse.

Lower Quadrant = Engine Speed / RPM: Scrolling LEDs between green center crosshair and "6 O'clock". (See Figure 4.3.3)

NOTE: Engine speed is always broadcast when the engine ECU is active. Ignition key may have to be in the accessory position for the ECU to become active.

Figure 4.3.3



LEFT QUADRANT = ENGINE GEAR POSITION
(FORWARD OR REVERSE)
SCROLLING LEDS BETWEEN GREEN CENTER CROSSHAIR AND "9 O'CLOCK".

NOTE: ENGINE SHIFT POSITION MUST BE EITHER SMARTCRAFT DTS OR NMEA 2000 SHIFT DATA. FWD OR REV SHIFT POSITION MAY NOT BE BROADCAST OVER THE CANBUS IF THE ENGINE IS IN THE "OFF".

LOWER QUADRANT = ENGINE SPEED (RPM)
SCROLLING LEDS BETWEEN GREEN CENTER CROSSHAIR AND "6 O'CLOCK".

NOTE: ENGINE SPEED IS ALWAYS BROADCAST WHEN ENGINE ECU IS ACTIVE. IGNITION KEY MAY HAVE TO BE IN THE ACCESSORY POSITION FOR THE ECU TO BECOME ACTIVE.

4.3 CANBUS Data Verification (Continued)

Message if Auto Glide is NOT Receiving GPS or Engine Data

If your Auto Glide system is not receiving Engine or GPS Data you should see the following on your key pad:

Only the center crosshair will be illuminated green and the four outside lights will be illuminated red (indicating that you are still in TEST MODE). (See Figure 4.3.4)

If none of the required Engine and GPS data is being received by the Auto Glide, Lenco recommends that you do the following:

- Verify that the engine's ignition switch is placed in the "Accessory " or "Run" position and the engine is transmitting data. The engine instrumentation should be active if the engine is transmitting data.
- Verify that the GPS antenna is not obstructed from receiving satellite signals.
- If the GPS data is received from a NMEA 2000 Network, make sure the GPS is placed in the "ON" position.
- Make sure CAN #1 and CAN #2 data are properly connected to the Auto Glide.

Figure 4.3.4

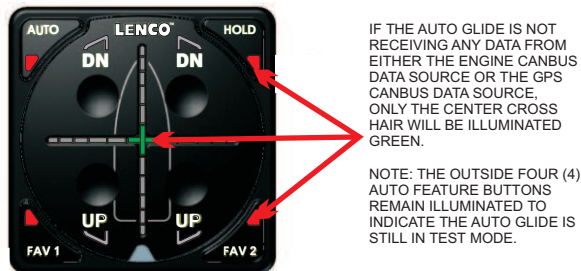

4.4 Exiting Test Mode

Exit Data Verification Mode

Press either FAV 1 or FAV 2 to exit out of DATA VERIFICATION MODE. (See Figure 4.4.1)

NOTE: Once you exit DATA VERIFICATION MODE, the Auto Glide reverts back to TEST MODE.

Exit Test Mode

You should exit TEST MODE and go back into STANDBY MODE before starting the boat's engine. **Press and release** all four UP/DN buttons for 1 second to exit TEST MODE and the Auto Glide automatically reverts back into STANDBY MODE. (See Figure 4.4.2)

Once you exit TEST MODE, the Auto Glide key pad is non-functional in STANDBY MODE. The Auto Glide control box will not activate the key pad until the engine is started and the Auto Glide sees 400 RPM or greater over the CANBUS. Once the Auto Glide sees that the boat's engine(s) are running at 400 RPM or greater, the Auto Glide will check to make sure it is receiving the required GPS data, flash a series of LED indicators on the Key Pad and immediately default to HOME ROLL CALIBRATION MODE.

Figure 4.4.1

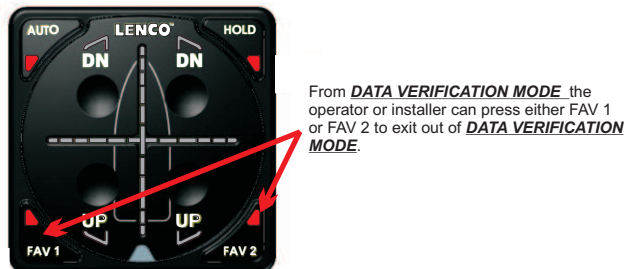

Figure 4.4.2



5.1 Home Roll and Pitch Overview

In order for the Auto Glide to automatically control the Roll and Pitch attitudes of a boat, the boat operator must first set two default HOME POSITIONS:

1. HOME ROLL position (level side to side).

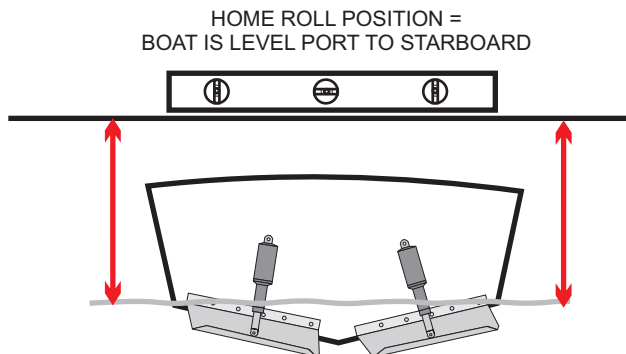

2. HOME PITCH position (most efficient running attitude bow to stern).

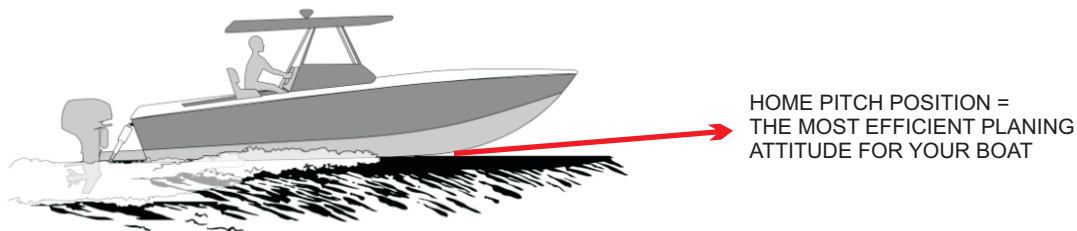

Please follow the setup instructions as carefully as possible to ensure you set the most accurate default HOME positions as possible. However, if you make an error during set up, both HOME ROLL and HOME PITCH positions can be erased and reset. Erasing and Resetting HOME ROLL and HOME PITCH will be described in more detail in section 6.0 in this manual.

NOTE: Setting an accurate HOME ROLL position is very important to the performance of the Auto Glide. Lenco Marine recommends setting the HOME ROLL DEFAULT position in smooth water conditions. If the boat is rocking back and forth when the HOME ROLL DEFAULT position is calibrates, the HOME ROLL position may be slightly skewed to port or starboard.

5.2 Home Roll Setup

- ① **INITIATE SETUP MODE:** Once the Auto Glide installation has been completed and the operator or installer has verified the trim tab actuators are connected properly and the required engine and GPS CANBUS data is being received, it is time to set up HOME ROLL and HOME PITCH.

- A. Verify that power from battery switch is in the “ON” position and the Auto Glide is in STANDBY MODE.
Figure 5.2.1



DURING **STANDBY MODE**,
THE KEY PAD LEDS ARE NOT
ILLUMINATED.

NO **SINGLE** BUTTON WILL
FUNCTION IF PRESSED WHILE
AUTO GLIDE IS IN **STANDBY
MODE**.

- B. Turn your engine(s) “ON” so the Auto Glide sees 400 RPM or greater tach signal from the engine CANBUS.

5.2 Home Roll Setup (Continued)

Once the Auto Glide sees that the boat's engine(s) are running at 400 RPM or greater, the Auto Glide will check to make sure it is receiving the required GPS data, flash a series of LED indicators on the Key Pad and immediately default to **HOME ROLL CALIBRATION MODE**.

NOTE: You can verify that the engine(s) are broadcasting 400 RPM or greater over the engine CANBUS by inspecting the tachometer value on the boat's instrumentation. If the boat's instrumentation shows a tachometer value of 400 RPM or greater, Auto Glide should also be receiving this data and should default to HOME ROLL CALIBRATION MODE.

Here are the sequences of LED flashes that occur as the engine(s) are turned "ON" and the Auto Glide initiates SETUP MODE.

1ST SET OF LED FLASHES

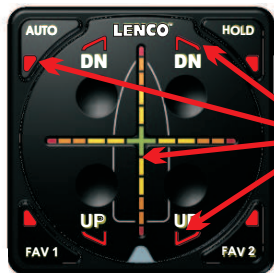

ALL OUTSIDE **AUTO LED INDICATORS** AND **UP/DN INDICATORS** WILL FLASH BRIEFLY.
THE **CROSSHAIR LEDS** WILL BRIEFLY CONVERGE TO THE CENTER.

2ND SET OF LED FLASHES

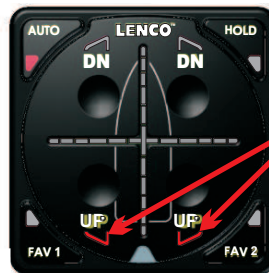

BOTH **UP ACTUATOR LED INDICATORS** FLASH AS THE AUTO GLIDE RETRACTS THE TRIM TABS ACTUATORS TO ENSURE THE TRIM TABS ARE FULLY RETRACTED BEFORE INITIATING **ROLL AND PITCH CALIBRATION MODES**.

3RD SET OF LED FLASHES

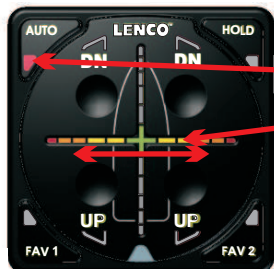

AUTO LED INDICATOR WILL ILLUMINATE TO INDICATE THE AUTO GLIDE IS IN **AUTO MODE**.
HORIZONTAL **CROSSHAIR LEDS** WILL SCROLL FROM SIDE TO SIDE TO INDICATE THE AUTO GLIDE IS IN **HOME ROLL CALIBRATION MODE**.

NOTE: If GPS data is not available at the time the engine(s) are started, the Auto Glide will not default to setup mode. Without the required engine and GPS data, the Auto Glide can not initiate HOME ROLL or PITCH calibration modes.

NOTE: If the Auto Glide does not default to HOME ROLL CALIBRATION MODE when the engine(s) are started and the LEDs on the key pad flash for more than 10 seconds, please refer to the 'System Failure Warning Messages' contained in Owner's Manual B on page 33.

- ② **SET HOME ROLL DEFAULT POSITION:** Once the Auto Glide is in HOME ROLL CALIBRATION MODE, you can set the HOME ROLL DEFAULT POSITION. The Auto Glide will use this HOME ROLL POSITION to level the boat automatically from port to starboard, while on plane.

NOTE: Setting an accurate HOME ROLL position is very important to the performance of the Auto Glide. Lenco Marine recommends setting the HOME ROLL DEFAULT position in **smooth** water conditions. If the boat is rocking back and forth when the HOME ROLL DEFAULT position is calibrated, the HOME ROLL position may be slightly skewed to port or starboard.

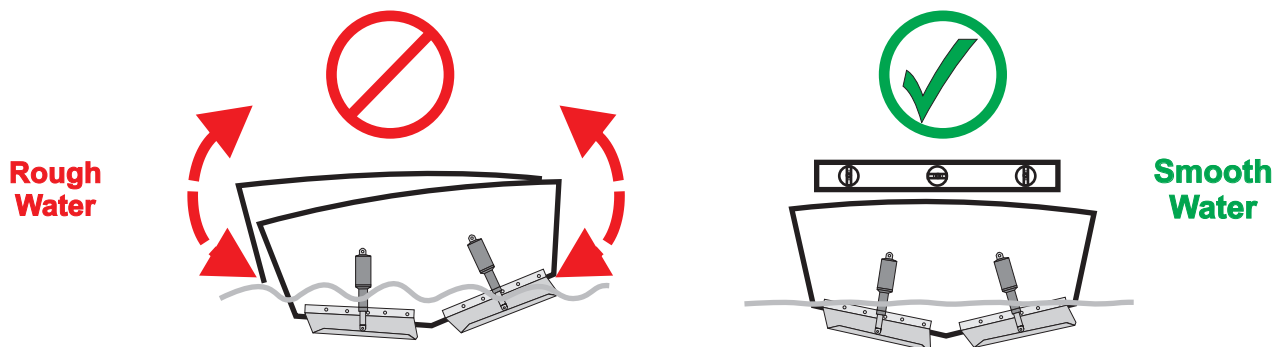

5.2 Home Roll Setup (Continued)

When you determine that the boat is level from side to side, press and release the “AUTO” button one time. The Auto Glide will store the boat’s ROLL POSITION as the DEFAULT HOME ROLL position at the exact moment the Auto button is pushed.



PRESS AND RELEASE THE **AUTO BUTTON** WHILE THE AUTO GLIDE IS IN **HOME ROLL CALIBRATION MODE**.

THE ROLL POSITION OF THE BOAT WILL BE STORED AS THE **DEFAULT HOME ROLL POSITION** AT THE MOMENT THE **AUTO BUTTON** IS PUSHED.

As soon as you release the “AUTO” button on HOME ROLL CALIBRATION MODE, the horizontal crosshair LEDs will stop scrolling and the vertical crosshair LEDs will begin to scroll up and down to indicate that the Auto Glide is in HOME PITCH CALIBRATION MODE.



THE VERTICAL LEDS ON THE CROSSHAIR SCROLL UP AND DOWN TO INDICATE THE AUTO GLIDE IS IN **HOME PITCH CALIBRATION MODE**.

NOTE: DO NOT TOUCH ANY OF THE FOUR (4) UP/DN BUTTONS ON THE KEY PAD WHILE THE AUTO GLIDE IS IN HOME PITCH CALIBRATION MODE. If you touch the UP/DN buttons before setting the HOME PITCH DEFAULT POSITION, the Auto Glide will convert to LIMP HOME MODE (manual Trim Tab control only). Once the Auto Glide is in LIMP HOME MODE, you will have to shut the boat engine(s) off and back on again before the Auto Glide will revert back to HOME PITCH CALIBRATION MODE.

5.3 Home Pitch Setup

SET HOME PITCH DEFAULT POSITION:

NOTE: Water conditions should be calm as possible during HOME PITCH CALIBRATION

- 1 Get the boat on plane **without** using the trim tabs. The tabs will be fully retracted.

WHILE IN **HOME PITCH CALIBRATION MODE**, GET THE BOAT ON PLANE **WITHOUT** USING YOUR TRIM TABS.

NOTE: DO NOT TOUCH ANY OF THE UP/DN BUTTONS ON THE KEY PAD

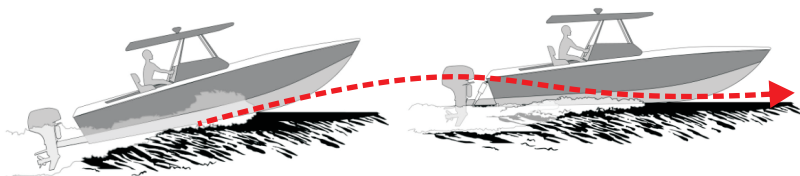

- 2 Once the boat is on plane, ensure the engine(s) are trimmed to match running surface of the boat.

HOLE SHOT - ENGINE TRIM POSITION
TRIM MOTOR(S) UNDER THE BOAT TO ASSIST WITH HOLE SHOT

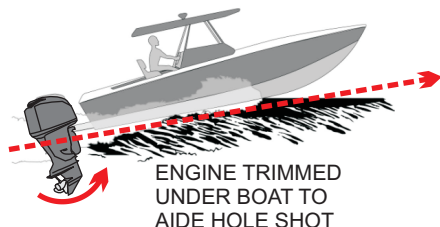

ON PLANE - ENGINE TRIM POSITION
TRIM MOTOR(S) ANGLE SO BOW IS HIGHER THAN NORMAL, BUT NOT PORPOISING (BOW HOPPING)

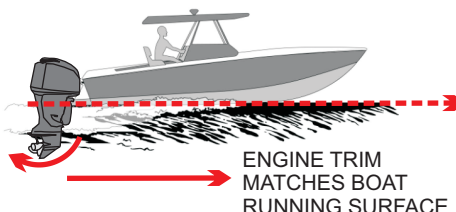

5.3 Home Pitch Setup (Continued)

- ③ Get the boat to a maintained cruising speed.

NOTE: See Figures 5.3.1 and 5.3.2 for recommended cruising speeds.

Figure 5.3.1: GAS ENGINE = 65% OF MAX RPM.

EXAMPLE: GASOLINE 4 STROKE OUTBOARD
MAX RPM = 6000 RPM
CRUISE @ 65% MAX RPM = 3900 RPM

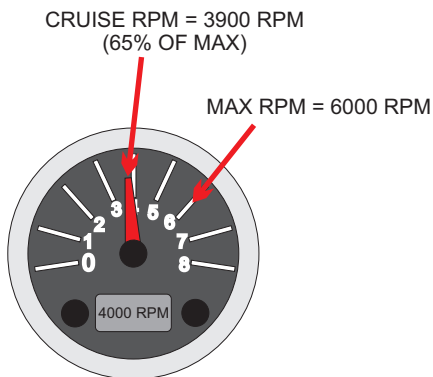
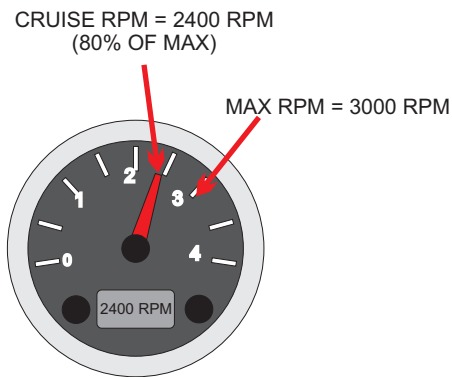
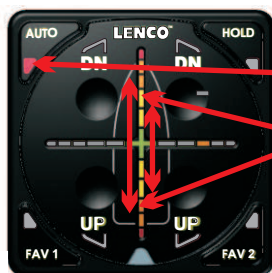

Figure 5.3.2: DIESEL ENGINE = 80% OF MAX RPM.

EXAMPLE: DIESEL INBOARD
MAX RPM = 3000 RPM
CRUISE @ 80% MAX RPM = 2400 RPM



- ④ After getting the boat to cruising speed, press and release the Auto Button to initiate the HOME PITCH CALIBRATION PROCESS.



PRESS AND RELEASE THE **AUTO BUTTON** TO INITIATE **HOME PITCH CALIBRATION MODE**.

THE VERTICAL CROSSHAIR LEDS WILL SCROLL QUICKER AFTER RELEASING THE AUTO BUTTON TO INDICATE THE **HOME PITCH CALIBRATION PROCESS** HAS BEGUN.

Setting the HOME PITCH DEFAULT POSITION takes **66 seconds** from the moment you enter HOME PITCH CALIBRATION PROCESS. You should drive the boat as straight as possible during the **66 seconds** of the HOME PITCH CALIBRATION PROCESS.

NOTE: Adjust people and load on the boat to keep roll as level as possible during the HOME PITCH CALIBRATION PROCESS (Do not use tabs to level load).

HOME PITCH CALIBRATION PROCESS TAKES 66 SECONDS FROM THE MOMENT THE AUTO BUTTON IS PUSHED UNTIL THE HOME PITCH DEFAULT POSITION IS CALCULATED.

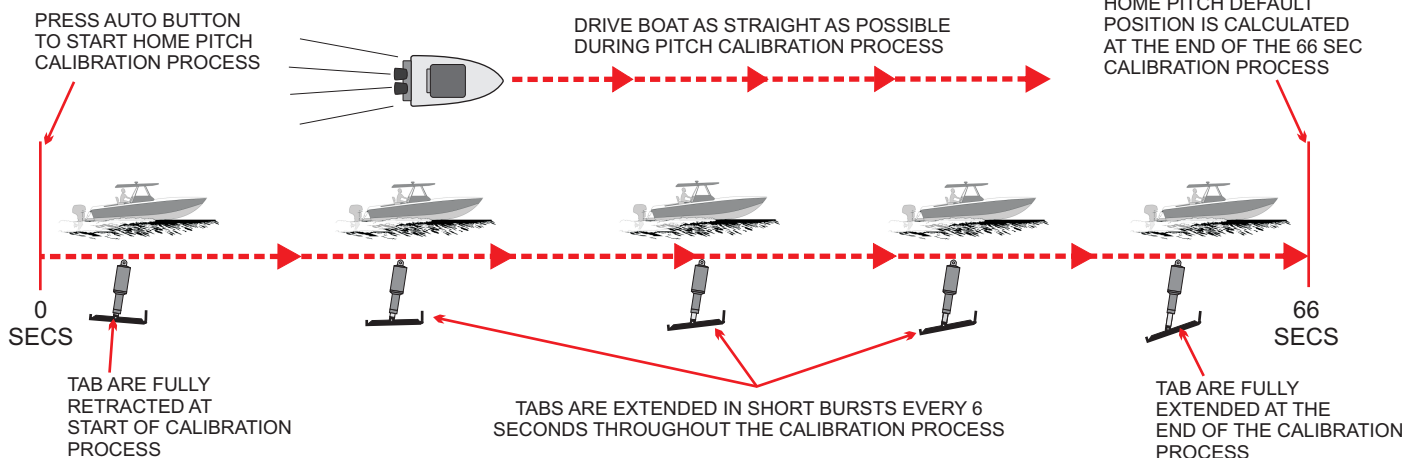

5.3 Home Pitch Setup (Continued)

During the HOME PITCH CALIBRATION PROCESS, the key pad vertical scrolling crosshair LEDs will continue to scroll quickly and the DN LEDs will flash every 6 seconds as the tabs are extended in short bursts.

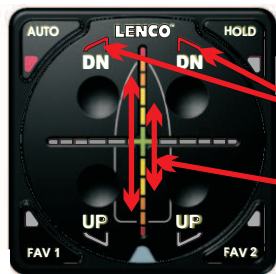

THE DN LED INDICATORS WILL FLASH EACH TIME THE ACTUATORS ARE EXTENDED DURING THE **HOME PITCH CALIBRATION PROCESS**.

THE VERTICAL CROSSHAIR LEDS WILL CONTINUE TO SCROLL QUICKLY THROUGHOUT THE **HOME PITCH CALIBRATION PROCESS**.

- Immediately after the HOME PITCH CALIBRATION PROCESS is complete, the scrolling light disappears, the Auto Glide will calculate the optimum pitch angle for the boat, and will save it as the HOME PITCH DEFAULT POSITION.

The Auto Glide will then immediately default to **AUTO MODE** and begin leveling the boat based on these **HOME ROLL DEFAULT POSITION** and the **HOME PITCH DEFAULT POSITION**.

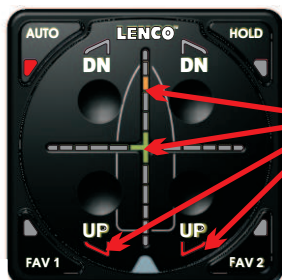

AS SOON AS THE **HOME PITCH DEFAULT POSITION** IS SAVED, THE VERTICAL LEDS ON THE CROSSHAIR STOP SCROLLING

THE AUTO GLIDE WILL DEFAULT TO **AUTO MODE** AND BEGIN TO RETRACT THE TRIM TABS IN SHORT BURSTS BASED ON THE ROLL AND PITCH POSITION OF THE BOAT.

THE TABS WILL CONTINUE TO COME UP UNTIL THE BOAT REACHES THE HOME PITCH DEFAULT POSITION.

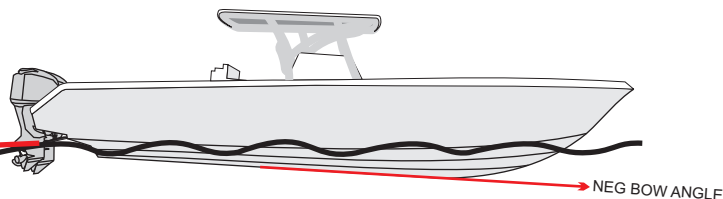
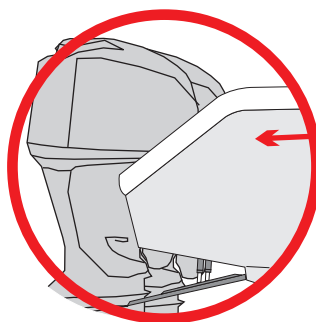

TRIM TABS ARE FULLY DEPLOYED IMMEDIATELY AFTER COMPLETION OF **HOME PITCH CALIBRATION PROCESS**.

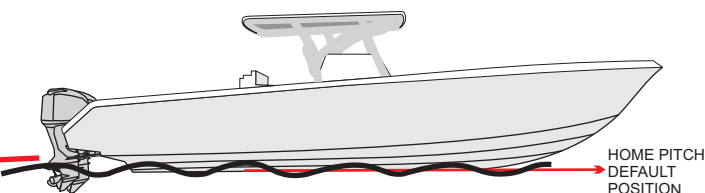
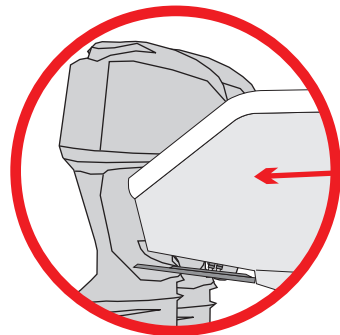

TRIM TABS RETRACT IN BRIEF BURSTS UNTIL BOAT'S RUNNING ANGLE REACHES **HOME PITCH DEFAULT POSITION**.

The setup process is now complete

6.1 Resetting Home Pitch Default Position ONLY

If you experience a problem during the HOME PITCH CALIBRATION PROCESS and feel the resulting HOME PITCH DEFAULT POSITION is not accurate, you can erase the HOME PITCH DEFAULT POSITION from TEST MODE. You must first erase the HOME PITCH DEFAULT POSITION before you can re-enter the HOME PITCH CALIBRATION PROCESS and allow the AUTO GLIDE to learn a new HOME PITCH DEFAULT POSITION.

NOTE: HOME ROLL DEFAULT POSITION will not be affected when you erase the HOME PITCH DEFAULT POSITION. Section 6.2 will explain how to erase the HOME ROLL DEFAULT POSITION.

The following illustrations outline how to erase the HOME PITCH DEFAULT POSITION from TEST MODE.

① ACTIVATE TEST MODE:

With your motor(s) turned “OFF”, activate TEST MODE from STANDBY MODE by pressing and holding all four (4) UP/DN buttons on the Key Pad for four (4) seconds.

WHILE ACTIVATING **TEST MODE**, THE UP/DN LED INDICATORS WILL ILLUMINATE WHEN **ALL FOUR (4)** UP/DN BUTTONS ARE PRESSED AT THE SAME TIME.

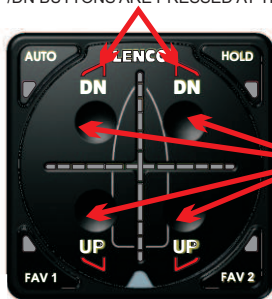

TO ACTIVATE **TEST MODE**, HOLD **ALL FOUR (4)** UP/DN BUTTONS AT THE SAME TIME FOR FOUR (4) SECONDS.

② VERIFY TEST MODE ACTIVATION:

Once TEST MODE is activated, the LEDs on the key pad run through a sequence of flashes to notify the operator that the Auto Glide is in TEST MODE. The following illustrations outline this sequence of LED flashes signifying the Auto Glide is in TEST MODE:



IMMEDIATELY FOLLOWING THE FOUR (4) SECONDS OF HOLDING THE UP/DN BUTTONS, THE FOUR AUTOMATIC SETTINGS LEDS WILL ILLUMINATE. THE CROSSHAIR LED INDICATORS WILL ALSO CONVERGE TO THE CENTER AND THEN GO BLANK.

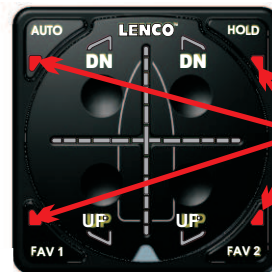

AFTER THE BRIEF SEQUENCE OF LED FLASHES, THE OUTSIDE FOUR AUTOMATIC SETTINGS LED INDICATORS WILL REMAIN ILLUMINATED WHEN THE AUTO GLIDE IS IN **TEST MODE**.

③ ERASING HOME PITCH DEFAULT POSITION:

Once the Auto Glide is in TEST MODE, press and hold the “HOLD” AUTOMATIC SETTING button until the “HOLD” LED INDICATOR flashes three times. The three flashes of the “HOLD” LED INDICATOR confirms that the HOME PITCH DEFAULT POSITION has been erased.



WHILE THE AUTO GLIDE IS IN **TEST MODE**, PRESS AND HOLD THE “HOLD” AUTOMATIC SETTING BUTTON UNTIL THE “HOLD” LED INDICATOR FLASHES THREE (3) TIMES.

ONCE THE “HOLD” LED INDICATOR STOPS FLASHING, THE **HOME PITCH DEFAULT POSITION** HAS BEEN ERASED.

6.1 Resetting Home Pitch Default Position ONLY (Continued)

④ EXIT TEST MODE:

After erasing the HOME PITCH DEFAULT POSITION, you must exit TEST MODE before you can re-enter the HOME PITCH CALIBRATION MODE. Exit TEST MODE by holding down all four (4) UP/DN buttons for one (1) second. The AUTOMATIC SETTING LED INDICATORS will go blank indicating the Auto Glide is back in STANDBY MODE.

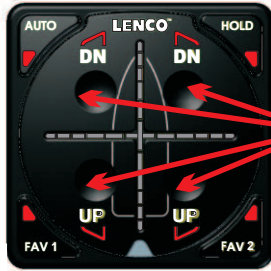

TO EXIT **TEST MODE**, HOLD ALL FOUR (4) UP/DN BUTTONS AT THE SAME TIME FOR ONE (1) SECOND.

⑤ RESET HOME PITCH DEFAULT POSITION:

Restart your motor(s) and the Auto Glide will default to HOME PITCH CALIBRATION MODE. The VERTICAL CROSSHAIR LED INDICATORS will scroll up and down to indicate the Auto Glide is ready to reset a new HOME PITCH DEFAULT POSITION.

Return to page 17 of this manual for HOME PITCH SETUP INSTRUCTIONS and follow the instructions to set the new HOME PITCH DEFAULT POSITION.

6.2 Resetting Home Roll and Home Pitch Default Positions

If you need to reset the HOME ROLL DEFAULT POSITION, you will also need to erase and reset the HOME PITCH DEFAULT POSITION. The Auto Glide erases both HOME ROLL AND HOME PITCH DEFAULT POSITIONS when you erase the HOME ROLL DEFAULT POSITION. Even if you only want to erase the HOME ROLL DEFAULT POSITION, the Auto Glide will automatically erase the HOME PITCH DEFAULT POSITION.

The following instructions explain how to erase and reset both HOME ROLL AND HOME PITCH DEFAULT POSITIONS.

① ACTIVATE and VERIFY TEST MODE:

SEE STEPS 1 & 2 ON PAGE 20

② ERASING HOME ROLL AND PITCH DEFAULT POSITION:

Once the Auto Glide is in TEST MODE, press and hold the "AUTO" AUTOMATIC SETTING button until the "AUTO" LED INDICATOR flashes three times. The three flashes of the "AUTO" LED INDICATOR confirm that both the HOME ROLL AND PITCH DEFAULT POSITIONS have been erased.

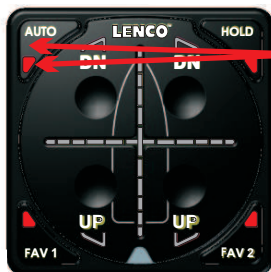

WHILE THE AUTO GLIDE IS IN **TEST MODE**, PRESS AND HOLD THE "AUTO" AUTOMATIC SETTING BUTTON UNTIL THE "AUTO" LED INDICATOR FLASHES THREE (3) TIMES.

ONCE THE "AUTO" LED INDICATOR STOPS FLASHING, BOTH THE **HOME ROLL AND PITCH DEFAULT POSITIONS** HAVE BEEN ERASED.

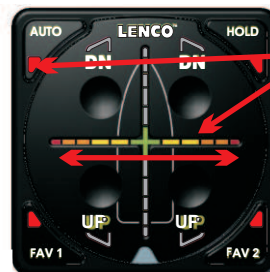

AS SOON AS THE "AUTO" LED INDICATOR STOPS FLASHING, THE **HORIZONTAL CROSS HAIR LED INDICATORS** SCROLL BACK AND FORTH TO INDICATE THE AUTO GLIDE HAS RE-ENTERED **HOME ROLL CALIBRATION MODE**.

ONCE THE AUTO GLIDE HAS ERASED THE **HOME ROLL DEFAULT POSITION**, YOU **MUST RESET THE HOME ROLL DEFAULT POSITION** BEFORE EXITING OUT OF **TEST MODE**.

NOTE: IF YOU DO NOT RESET THE HOME ROLL DEFAULT POSITION BEFORE EXITING TEST MODE, THE AUTO GLIDE WILL AUTOMATICALLY RESAVE THE PREVIOUS HOME ROLL DEFAULT POSITION WHEN YOU EXIT OUT OF TEST MODE.

6.2 Resetting Home Roll and Home Pitch Default Positions (Continued)

③ RESET HOME ROLL DEFAULT POSITION:

Once the Auto Glide is in ROLL CALIBRATION MODE, you will need to reset the HOME ROLL DEFAULT POSITION by pressing and releasing the “AUTO” Automatic button.



PRESS AND RELEASE THE “**AUTO**” **AUTOMATIC SETTING** BUTTON WHILE THE AUTO GLIDE IS IN **HOME ROLL CALIBRATION MODE**. THE NEW ROLL POSITION OF THE BOAT WILL BE STORED AS THE **HOME ROLL DEFAULT POSITION** AT THE MOMENT THE **AUTO** **BUTTON** IS PUSHED.

NOTE: SETTING AN ACCURATE HOME ROLL DEFAULT POSITION IS VERY IMPORTANT TO THE PERFORMANCE OF THE AUTO GLIDE. LENCO MARINE RECOMMENDS SETTING THE HOME ROLL DEFAULT POSITION IN SMOOTH WATER CONDITIONS. IF THE BOAT IS ROCKING BACK AND FORTH WHEN THE HOME ROLL DEFAULT POSITION IS CALIBRATED, THE HOME ROLL POSITION MAY BE SLIGHT SKEWED TO PORT OR STARBOARD.

④ CONFIRMATION NEW HOME ROLL DEFAULT POSITION HAS BEEN SAVED:

Once you release the “AUTO” AUTOMATIC SETTING button the “AUTO” LED INDICATOR will flash three times. The three flashes of the “AUTO” LED INDICATOR confirm that the new HOME ROLL DEFAULT POSITIONS has been stored. The HORIZONTAL CROSSHAIR LED INDICATORS will also stop scrolling to indicate the Auto Glide has exited out of HOME ROLL CALIBRATION MODE and has defaulted back into TEST MODE.

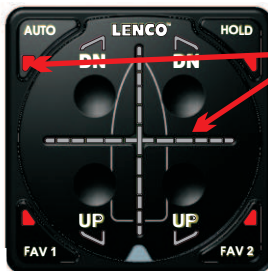

AS SOON AS THE “**AUTO**” **LED INDICATOR** STOPS FLASHING, THE **HORIZONTAL CROSSHAIR LED INDICATORS** ALSO STOP SCROLLING TO INDICATE THE AUTO GLIDE HAS SAVED THE **HOME ROLL DEFAULT POSITION**.

ONCE THE AUTO GLIDE HAS STORED THE **HOME ROLL DEFAULT POSITION**, IT DEFAULTS BACK TO **TEST MODE**.

⑤ EXIT TEST MODE:

After erasing the HOME PITCH DEFAULT POSITION, you must exit TEST MODE before you can re-enter the HOME PITCH CALIBRATION MODE. Exit TEST MODE by holding down all four (4) UP/DN buttons for one (1) second. The AUTOMATIC SETTING LED INDICATORS will go blank indicating the Auto Glide is back in STANDBY MODE. SEE ILLUSTRATION ON PAGE 21.

⑥ RESET HOME PITCH DEFAULT POSITION:

Restart your motor(s) and the Auto Glide will default to HOME PITCH CALIBRATION MODE. The **VERTICAL CROSSHAIR LED INDICATORS** will scroll up and down to indicate the Auto Glide is ready to reset a new HOME PITCH DEFAULT POSITION.

Return to page 15 of the HOME ROLL AND PITCH SETUP INSTRUCTIONS and follow the instructions to set the new HOME PITCH DEFAULT POSITION.

END OF OWNER’S MANUAL A
Refer to Owner’s Manual B for Operational Instructions