

Selector Battery Switch with Alternator Field Disconnect

771-SFD 400A Selector Field Disconnect (Retail Packed)
 771-SFD-B (Bulk Packed)

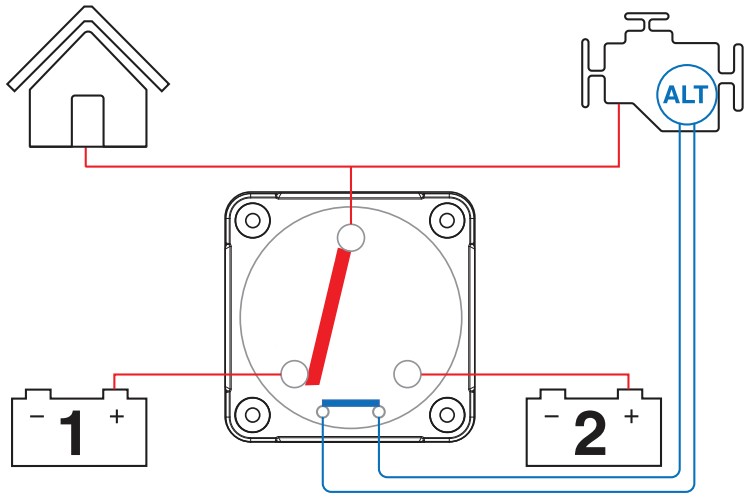

CE 5 YEAR WARRANTY

This innovative switch combines the benefits of a selector switch, with a second set of contacts to protect electronics and the alternator if the battery switch is inadvertently turned off while the engine is running.

Features & Benefits:

- Protects Alternator while switching
- Industry standard footprint
- Three mounting options – surface, rear-panel and front-panel
- Compatible with metric and imperial mounting fasteners
- User friendly design
- Removable knob for isolation/safety
- Includes back cover and three side panels for security and cable protection
- Designed to withstand harsh marine environments
- High temperature reinforced plastics

Specifications:

- Continuous rating: 400A
- Intermittent rating: 600A
- Cranking rating: 1500A
- AFD Field Contacts: 10A Continuous Rating
- Connection stud size: M10 (3/8")
- AFD stud size M4 (5/32")
- 12-48V DC (Higher voltage applications on request)
- IP66 – protection from powerful water jets
- Ignition protected
- Independently tested to meet UL1107 standards
- CE

Installation Instructions: IMPORTANT! Read before installing

- It is recommended that electrical terminations and connections are carried out by a marine electrical technician.
- These battery switches are for isolation purposes and are not designed for switching under load. Ensure there are no circuits with high inductive loads directly connected to the switch in order to prevent any sudden in-rush of current which may cause damage to the switch.
- Although specially selected chemical resistant materials have been used, we recommend that for maximum product life only plastic safe corrosion inhibiting sprays are used.
- Ensure all cables are sized correctly for the loads they carry. Please refer to www.bepmarine.com to calculate correct cable sizes.
- Ensure all electrical connections are correctly tightened to prevent any damage to the battery switch.
- **WARNING:** Ensure field disconnect contacts are wired to interrupt alternator field current.

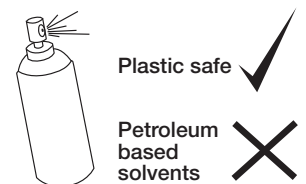

Surface Mount Instructions

1. Choose mounting location on a flat surface close to the batteries
2. Select panhead (or similar) screws for mounting - use either M5 or 10g imperial (not included)
3. Knock or drill out plastic skin from screw holes in backplate
4. Select panhead (or similar) machine screws and nuts to secure switch to backplate - use either M6 x 40mm or 0.25" x 1.5" (not included). Alternatively longer screws should be used if bolting all the way through the bulkhead/surface
5. Place nuts for machine screws into nut recesses, then screw backplate into position
6. Connect cables to studs ensuring that batteries and loads are correctly fitted
7. Check that spring washers are fitted beneath nuts
8. Tighten the stud nuts to 13.5 Nm (10 lbf)
9. Tighten the AFD stud nuts to 2 Nm (1.5 lbf)
10. Slot the side panel(s) into the backplate as required
11. Clip battery switch and cable assembly into backplate
12. Secure switch in place with machine screws, engaging into nuts under backplate
13. Ensure cables are secured to ISO/ABYC standards, and that cables are supported so they are not placing unnecessary strain on the battery switch studs (see diagram)
14. With switch in "OFF" position connect battery positive leads at battery
15. Check switch operation (as per below)

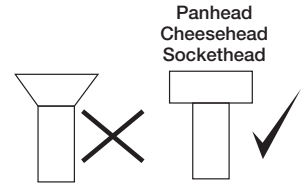
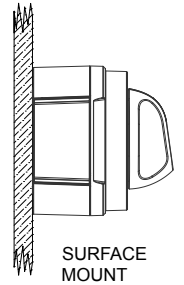

Panel Mount Instructions

1. Choose mounting location
2. Ensure positive leads are removed from battery banks
3. Use the mounting template (shown on rear page) to mark hole positions
4. Drill four machine screw holes and the 92mm (or 3 5/8") hole for the switch body.
5. Front panel mounting only: either recess for the four clipping features (see template) or cut/file off these features from the battery switch plate
6. Mount switch to panel using M6 (or 1/4") machine screws - note: use either pan or cheesehead screws only
7. Connect cables to studs ensuring that batteries and loads are correctly fitted
8. Check that spring washers are fitted beneath nuts
9. Tighten the stud nuts to 13.5 Nm (10 lbf)
10. Tighten the AFD stud nuts to 2 Nm (1.5 lbf)
11. Rear panel mounting only: back plate and side panels can also be clipped to the switch for cable protection/insulation
12. Ensure cables are secured to ISO/ABYC standards, and that cables are supported so they are not placing strain on the battery switch studs (see diagram)
13. With switch in "OFF" position connect battery positive leads at battery
14. Check switch operation (as below)

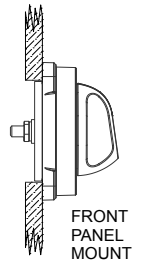
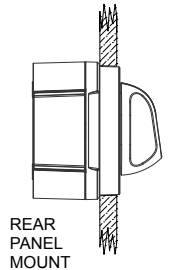

Check switch operation:

- a. Loads have no voltage in "OFF" position and AFD contacts are open
- b. Loads have voltage in "1 ON" position and the AFD contacts are closed
- c. Load share voltage in "2 ON" position and AFD contacts are closed
- d. Loads have voltage in 1&2 positions and AFD contact are closed

Dimensions:

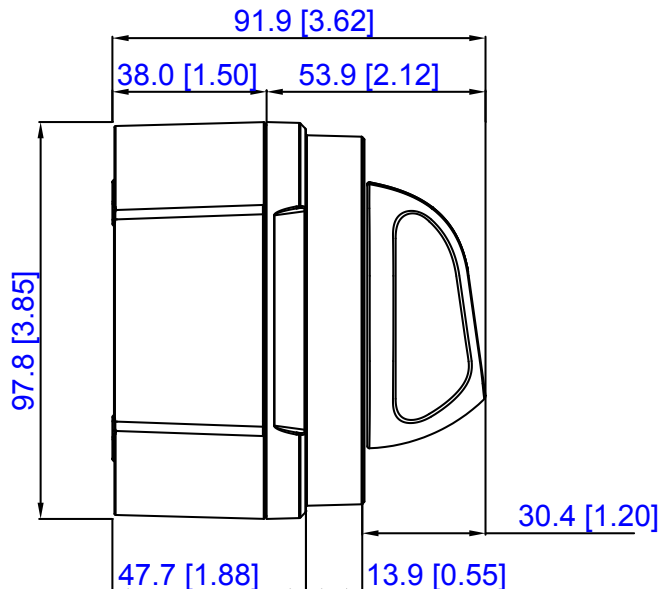

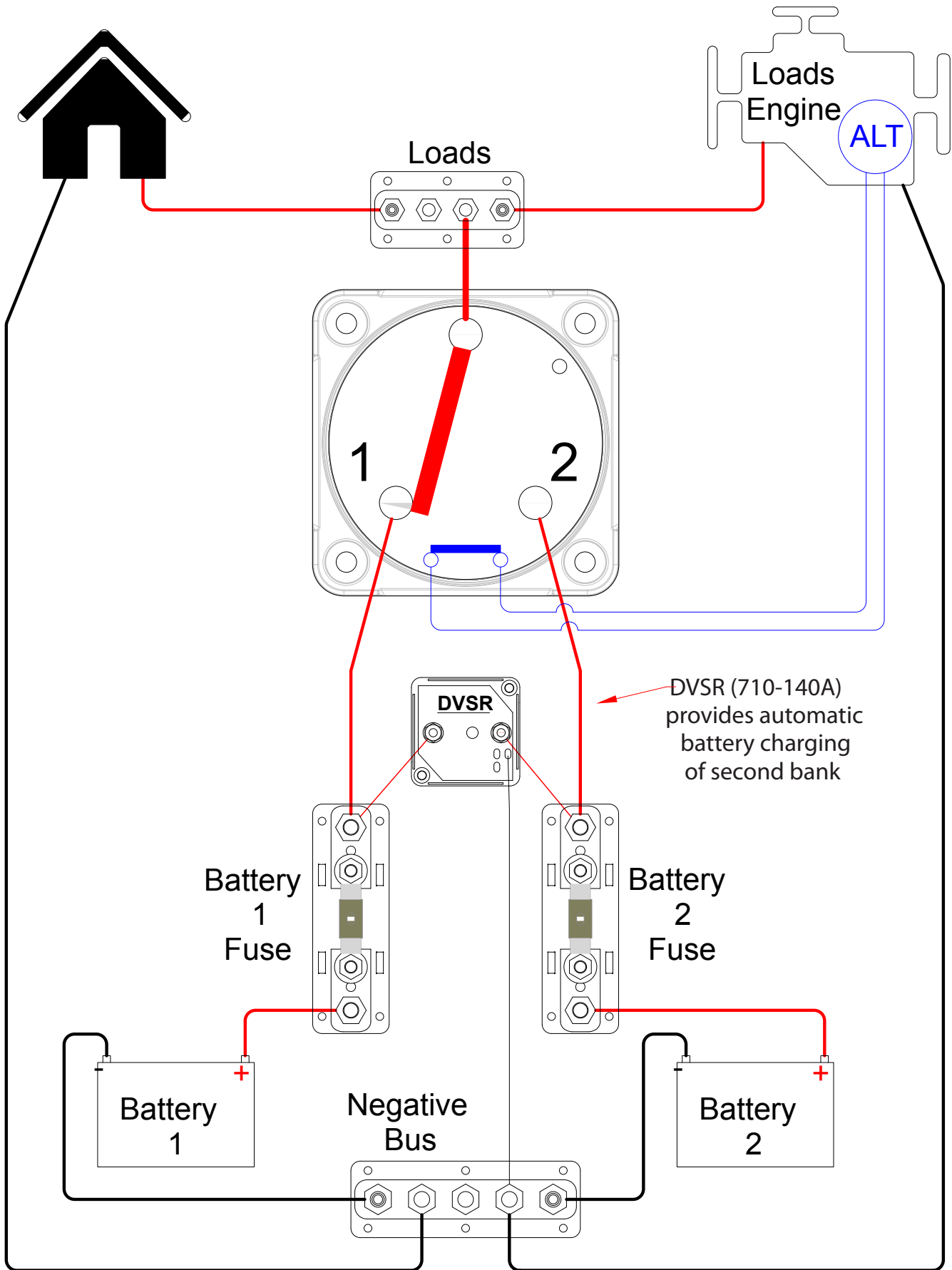

Example System:

NOTE -This diagram is a guide only showing Selector With Field Disconnect connections and is not intended as a full electrical systems wiring diagram.

Please check scale before using

Mounting Template

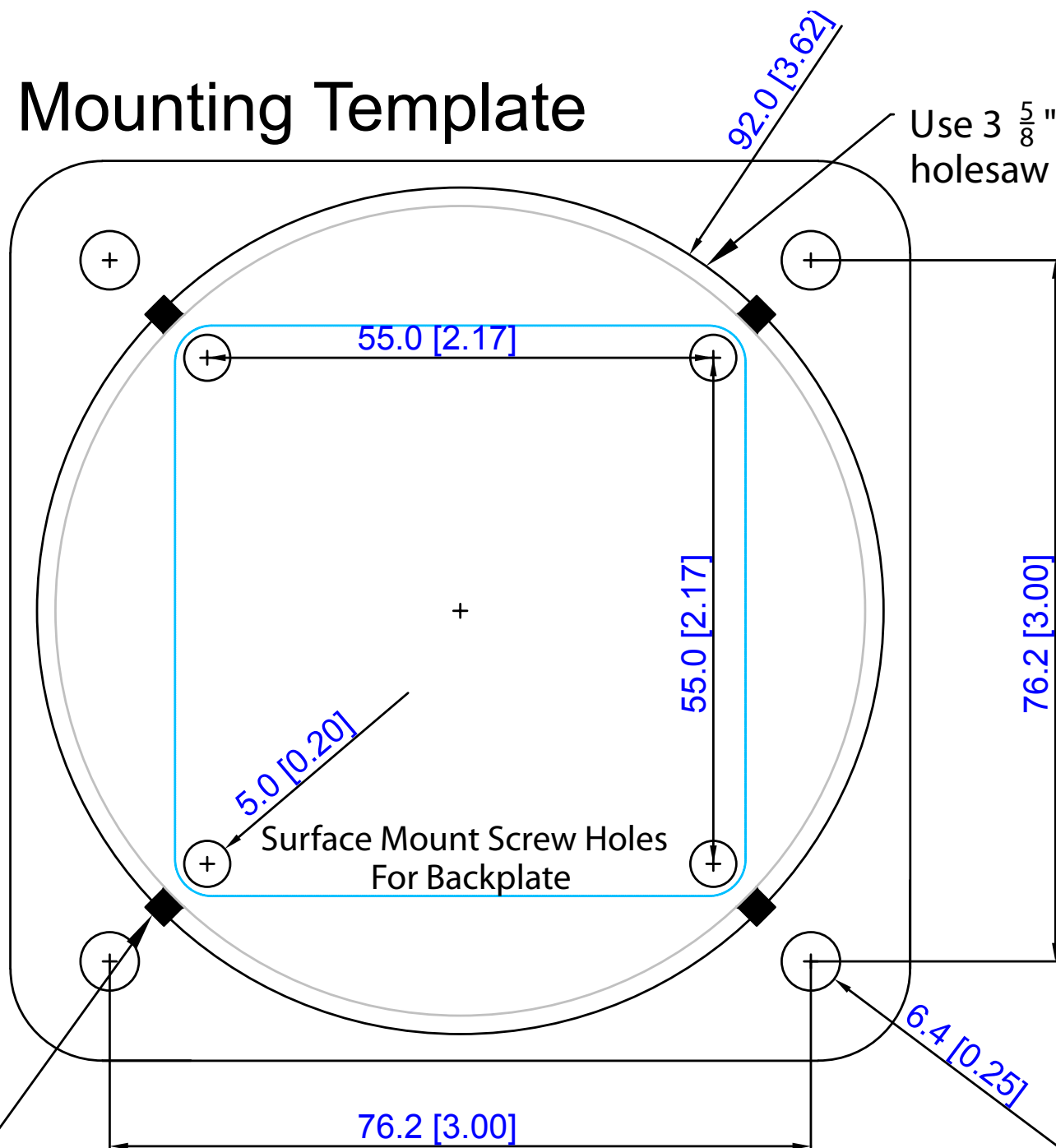

Clipping feature:

- Either remove clipping features or recess panel when front panel mounting