

BILL of MATERIALS

NO.	REVISION	DATE
1	ADDED (8) 10-24 INSERTS-ATS	2/19/14

Qty.	DESCRIPTION
1	ESU UNIVERSAL SENDER W/ RETURN
1	ALUM. PL3 PICKUP W/O BARB
1	3/8 NPT INSERT W/ 5/8" BARB (VENT)
1	Ø1.50 X 2.75 MOLDED FILL
	OVERALL HEIGHT 18.75"

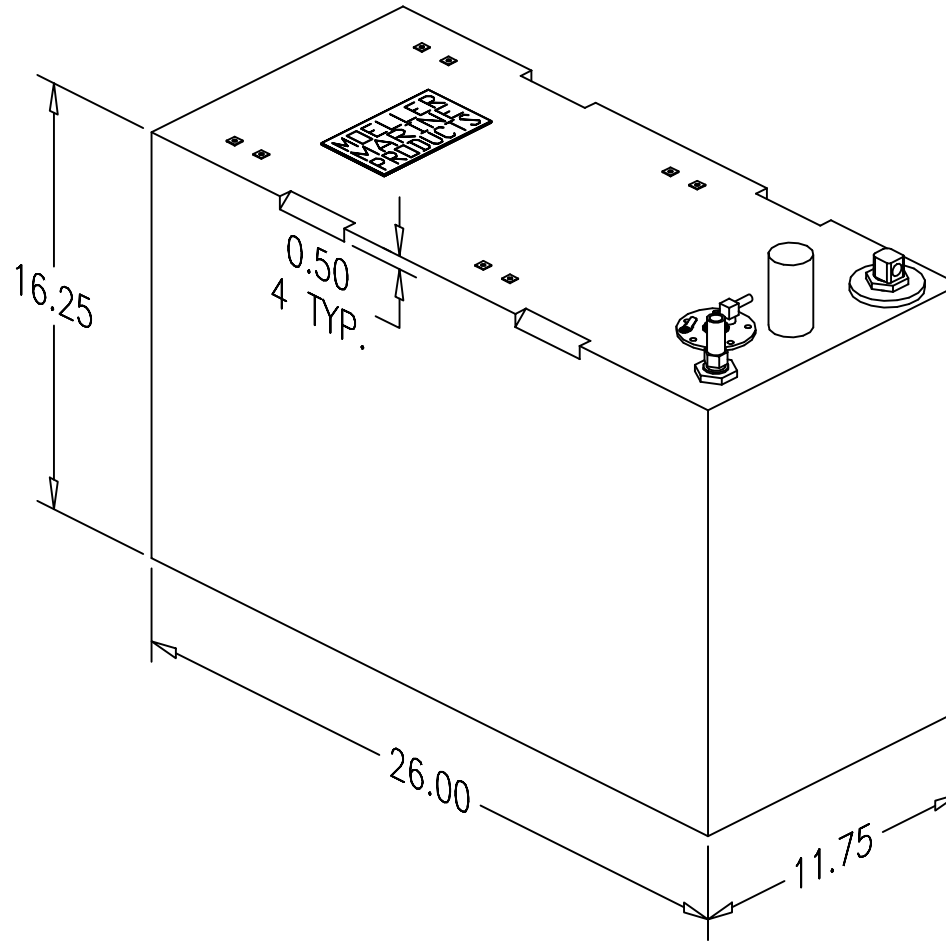

APPROVED

NOTE: ALL EDGES R0.38
UNLESS OTHERWISE NOTED

PAGE 1 OF 2

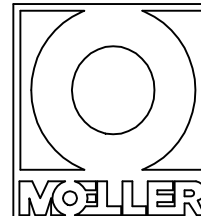

DESCRIPTION	20 GALLON FUEL TANK		
PART #	FT2099-3	COLOR	NATURAL
MATERIAL	CROSSLINK POLYETHYLENE		
TOLERANCES	±1.5% UNLESS OTHERWISE NOTED		
WALL THK.	0.200"	DATE	5/7/10
DRAWN BY	MOELLER ENGINEERING		

THIS DRAWING AND THE ATTACHED DRAWINGS (AND THE DATA SHOWN THERON) IS CONFIDENTIAL AND PROPRIETARY AND SHALL NOT BE USED, DISCLOSED TO OTHERS, REPRODUCED FOR ANY PURPOSE EXCEPT FOR QUOTATION TO OR ORDER BY MOELLER MARINE PRODUCTS, INC. AND/OR IT'S SUBSIDIARIES WITHOUT THEIR WRITTEN CONSENT TO THE USE OF SUCH DRAWINGS AND/OR DATA.

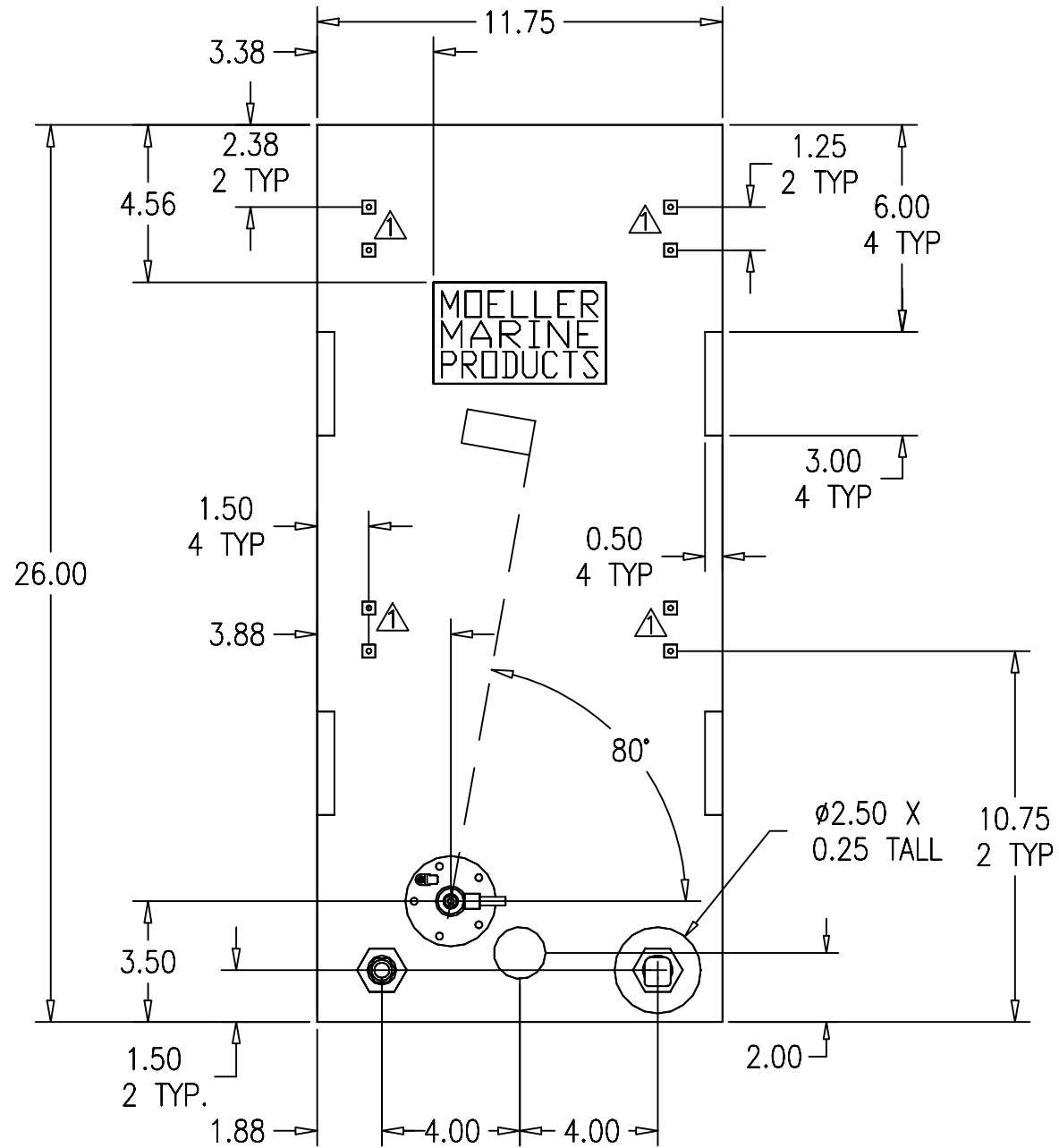

NOTE: STRAP LOCATIONS ARE BEVELED 45°.