

This document is submitted in confidence contains proprietary information which should not be reproduced or transferred in whole or in parts to other documents or disclosed to others or used for manufacturing or any other purpose without prior written permission of Newmar Power, LLC.

REVISIONS			
Rev.	Description	Originator	Date
Ori.(F)	3D Dwgs as per Jason M.H. Requirements on 041323	Johnson	043023



Fig. A) RIGHT REAR VIEW

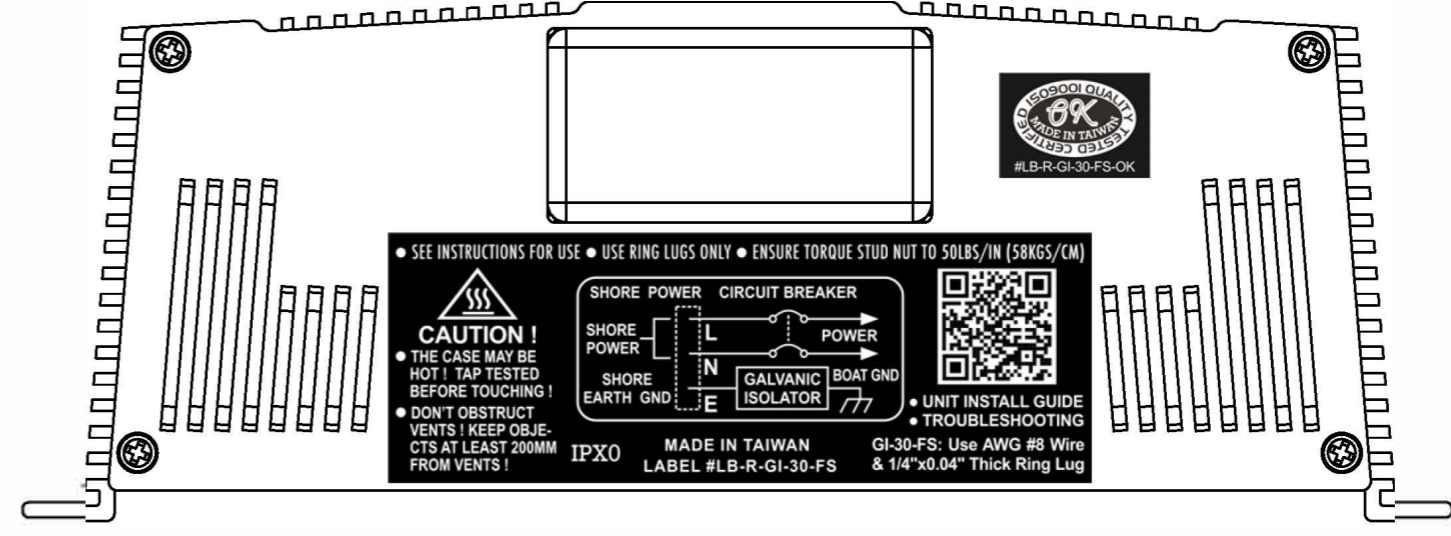

Fig. B) REAR PANEL VIEW

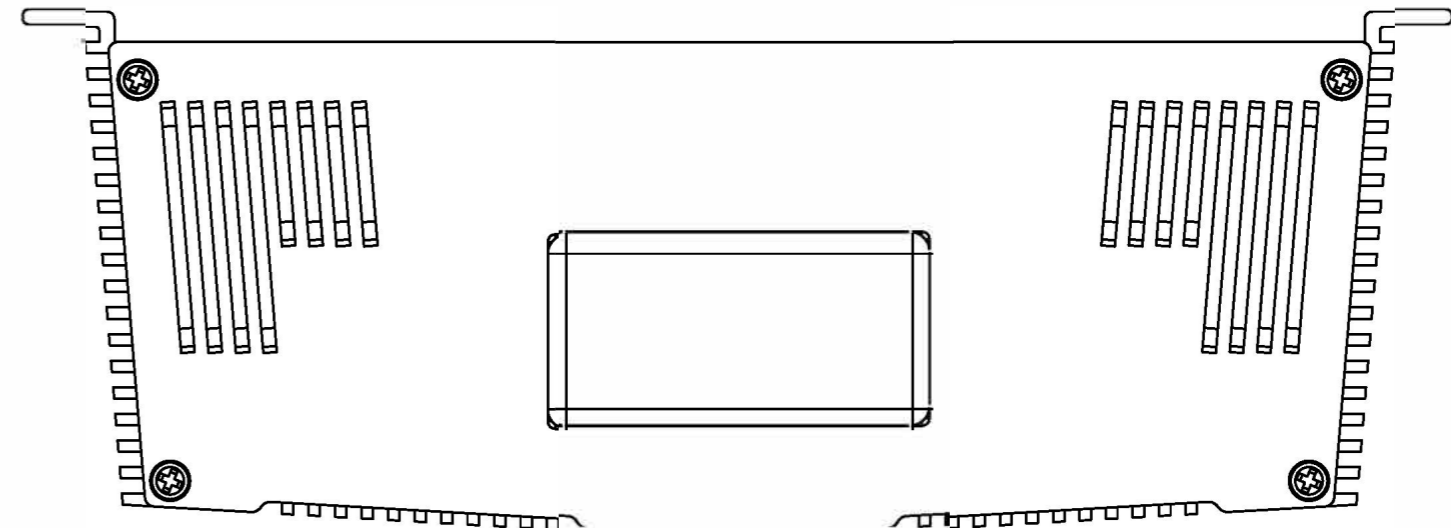

Fig. C) REAR VIEW

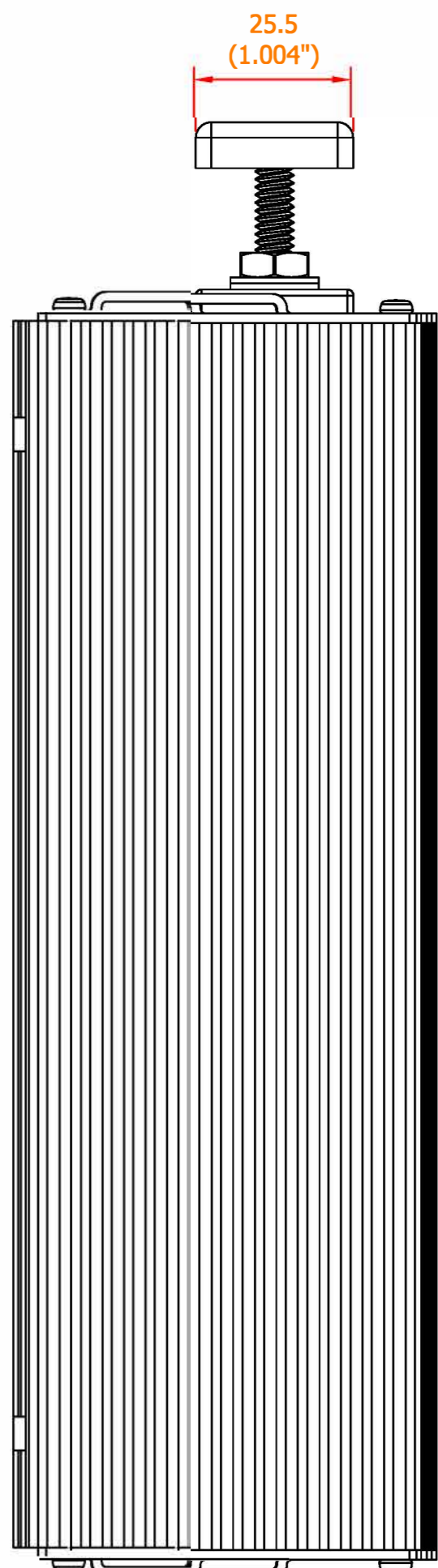
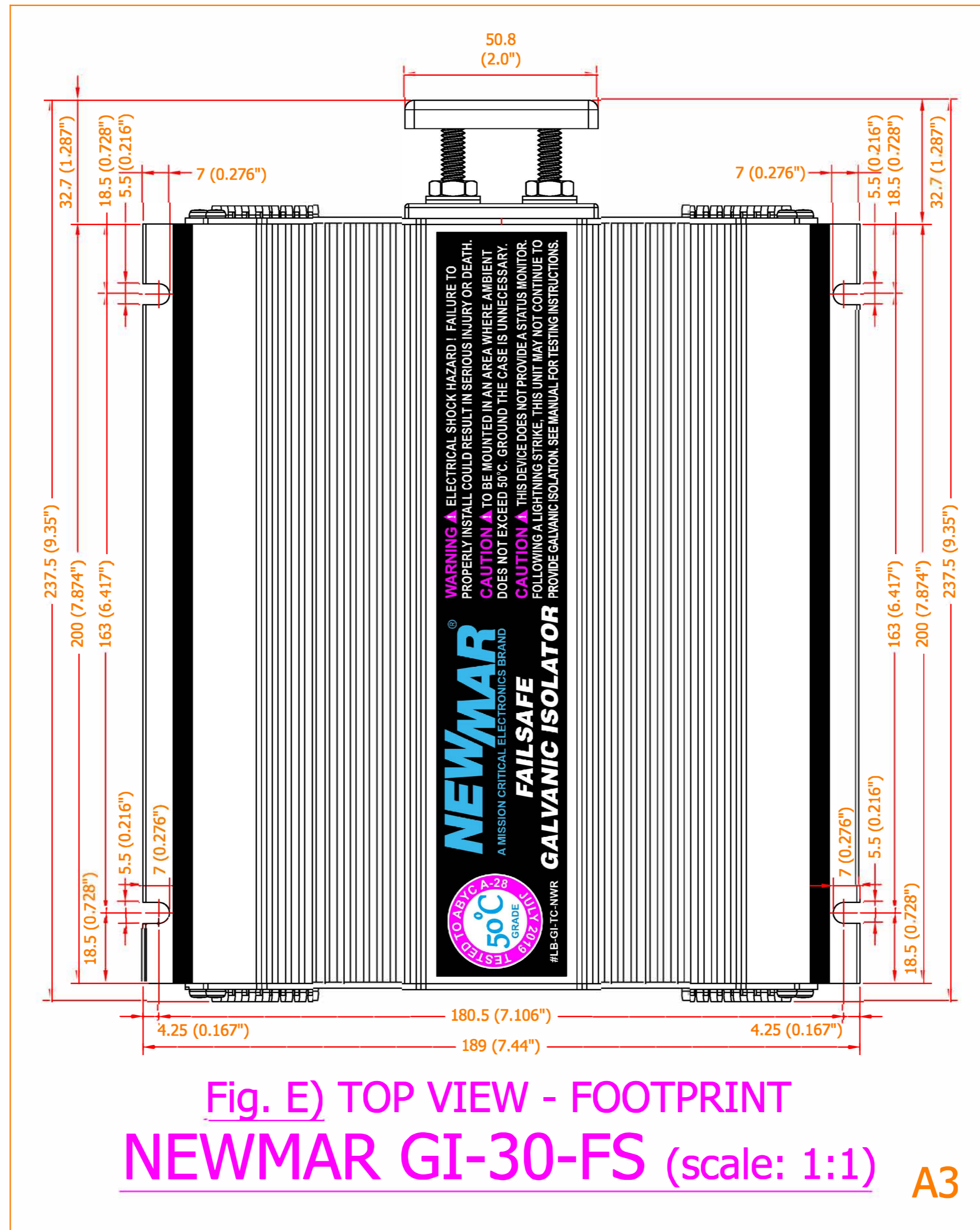

Fig. D) LEFT SIDE VIEW



**Fig. E) TOP VIEW - FOOTPRINT
NEWMAR GI-30-FS (scale: 1:1)**

A3

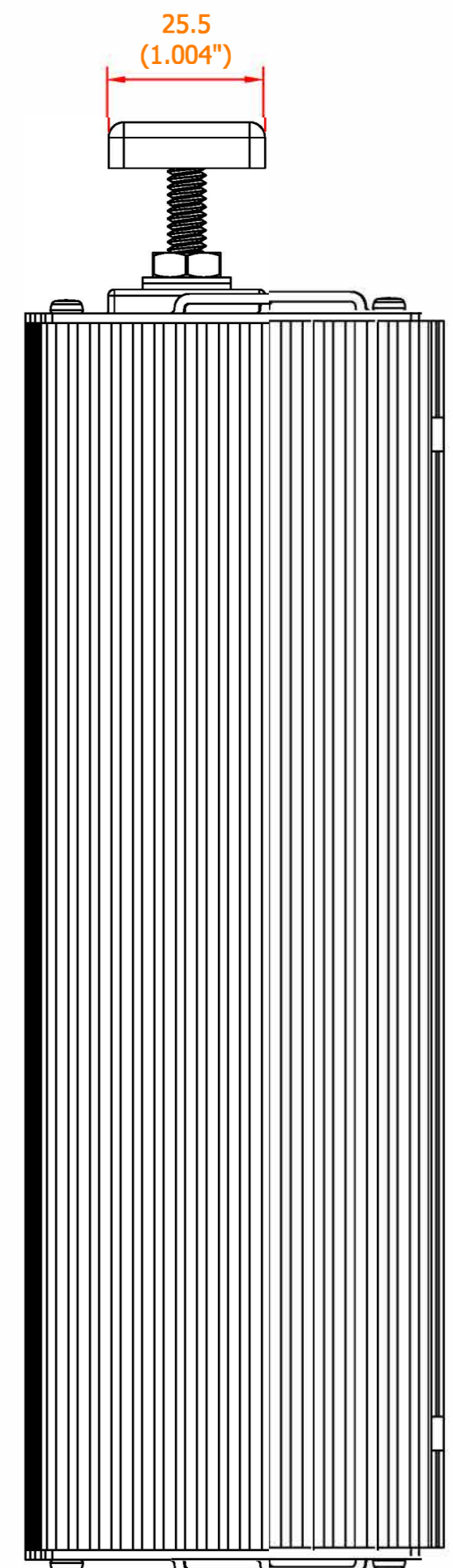

Fig. F) RIGHT SIDE VIEW



Fig. G) RIGHT FRONT VIEW

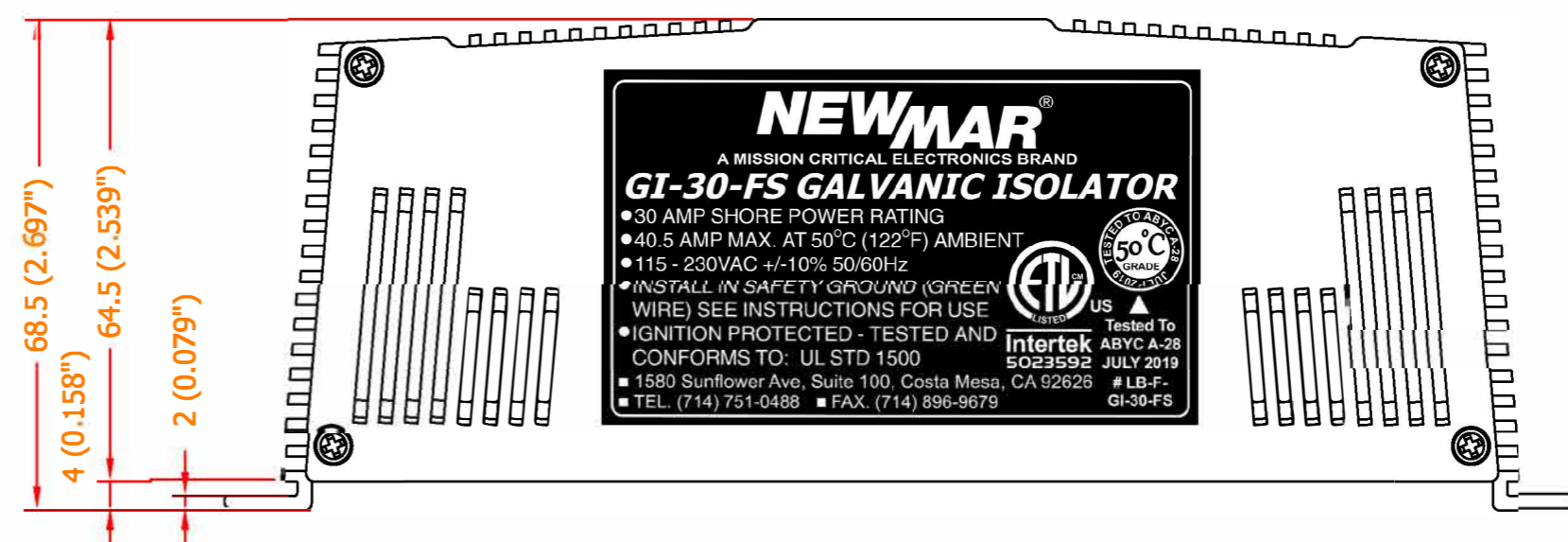

Fig. H) FRONT VIEW

TOLERANCES UNLESS OTHERWISE SPECIFIED DECIMAL PLACES		Title	
XXX = .01	XXX = .010	NEWMAR GI-30-FS-3D-ALL	
Drawn	Johnson 043023	Third Angle	Sheet of 1/1
Check	Johnson 043023	Unit	mm
Approval	Johnson 043023	Scale	1:1
		Sheet No.	GI-30-FS-3D-ALL
		DWG No.	GI-30-FS-3D-ALL
		Rev.	F