



Dye marker

Marine dye marker used for daytime emergency distress signalling and search and rescue marking.

A person in distress scatters the dye marker on the water when a potential rescue vessel or aircraft appears. It spreads as a brilliant spotting mark, clearly visible as a distress signal for up to an hour, and in good visibility can be seen by aircraft over 10 km away.

Ideal for boating, it is also an extra safety equipment for windsurfing, diving and snorkeling.

Sold in a sealed sachet with fastening lanyard.

Description	Ref.	Dimensions
40 g sachet + blister pack	38861	185 x 80 x 12 mm
40 g sachet + blister pack	301124	185 x 80 x 12 mm
80 g sachet.	301179	185 x 80 x 17 mm

Other size sachets available on request.

Flushmount safety ladder

51558

Helps any crewmember get back on board easily without external help.

Suitable for current use (bathing) or in case of Man Over Board.

Consists of 3 polypropylene steps and 1 st. steel handle assembled by a highly resistant line, (bright yellow Ø 3 mm polyester).

Ladder is stored in a polyamide tube with a grey polypropylene cap, for optimum protection and waterproofness.

The Man Over Board removes the cap, pulls the ladder down, and climbs onboard.

- Light.
- Very easy flush mount (like a thru-hull fitting).
- Transom or skirt mount (sail and power boats), just above waterline.



Safety ladder

- 4 steps : **29008**
- 5 steps : **29009**

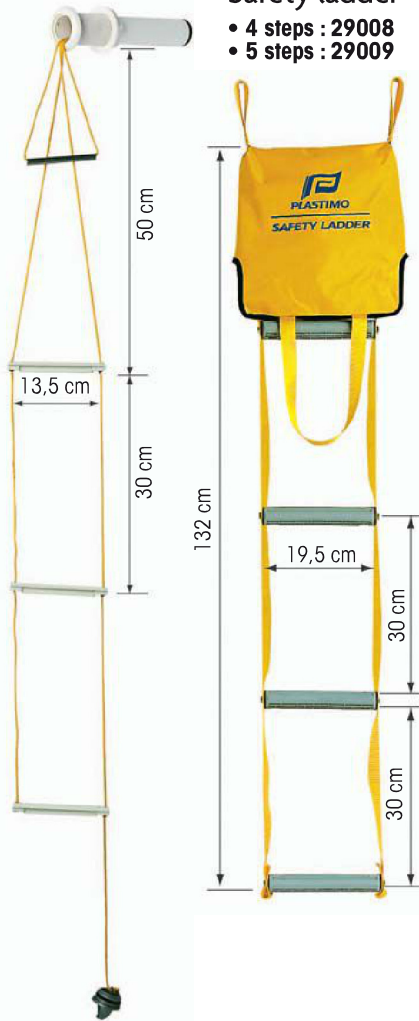

Designed to increase safety on board, this ladder comes in a canvas bag with 2 handles : one handle to attach the bag alongside the boat; the other handle for the man fallen overboard to grab. The bag pulls open and the ladder unfolds instantly, helping the person to get back on board easily.