

Item	Description	Qty.*	Repair Kit	Rebuild Kit
1	Pan Head Machine Screw	3	•	•
2	Top Plate	1	•	•
3	O-Ring	1	•	•
4	Viton Impeller	1	•	•
5	Seal	1	•	•
6	Seal Cover	1	•	•
7	Ball Bearing	1	•	•
8	End Cap Assembly	1		•
9	End Cap Screws O-Ring	2		•

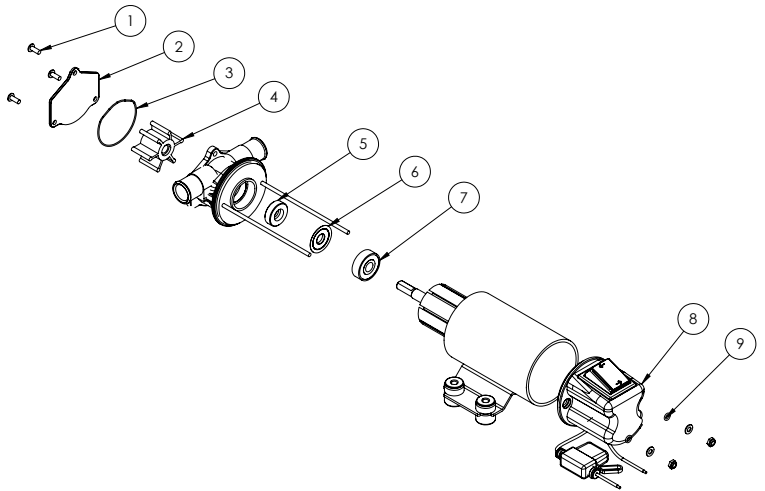

*Quantity x 2 when double kits are purchased.

Replacing the Impeller

Replace the impeller every season or after 500 hours of service. Impellers may require servicing earlier if the unit has been run dry, damaged by debris, or damaged by the use of incompatible fluids.

1. Remove the 3 screws securing the cover.
2. Remove cover plate and gasket.
3. Using your fingers, remove worn impeller.
4. Clean inside of pump head and remove any debris which will obstruct impeller's operation.
5. Apply lubricant to inside of pump head and to outside diameter of the impeller.
6. Align the flat section inside of the new impeller with the flat section of the motor shaft.
7. Place gasket on pump head, align holes, and replace cover plate.
8. Replace 3 screws and tighten evenly.

