

WINDSHIELD WIPER QUESTIONNAIRE

Contact Information

Name: _____

Company: _____

Address: _____

City: _____ State: _____ ZIP: _____

Tel: _____ Fax: _____

E-Mail: _____

Owner's Name: _____

Project Name: _____

Type of Application: _____

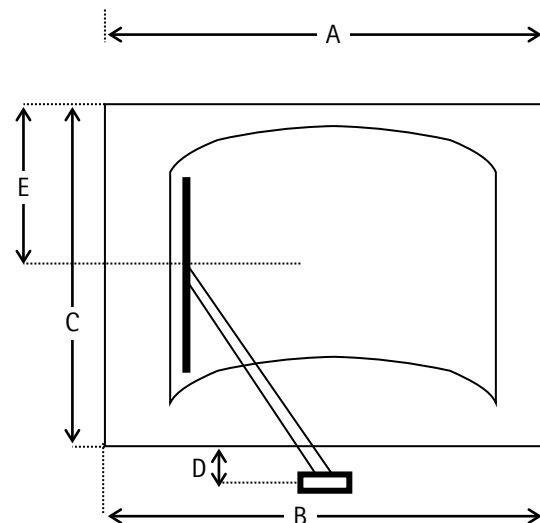

Motor Voltage & Location

- 12VDC
- 24VDC
- Below Window
- Above Window
- External

Switchgear Selection

- Electronic Control Panel (Synchronized)
- Electronic Wiper Switch (Synchronized)
- Individual Switch with Intermittent
- Individual Switch without Intermittent
- No Switchgear Needed

Washing System Details

- Complete System from Ship's Supply
- Complete System from Reservoir
- Bulkhead Mounted Jet
- Arm Mounted Jet
- No System Required

Window Type:



Note: Straight Line Wiper Systems are available, please note window height and width dimensions in comment field below for recommendations.

Window Dimensions

	Port	Port/Center	Center	Starboard/Ctr	Starboard
Window Type (see above)					
Window Height [C]					
Width of Glass/Top [A]					
Width of Glass/Bottom [B]					
Motor Setback* from Window [D]					
Eye Level [E]					
Bulkhead Thickness					

* The "Motor Setback from Window" is the distance between the inside edge of the windshield frame and the center of the motor shaft

* Please take into account the radius of any corner when measuring window dimensions.

Please check if wiper motor mounting position is not parallel with windshield. If known, what is the angle between them: _____

Additional Comments/Sketch:



C O R P O R A T I O N