



ROCA[®]

WIPER MOTOR | W50

Installation Instructions

Before installation please read these instructions.

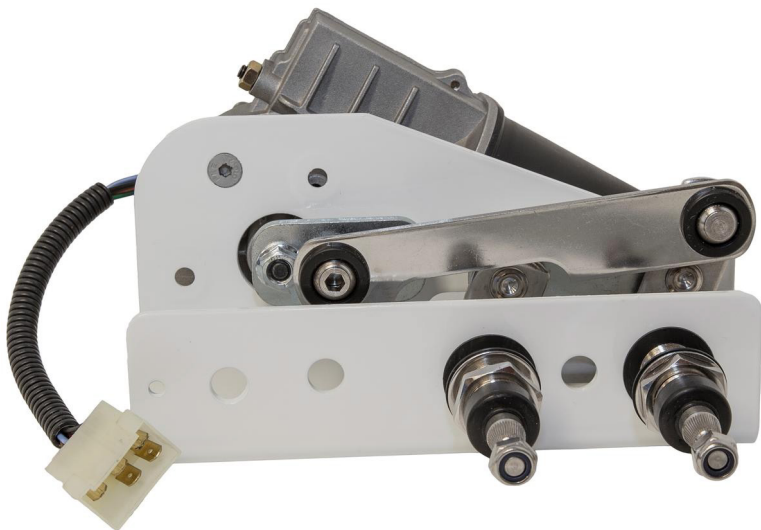

- 2 Speed, self-parking
- Heavy Duty motor, 50Nm
- Wipershaft in stainless steel
- Various sweep angle: 45 - 110°
- Dynamic park circuit
- Internal thermostitch
- Insulated ground
- EMC protected
- Powers up to 1200mm/1200mm - Arm/blade combinations

Instructions - Adjusting the sweep angle and parking position

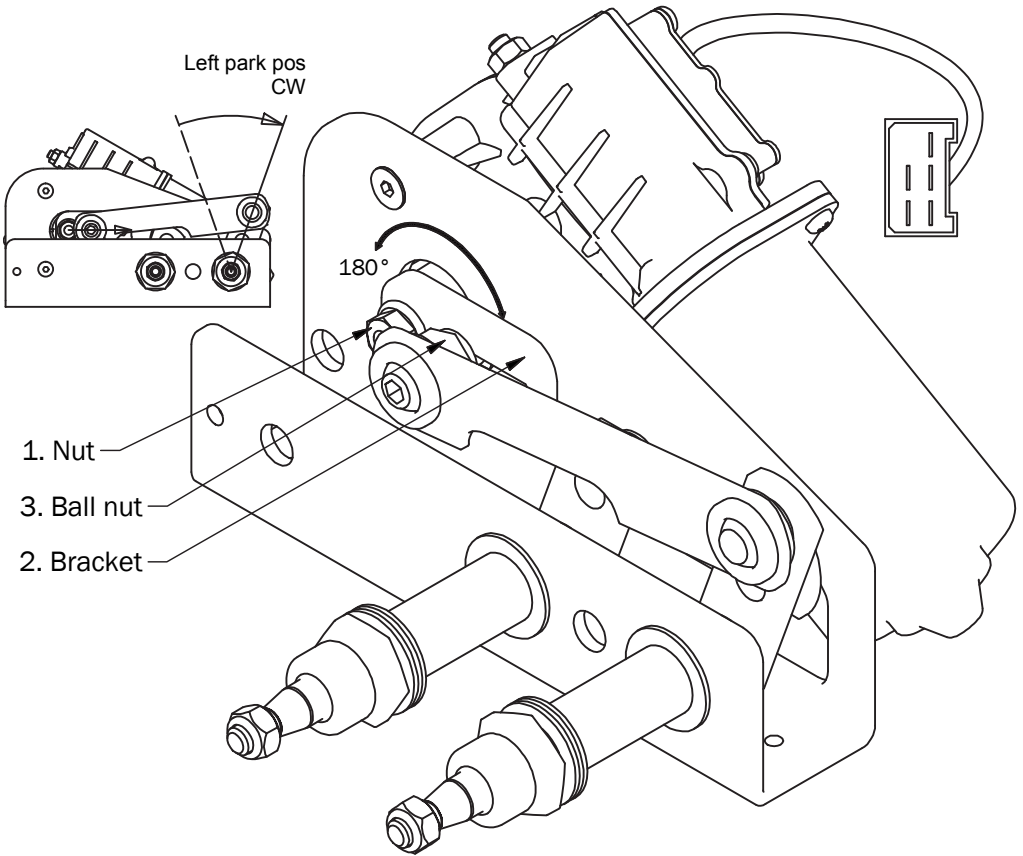

Changing the parking position.

Before the parking position is changed, the wiper motor should be in parked position (Default is set to left).

Keep battery main switch turned off during any operation inside of the wiper motor.

- **Loosen the nut (1).**
- **Remove the bracket (2) and rotate it 180°.**
- **Assemble the bracket and tighten the nut firmly.**

Change of wiped angle.

The wiped angle can be set at any point between 45° and 110°.
(Default is set to 45°).

Keep battery main switch turned off during any operation inside of the wiper motor.

- **Loosen the ball/nut (3).**
- **Move the ball/nut to desired angle position and tighten it firmly.**

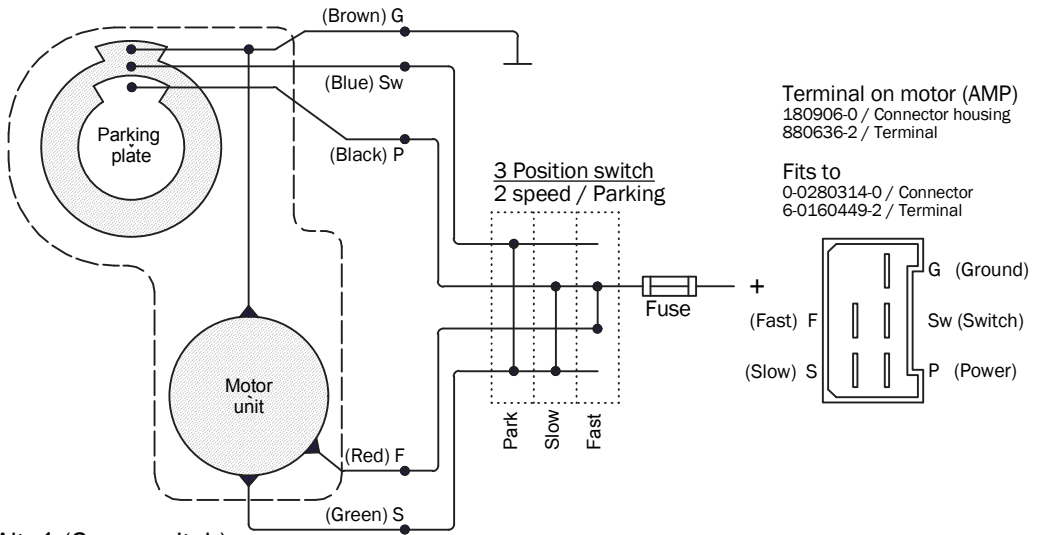

Alt. 1 (3 pos.switch)

Alt. 2 (Roca switch)

Actuator
466026

Switch
466221 / 12V
466222 / 24V

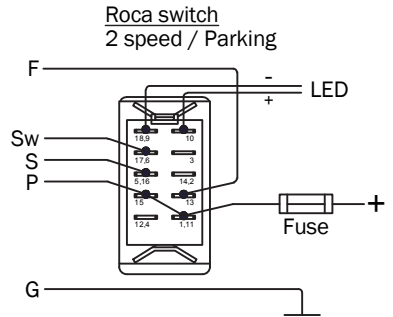
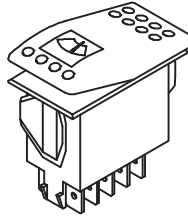

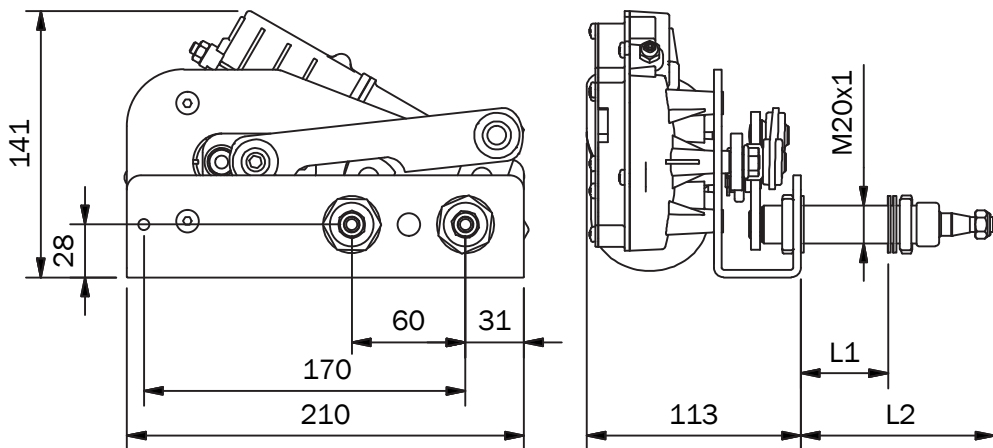

Variations:

Max length:		Voltage input:	
L1	L2	12 V	24 V
28	78	531013	531014
53	103	531023	531024
78	128	531033	531034

Current diagram:	12 V	24 V
No load	< 6 A	< 3 A
Normal running	< 10 A	< 5 A
Stall	< 40 A	< 20 A
Fuse	40 A	20 A

Limited warranty

- Roca warrants the wiper motors to be free from defective material and workmanship for a period of 3 years from the date of purchase.
- This warranty does not apply to failure or damage caused by improper installation, misuse, lightning strike or damage from a power surge.
- If failure occurs during this period, return it to your dealer for repair or replacement.

Wiper arms and blades:



Pantograph
536335 EP
538335 Black



Pantograph
536347 EP
538347 Black



Blade (28"- 40")
520828 - 40