



---

# Fully Automatic Bilge Pump

## INSTRUCTION MANUAL

---

- FR** Pompe de cale entièrement automatique
- DE** Vollautomatische Bilgenpumpe
- IT** Pompa di sentina completamente automatica
- NL** Volautomatische lenspomp
- SE** Helt automatisk länsypump
- ES** Bomba de achique totalmente automática



## Purpose of this manual

The purpose of this manual is to provide necessary information for product installation, operation and maintenance.



**CAUTION:** Read this manual carefully before installing, using or servicing this product. Failure to follow the instructions within this manual could result in explosion, property damage, severe personal injury and/or death.

---

## User safety

**General safety rules.** These are safety rules that apply:

- Always keep work area clean
- Pay attention to the risks presented by gas and vapors in the work area.
- Avoid all electrical dangers. Pay attention to the risks of electric shock or arc flash hazards
- Always bear in mind the risk of drowning, electrical accidents and burn injuries



**DANGER:** This product is not intended for damage control or to deal with flooding resulting from hull damage. This product is intended to be used in Bilge Pumping Systems for small craft with a hull length up to 24 meters, as described within the introduction and scope of ISO 15083. Bilge Pumping Systems, as specified in ISO 15083, are limited to normal amounts of water in an intact boat due to spray, rain, seepage, spillage, and occasional small amounts of water shipped from boat movements in heavy weather. Use of product in any other way could result in flooding, catastrophic damage to craft, serious personal injury, or death.

---



**WARNING:** This pump is designed for use with fresh water and salt water ONLY. Use with any other hazardous, caustic, or corrosive material could result in damage to the pump and the surrounding environment, possible exposure to hazardous substances and injury.

---

Bilge pumps shall be mounted in accordance with the pump manufacturer instructions, and in an accessible location to permit servicing and cleaning of the intake and/or screening.

On boats with an enclosed accommodation compartment, an audible alarm shall be installed indicating that the bilge water is approaching the maximum bilge water level.

Bulkhead penetrations shall be in accordance with the requirements of ABYC H-2, Ventilation of Boats Using Gasoline, to minimize the potential for migration of carbon monoxide from machinery compartments containing gasoline engines to adjacent accommodation compartments.

Potential electrical sources of ignition located in spaces containing gasoline powered machinery, or gasoline fuel tank(s), or joint fitting(s), or other connection(s) between components of a gasoline system, shall be ignition protected, unless the component is isolated from a gasoline fuel source as described in ABYC E-11.5.3.3

**Exception:**

1. Boats using diesel fuel as the only fuel source.
2. Outboard engines mounted externally or in compartments open to the atmosphere in accordance with the requirements of ABYC H-2, Ventilation of Boats Using Gasoline.

The bilge pump inlet shall be located so that excess bilge water can be removed from the bilge at static floating position, and at maximum conditions created by the boat's motion, heel, and trim.

## Electrical

Disconnect power before installing or servicing the pump.

Our pump is equipped with silicone blocked, tin coated 16 gauge wire. Please follow the table below when extending the wires.

### Wire Size Table

Total Wire Length (positive to pump) - feet (meters)

0-15 ft 0-4.5 m	15 - 20 ft (4.5 - 6 m)	20 - 30 ft (6 - 9 m)	30 - 60 ft (9 - 18 m)	60 - 90 ft (18 - 27 m)
16 AWG (1.5 mm <sup>2</sup> )	14 AWG (2.5 mm <sup>2</sup> )	12 AWG (4 mm <sup>2</sup> )	10 AWG (6 mm <sup>2</sup> )	8 AWG (10 mm <sup>2</sup> )

### This pump must be fused with a 7.5 amp fuse (not included).

All potential sources of ignition located in spaces containing gasoline powered machinery or gasoline fuel tank(s), or joint fitting(s), or other connection(s), between components of a gasoline system, shall be ignition protected in accordance with the requirements of ABYC E-11, AC and DC Electrical Systems On Boats.

The electrical wiring, connections, and installation shall be in accordance with the requirements of ABYC E-11, AC and DC Electrical Systems On Boats.

The following is a summary of typical wiring installations:

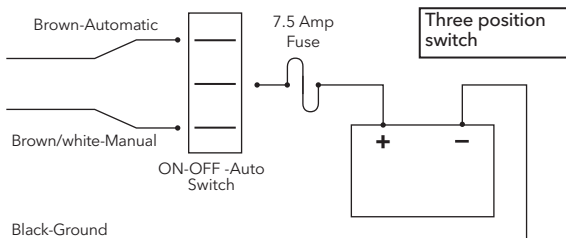
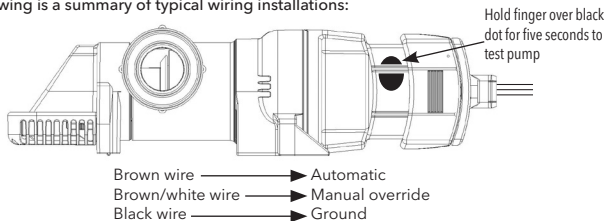

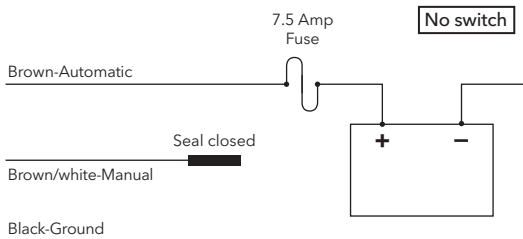
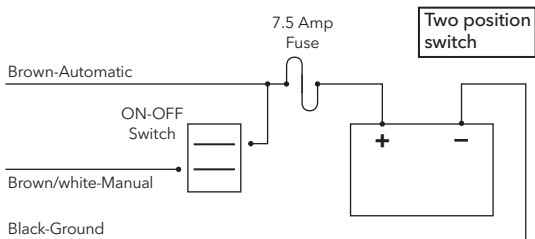

Pumps with automatic controls shall be provided with a visual indication that power is being supplied to the pump.

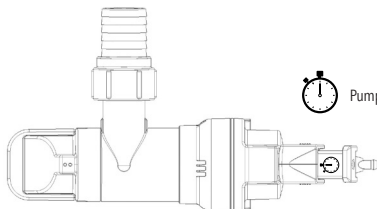

Pump will cycle every 2.5 minutes to sense for water.

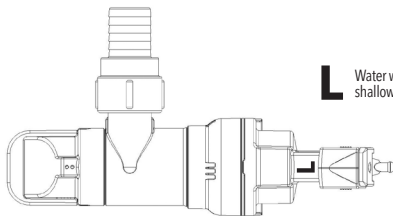

Water will reach approx 1.3" (3.3 cm). Good for shallow bilges and small compartments.

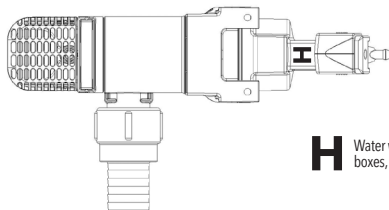

Water will reach approx 2" (5 cm). Good for shower boxes, very wet areas, narrow bilges.

## Installation:

We recommend using #8 Stainless Steel screws of an adequate length as to secure the pump but not penetrate the entire thickness of the hull. Use a flexible sealant in the screw holes to prevent water from penetrating the screw holes.

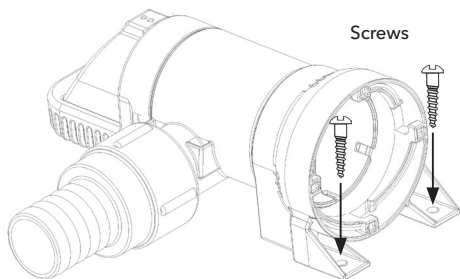
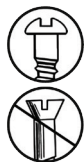
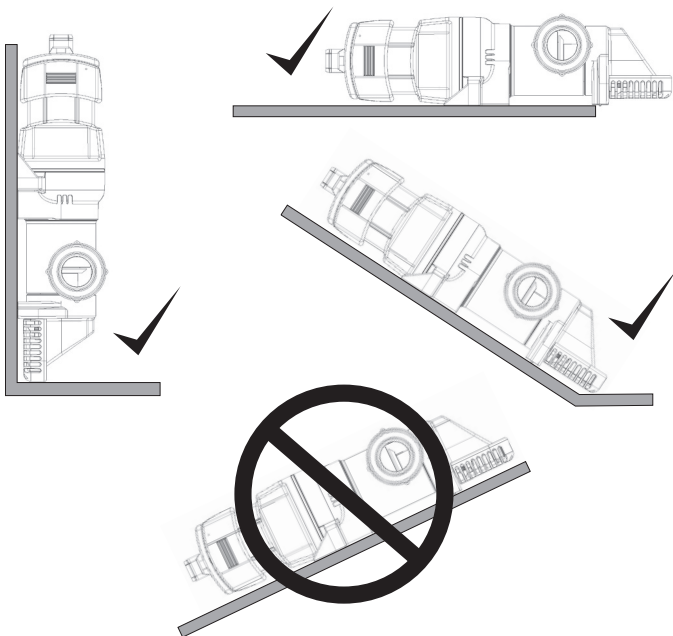

## Disassembly and reassembly

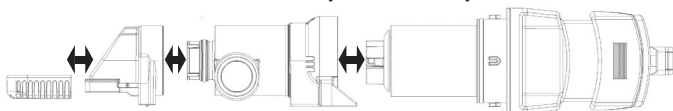

Best practice: Periodically clean the sensor housing with a mild detergent to remove any build-up that may interfere with the proper operation of the bilge pump. If the sensor accumulates excessive build-up, the pump will enter the timer mode to protect the pump and the vessels batteries. Once the debris is removed, the pump will return to level sense mode.

## Plumbing:

This bilge pump has been designed to be used with flexible hose. Rigid piping or tubing may damage the pump or the pump's discharge.

Factors that reduce the flow of a bilge pump may include but are not limited to the following:

- The length of discharge piping (longer runs reduce flow)
- The number or radius of bends
- The roughness of the interior surfaces of piping and fittings (smooth bore hose is best)
- The reduction (hose restriction) in cross-sectional area of discharge system components such as check valves and thru-hulls

Attach the discharge hose to the hose barb using stainless steel hose clamps.

The thru-hull discharge fitting should be mounted at least 8" (20.3 cm) above the heeled water line to prevent water siphoning in from outside the vessel or the discharge may be located below the maximum heeled waterline if the discharge line is provided with both of the following:

- A seacock installed in accordance with the requirements of ABYC H-27, Seacocks, Thru-Hull Connections, and Drain Plugs, and
- A vented loop or other means to prevent siphoning into the boat. A check valve shall not be used for this purpose.

If the discharges of several pumps are manifolded to discharge through a single thru-hull fitting, the system shall be designed so that the operation of one pump will not back feed another pump, and the simultaneous operation of each pump will not diminish the pumping capacity of the system. A check valve shall not be used in the discharge manifold system.

A check valve may be used only when necessary to prevent an automatic bilge pump from cycling on and off due to back flow from the discharge line.

Hose connections shall be secured with a non-corrosive type of clamp, or be mechanically fastened with permanently-attached end fittings, such as swaged sleeve. Threaded inserts shall be attached with corrosion resistant metallic clamps.

Best practice: Use two stainless steel hose clamps to attach hose to hose barb.

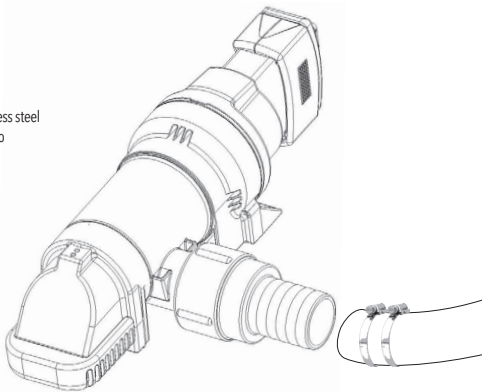

During the winterization of a vessel, it's recommended that you remove the check valve (if equipped) and drain any residual water from the plumbing.

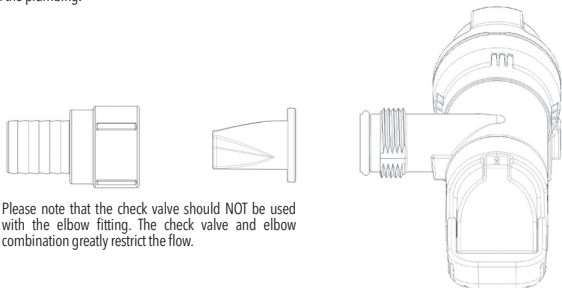

Please note that the check valve should NOT be used with the elbow fitting. The check valve and elbow combination greatly restrict the flow.

# Dimensional Drawing

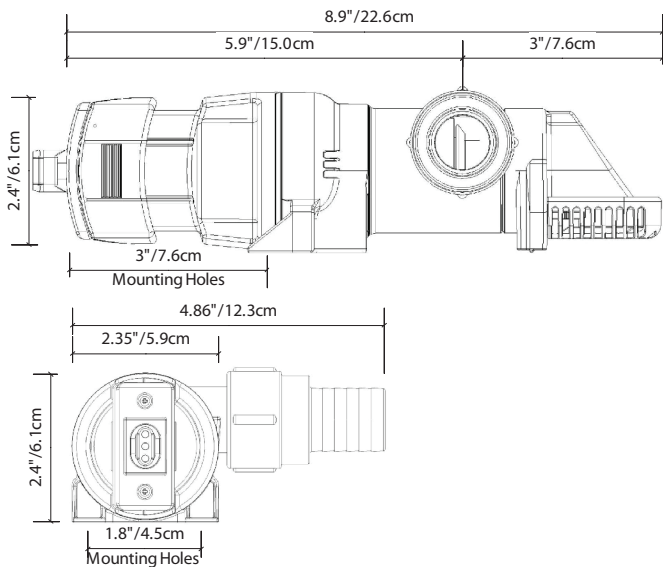

# Flow Curves

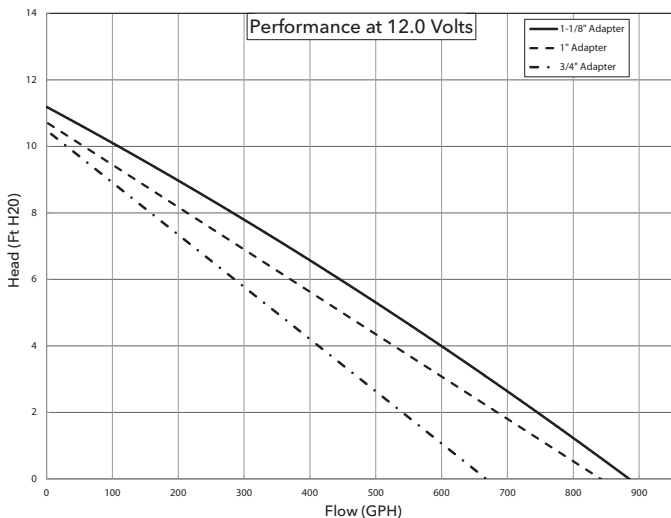

---

All mounting holes must be sealed with a marine grade sealant to prevent water intrusion.



**ABYC**  
*Setting Standards for Safer Boating*  
Install to ABYC  
H-22 and E-11

---

**CE** We hereby declare, under our sole responsibility, that our product to which this declaration relates has been designed to comply in accordance with the following Directives:

Electromagnetic Compatibility Directive 2004/108/EC  
Recreational Craft Directive 2003/44/EC  
RoHS 2011/65/EU. Regulation No. 1907/2006

With the relevant selections of the following Standards:

ISO 8846:1990 / Ignition Protection  
ISO 8849:2003 / Electrically Operated DC Bilge Pumps  
ISO 10133:2012 / Extra Low Voltage D.C. Installations  
ISO 15083:2003 / Bilge Pumping Systems

This product is intended to be used in Bilge Pumping Systems for small craft with a hull length up to 24 meters, as described within the introduction and scope of ISO 15083. Install following the Provisions of the Recreation Craft Directives 2003/44/EC.

---