

MARINE PRODUCT DATA SHEET

OEM: 3200-000 (Macerator Pump)
AFTERMARKET: 3200-001 (Macerator Pump)

APPLICATION

12V DC Macerator Pump Designed specifically for sanitation waste and fish box evacuation



PUMP:

Type: Centrifugal Pump (Flex-Impeller)
 Inlet Port: 1-1/2" Barb / 1-1/2" NPT
 Outlet Port: 1" Barb
 Liquid: 130 °F [54 °C] Max
 Dry-Prime: 4 feet [1.21 M]
 Inlet PSI: 30 PSI [2.1 Bar] Max
 Run Dry: Yes (three (3) minutes max).



Designed specifically for sanitation waste and fish box evacuation, SHURflo's Macerator pump features a premium impeller design with run-dry capability and includes our seamless shell e-coated motor with o-ring sealed and bells and sealed manual turn key. SHURflo's unique dual blade and housing construction ensures problem free pumping, providing superior performance in harsh marine environments.

ELECTRICAL:

Motor: 12VDC Permanent Magnet, Intermittent Duty
 Protection: Thermal Overload, Automatic Restart
 Leads: 14 AWG, 17.5" [44 cm] Red +, 18.5" [47 cm] Black -
 Fuse: 25 Amp Recommended
 Control: No Control

MATERIALS:

Housing: Phenolic - Nylon
 Impeller: Polyurethane
 Hardware: Stainless Steel

APPROVALS:

Ignition Protection 8846, CE

WARRANTY:

1 Year Limited Warranty.
 Contact SHURflo for details

SHIPPING:

Net Weight (boxed): 6 Lbs [2.7 Kg] each
 Carton Quantity: 6
 Carton Weight: 36 Lb [16.3 Kg]
 Approx. Carton Size: 24"L x 18"W x 6"H [60.9cm x 45.7cm x 15.2cm]

RELATED DOCUMENTS:

Catalog: MS-030-140
 Installation Manual: 911-566
 Applications Spec Guide: MS-020-005

Replacement Kits

Number	Description	Part Number
1	Impeller Kit	94-571-00
2	Impeller Housing kit	94-570-00
3	Gasket Kit	94-570-01 (10 pcs)
4	Cutter Blade Kit	94-570-02
5	Impeller Kit	94-570-03 (10 pcs)
6	Lip Seal Kit	94-570-04

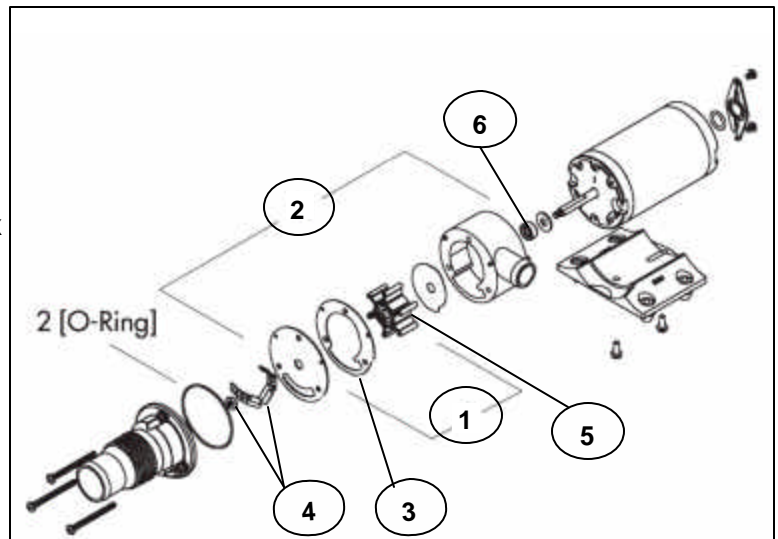

TYPICAL PERFORMANCE

PRESSURE		FLOW		CURRENT
BAR	PSI	GPM	LPM	AMPS
0.0	0	13	49.2	13.8
0.27	4	8	30.3	14.5
0.55	8	6	22.7	16.1
0.82	12	4	15.1	16.8
1.10	16	0.0	0.0	17.0

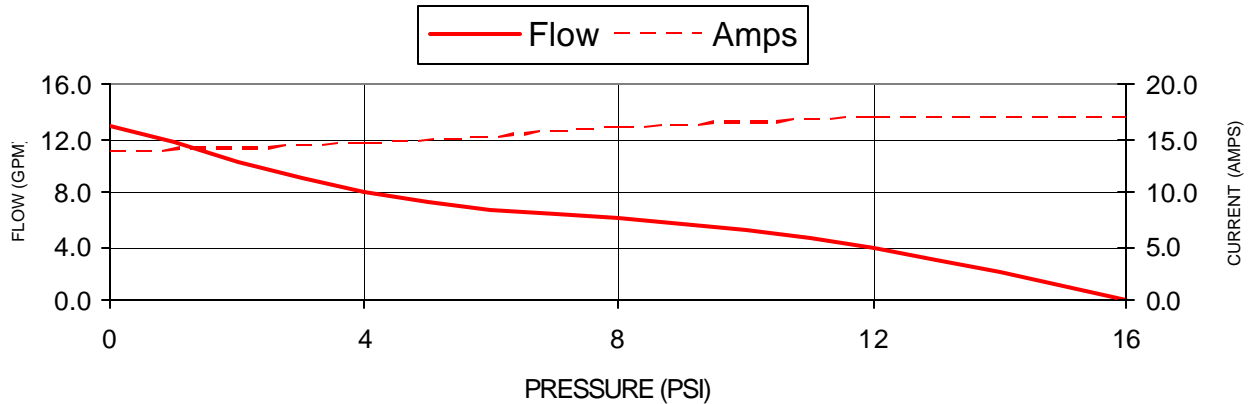

DIMENSIONS [mm]

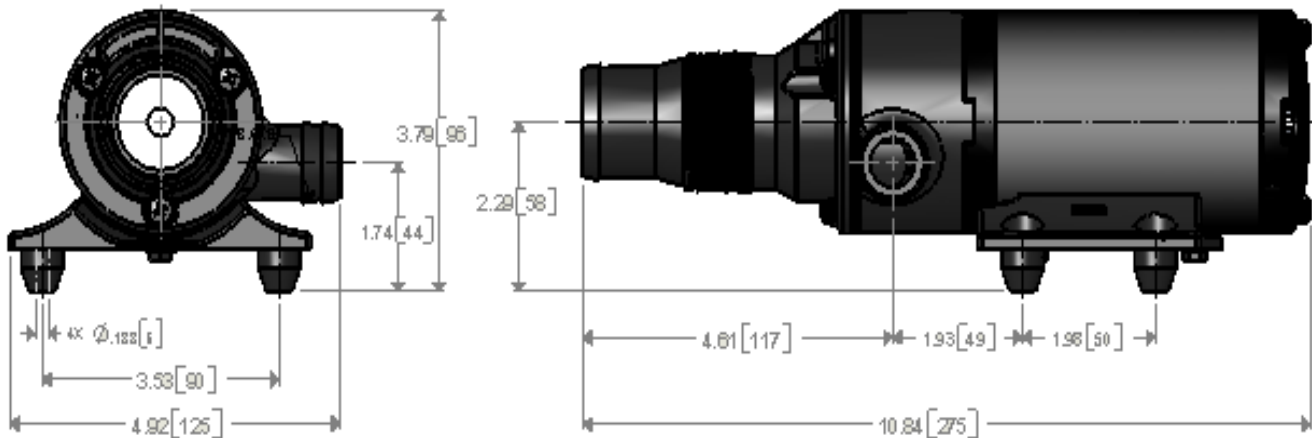

Visit our Web Site at <http://www.shurflo.com>
 Shurflo reserves the right to update specifications,
 change prices, or make substitutions without notice.

SHURflo
 5900 Katella Avenue
 Cypress, CA 90630
 Phone (562) 795-5200
 Toll Free (800) 854-3218
 Fax (562) 795-7564

SHURflo East
 52748 Park Six Court
 Elkhart, IN 46514-5427
 Phone (562) 795-5200
 Toll Free (800) 854-3218
 Fax (574) 264-2169

SHURflo Europe, Middle East, Africa
Pentair Water Belgium bvba
 Industriepark Wolfstee, Toekomstlaan 30
 B-2200 Herentals, Belgium
 Phone +32-14-283500
 Fax +32-14-283505



Pentair Water
FLOW TECHNOLOGIES GROUP
 5900 Katella Ave, Cypress, CA 90630
 Phone (800) 854-3218 • (562) 795-5200 • Fax (562) 795-7564
www.shurflo.com