

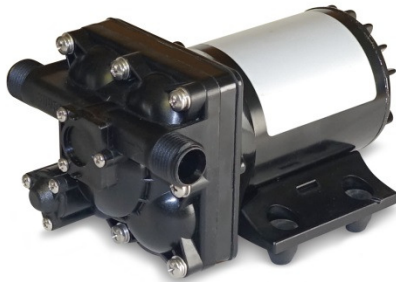

SHURFLO MARINE DUTY PUMP

AIR CONDITIONING REFRIGERATION CIRCULATION – PRODUCT TECHNICAL DATA SHEET

OEM: 4728-110-E10
 AFTERMARKET: 4728-110-E10



APPLICATION:

Air conditioning / Refrigeration circulation.
 This pump may be used for general fresh water transfer

PUMP DESIGN:

Type: 4 Chamber Diaphragm pump
 Ports: 1/2"-14 NPSM-Male
 Liquid: 130°F [54°C] Max
 Dry-Prime: 4 feet [1.2 M]
 Run Dry: Yes
 Inlet Pressure: 30 PSI Max. [2.06 Bar]

ELECTRICAL:

Motor: 12V DC Permanent Magnet, Continuous Duty.
 Protection: Thermal Overload, Automatic Restart
 Leads: Black - 14 AWG, 13" [33 cm] Red – 14 AWG 14" [35 cm]
 Fuse: 5 Amp Recommended
 Control: Internal By-Pass: 40 PSI Max (2.8 Bar)

MATERIALS OF CONSTRUCTION:

Housings: Polypro
 Valves/Seals: EPDM
 Diaphragm: Santoprene
 Hardware: Stainless Steel

AGENCY APPROVALS:

Ignition Protection 8846, CE, IMCI Certified

SHIPPING INFORMATION:

Approx. Net Weight: 5.0 Pounds [2.2 Kg] ea.
 Carton Qty.: 6
 Approx. Carton Weight: 33 Lbs. [15 Kg]
 Approx. Carton Size: 24"L X 18"W X 6"H [61cm x 46cm x 15cm]

REPAIR KITS

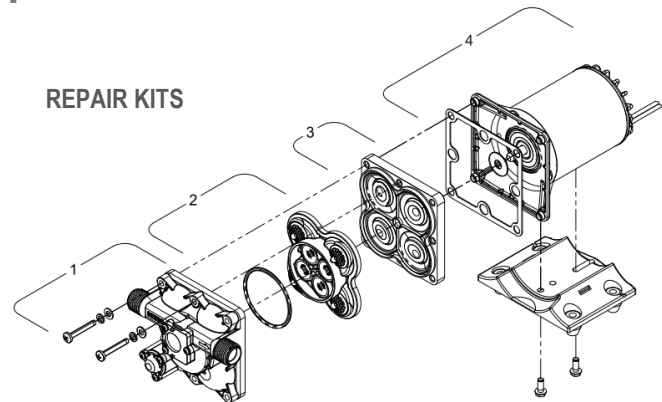

Number	Description	Part Number
1	Upper Assembly	94-800-31
2	Valve Assembly	94-800-01
3	Drive Assembly	94-800-25
4	Motor/Gasket	94-71-007-07
Not Shown	Check Valve	94-800-03

RELATED DOCUMENTS:

Catalog: MS-030-140
 App Guide Sheet MS-020-005
 Installation Manual: 911-1054
 Retail Warranty: 911-1045

TYPICAL PERFORMANCE AT 12V

PRESSURE		FLOW		CURRENT
BAR	PSI	GPM	LPM	AMPS
0	0	2.0	7.6	1.4
0.7	10	1.4	5.3	2.0
1.4	20	1.1	4.2	2.5
2.1	30	0.5	3.0	2.9
2.8	40	0.0	0.0	2.8

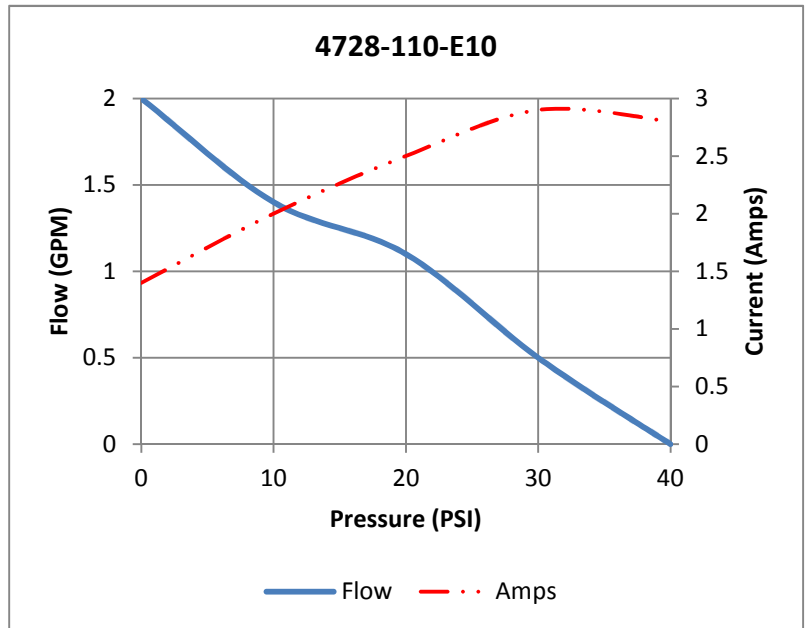

DIMENSIONS:

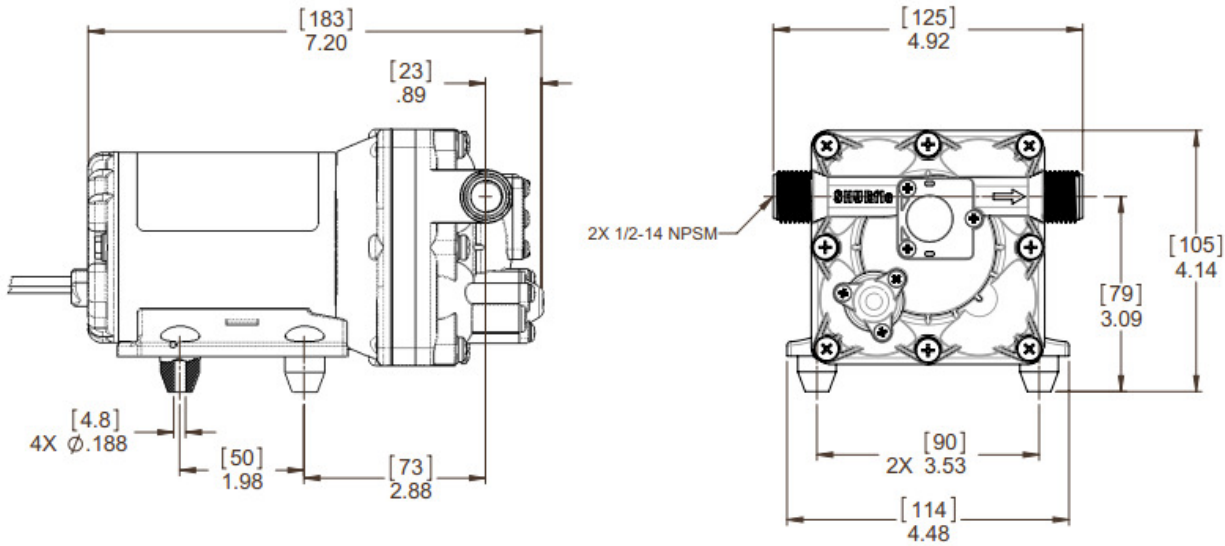

FLOW MANAGEMENT SOLUTION

3545 Harbor Gateway South, Suite 103, Costa Mesa, CA 92626, (800) 854-3218 www.SHURFLO.com

All Pentair trademarks and logos are owned by Pentair, Inc. All other brand or product names are trademarks or registered marks of their respective owners. Because we are continuously improving our products and services, Pentair reserves the right to change specifications without prior notice. Pentair is an equal opportunity employer.