

# ® **SIDE- POWER**

## **Stern thruster installation manual**

Keep this  
manual onboard!

### **IMPORTANT NOTICE:**

*This manual is to be used in addition to the regular installation manual for the Sidepower thruster. This manual is intended for professionals only, and does not contain all detailed work instructions for what must be done to ensure correct and safe installation of the sternthruster.*



### **SLEIPNER MOTOR AS**

P.O. Box 519  
N-1612 Fredrikstad  
Norway  
Tel: +47 69 30 00 60  
Fax: +47 69 30 00 70

[www.side-power.com](http://www.side-power.com)  
[sidepower@sleipner.no](mailto:sidepower@sleipner.no)



Made in Norway

# Installation

To achieve maximum effect, reliability and durability from your Sidepower Sternthruster, a correct installation is very important.

Please follow the instructions carefully, and make sure that all checkpoints are carefully controlled.

1. Make sure that there are enough space both inside and outside the transom of the boat (see FIG 1).

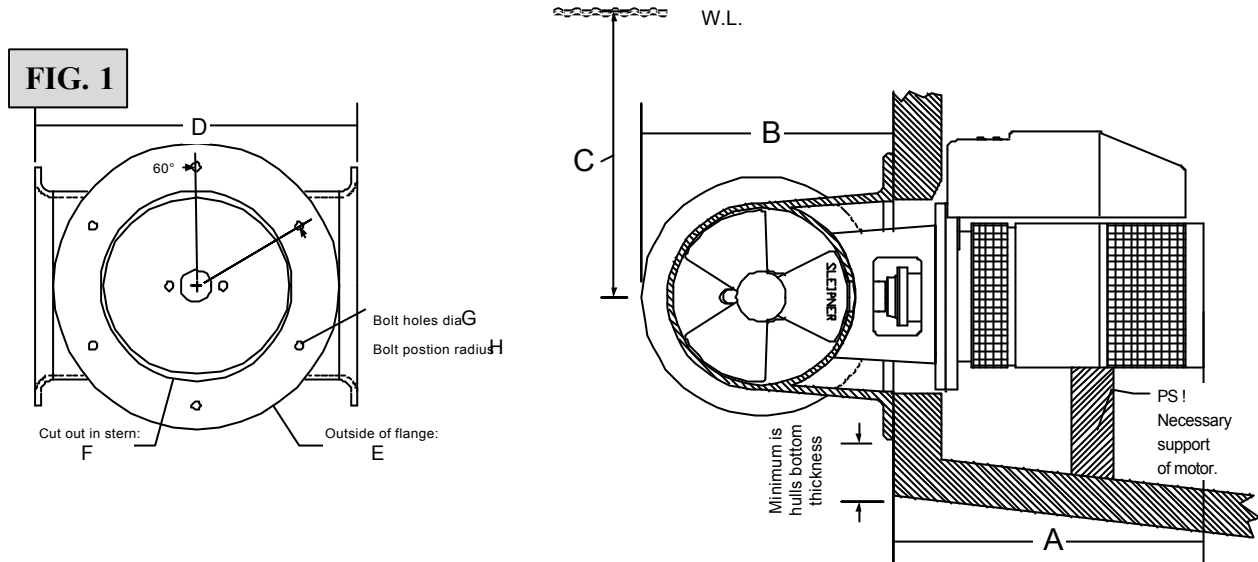

Measurements mm/inch	SE30/40	SE60	SE80	SE100	SE120/SE150	SE130	SE170	SE210	SP200TCi-32/ SP240TCi	SP285TCi
A	200mm/7.87"	225mm/8.90"	312mm/12.30"	349mm/13.70"	407mm/16.02"	363mm/15.10"	386mm/15.20"	419mm/16.50"	440mm/17.30"	404mm/15.90"
B	190mm/7.48"	265mm/10.08"	256mm/10.08"	256mm/10.08"	300mm/11.81"	340mm/13.39"	340mm/13.39"	360mm/14.20"	420mm/16.54"	420mm/16.54"
C	135mm/5.31"	150mm/5.91"	200mm/7.87"	200mm/7.87"	215mm/7.87"	250mm/9.54"	250mm/9.54"	300mm/11.80"	300mm/11.81"	300mm/11.81"
D	197mm/7.76"	337mm/13.30"	337mm/13.30"	337mm/13.30"	330mm/13.00"	350mm/13.80"	350mm/13.80"	350mm/13.80"	456mm/18.00"	456mm/18.00"
E	ø217mm/8.54"	ø300mm/11.81"	ø300mm/11.81"	ø300mm/11.81"	ø300mm/11.81"	ø300mm/11.81"	ø300mm/11.81"	ø356mm/14.02"	ø396mm/15.60"	ø396mm/15.60"
F	ø160mm/6.3"	ø200mm/7.84"	ø200mm/7.84"	ø200mm/7.84"	ø200mm/7.84"	ø200mm/7.84"	ø200mm/7.84"	ø260mm/11.24"	ø265mm/11.40"	ø265mm/11.40"
G	6 x ø6,5mm/0.26"	6 x ø10,5mm/0.41"	6 x ø10,5mm/0.41"	6 x ø10,5mm/0.41"	6 x ø10,5mm/0.41"	6 x ø10,5mm/0.41"	6 x ø10,5mm/0.41"	8 x ø10,5mm/0.41"	8 x ø10,5mm/0.41"	8 x ø10,5mm/0.41"
H	ø98mm/3.36"	ø129mm/5.08"	ø129mm/5.08"	ø129mm/5.08"	ø129mm/5.08"	ø129mm/5.08"	ø129mm/5.08"	ø315mm/12.40"	ø345,6/13.60"	ø345,6/13.60"
Max stern thickness	14mm/0.55"	35mm/1.38"	54mm/2.13"	54mm/2.13"	54mm/2.13"	60mm/2.36"	60mm/2.36"	50mm/1.97"	60mm/2.36"	60mm/2.36"

Measurements mm/inch	SH100	SH160	SH240	SP300HYD	SH420	SH550
A	172mm/6.72"	172mm/6.72"	191mm/7.52"	195mm/7.68"	257mm/10.12"	257mm/10.12"
B	256mm/10.08"	300mm/11.81"	340mm/13.39"	420mm/16.54"	570mm/22.44"	570mm/22.44"
C	200mm/7.87"	215mm/7.87"	300mm/11.81"	300mm/11.81"	570mm/22.44"	570mm/22.44"
D	337mm/13.30"	330mm/13.00"	350mm/13.80"	456mm/18.00"	550mm/21.65"	550mm/21.65"
E	ø300mm/11.81"	ø300mm/11.81"	ø300mm/11.81"	ø396mm/15.60"	ø600mm/23.62"	ø600mm/23.62"
F	ø200mm/7.84"	ø200mm/7.84"	ø200mm/7.84"	ø265mm/11.40"	ø400mm/15.75"	ø400mm/15.75"
G	6 x ø10,5mm/0.41"	6 x ø10,5mm/0.41"	6 x ø10,5mm/0.41"	8 x ø10,5mm/0.41"	12 x ø13mm/0.51"	12 x ø13mm/0.51"
H	ø129mm/5.08"	ø129mm/5.08"	ø129mm/5.08"	ø345,6mm/13.60"	ø530mm/20.87"	ø530mm/20.87"
Max stern thickness	-	-	-	-	-	-

## Additional considerations for positioning of stern thruster.

- Make sure that the stern-tunnel does not disturb the waterflow under the hull
- Ensure that when installed the thruster does not foul existing equipment inside the boat like steerage links etc.
- It is essential that the motor is supported so that the total weight is not on the tunnel alone.
- Make sure that the water flow from the thruster are not interferred to much by sterndrives, trimtabs etc. as this will reduce the thrust considerably.
- It is possible to mount the tunnel off the boat's centre line if necessary.
- If the stern thickness is to much for the thruster in question you can easily remove material in the necessary area to fit the thruster. The stern thickness even here will never have to be less than the max. measurement given as max. stern thickness.

# BOLT ON INSTALLATION

2a. Once the place for the installation has been decided, hold the tunnel in place in the horizontal position and mark the bolt holes. Remove the tunnel and it is then possible to calculate and mark the centre (see Fig. 1).

3a. It is important that the tunnel flange sits flush on the transom. If this is not case, then the fitting area on the transom will have to be worked to ensure a snug fit.

PS ! Take care with grinders as it is very easy to remove to much fibreglass

At this time, cut out the centre hole and the transom to the same internal diameter as the tunnel flange and drill the bolt holes. Before actual fitting the stern tunnel, we recommend that the prepared area is sealed with a gelcoat or similar to ensure there is no water ingress.

4a. Before fitting the tunnel to the transom, install the gearleg to the tunnel as described in the thruster installation manual. For thrusters with external oil tank, we recommend that the oil feed pipe is fitted before the tunnel ist bolted to the transom.

5a. When fitting the tunnel, ensure that there is ample sealant (Sikaflex or similar) in the sealing tracks of the tunnel flange and around the bolts to make a water tight fitting (see FIG. 2&3).

Bolts, washers and nuts are not included as they will vary depending on the transom thickness. We recommend A4 stainless with A4 lock nuts and A4 washers of a large diameter on both outside and inside.

Bolts diameter (stainless steel):

ø 6mm or 1/4" for SE40/SE60

ø 10mm or 3/8" for SE60/SE80/SE100/SE120/SE130/SE150/SE170/SE210/SE285

SH100/SH160/SH240/SH300

ø 12mm or 1/2" for SH420/SH550

6a. The electromotor must have a solid support so that the weight can not cause a twisting action on the tunnel (see FIG. 4).

7a. Refer to the installation manual for the recommended thruster fitting.

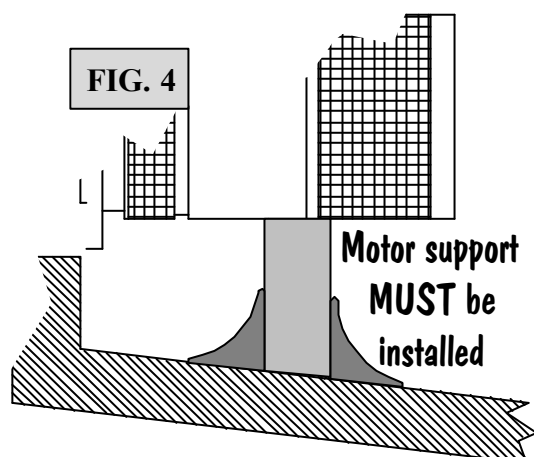
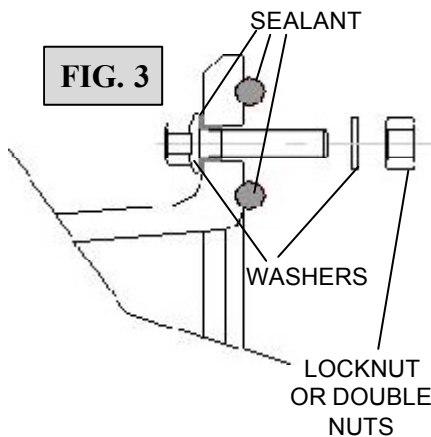
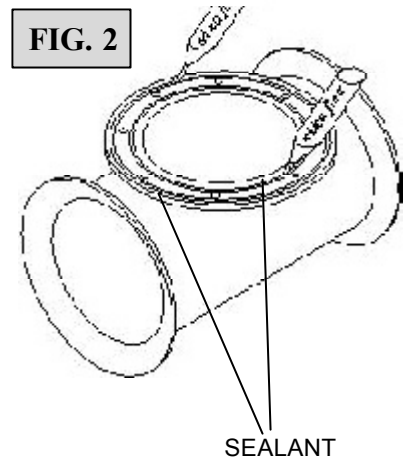

## MOULD IN INSTALLATION

### **WARNING!**

Mould in installation is **ONLY**  
for stern GRP tunnels.

Composite stern tunnels  
(Part # 90052i and 90086i )  
can not be moulded in this way.

- 2b. Cut of the bolting flange on the stern-tunnel
- 3b. Grind off the gelcoat both inside and outside the remaining “tube” atleast 10 cm down on the “tube” (see FIG. 5).
- 4b. Offer the stern tunnel to the desired position on the transom and mark around the tube.
- 5b. Cut the marked hole in the transom of the boat.
- 6b. Grind off the gelcoat on the transom of the boat in an area of atleast 10 cm / 4” around the hole, both outside and inside (see FIG. 5).

FIG. 5

**Grind off the bolt flange and the gelcoat both inside and outside in the areas shown.**

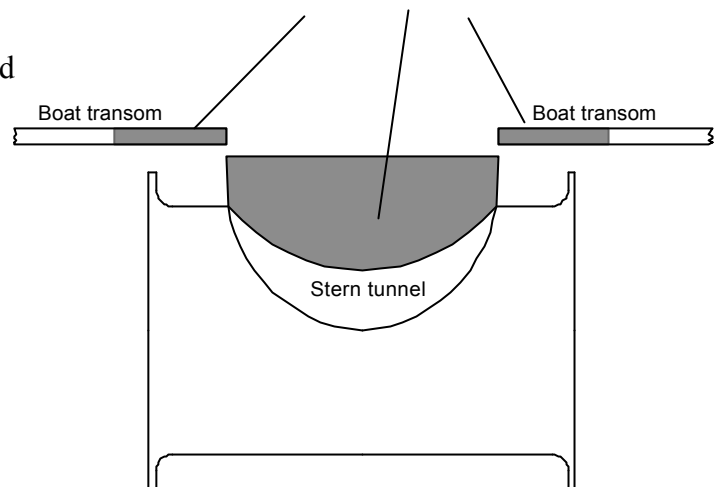

- 7b Offer the stern tunnel to the transom in the desired horizontal position, then bond to the transom with multi layers matt both inside and outside (see FIG. 6).

Take care not to reduce the internal diameter much, as this will make it more difficult to mount the thruster

- 8b Apply gelcoat or similar on all bonded areas.
- 9b Install the gear leg on the stern-tunnel as described in the installation manual for the thruster but fit the oil feed pipe first.

*Special installation points described on page 7 of this manual.*

FIG. 6

**Bond multiple layers both inside and outside**

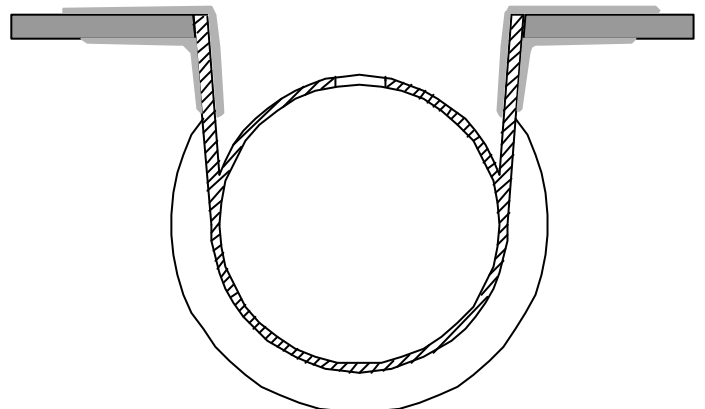

- 10b. The electromotor must be sturdily supported so that the weight-arm tension from the motor weight are not applied only on the tunnel (see FIG. 4)
- 11b. Basic installation of the flexible coupling, motor and electrical installation are described in the thruster manuals.

# THE STERN-THRUSTER MUST BE KEPT DRY AT ALL TIMES

*It is very important that you do everything possible to ensure that the thruster stays dry at all times.*

The electromotor and and solenoid system is not to be considered as waterproof, and will be damaged if they keep getting wet (rust and corrosion). Therefore, the thrusters installation compartment must be kept dry at all times.

This is more difficult for a sternthruster installation than for a bowthruster installation as the sternthruster has to be fitted in the bilge at the stern of the boat. This is generally a “wet” area that must be transformed into a dry area.

## *Important precautions !*

- You must seal all drain holes going into the compartment of the thruster.
- The surrounding compartments and any plates or compartments above must be drained in a good way to the bilge area in front of the thrusters installation compartment.
- If the propeller shaft or other moving parts with a high possibility for leakage comes through the bottom of the boat in the same compartment where the thruster is placed, you must make a seperate compartment for the thruster isolating it from these very normal and highly probable water leakages.
- The rudder shaft entrances to the boat and its surroundings must be drained so that any water coming in here are drained to go into the compartment in front of the sternthruster compartment.
- It is also important to ensure that the sternthrusters installation compartment will not be were water runs if a self-draining system of the boat deck fails to operate properly.
- Generally, all possible actions should be taken to ensure that water leakages from sources that are likely to have water leakages are drained to prevent water from entering the stern-thruster compartment.
- **We advice to install a self-activating bilge-pump, preferably with an alarm system, in the stern-thruster compartment. If you are not confident that you have been able to seal this comparnment well, this pump is absolutely necessary.**
- The control-cable system for the thruster must be installed so that atleast all junctions and connectors are kept dry at all times.
- In the Sidepower sternthruster kit, there will be included a cable, so that electronic controlbox originally placed on the electromotor, can be fitted away from the thruster in a higher position securing that it will stay dry at all times, even if there are accidental leakages into the stern-thruster compartment. Please see instructions on the following pages of how to connect this. If you are installing a sternthruster without the special sternthruster tunnel available from Sidepower, this kit can be bought seperately.

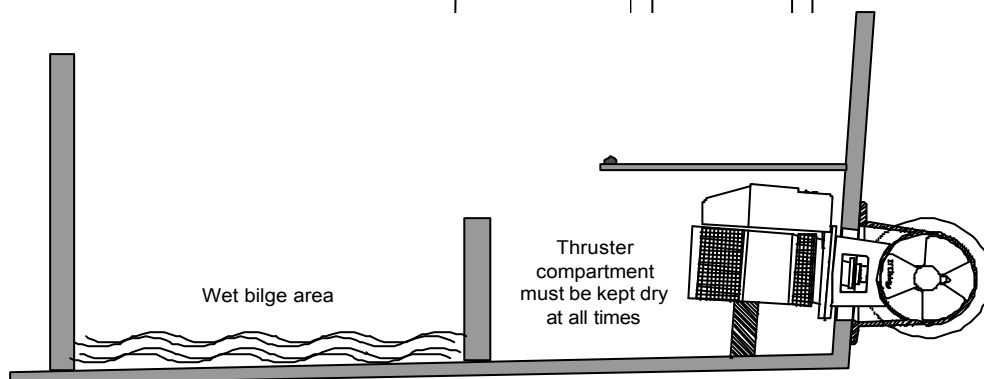
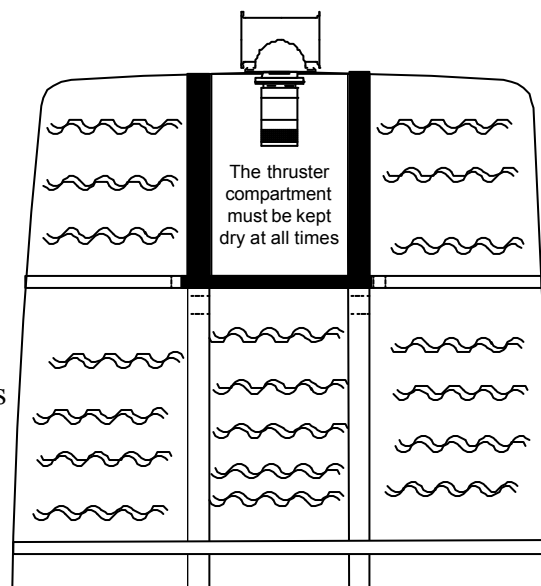

# THE STERN-THRUSTER MUST BE KEPT DRY AT ALL TIMES

*Description of illustrations:*

A : All draining holes or other openings from wet areas into the thruster installation compartment must be sealed.

B: Originally non-sealed bulkhead

C: Stringers in the boats length directions, normally there are drain holes through these from side-compartments

D: Plate above bilge where the steering system and other technical installations are often installed

E: Watertight bulkhead to engine room.

F: Thruster

G: Ensure there are draining holes in these positions to lead the water to the bilge to be pumpe out.

H Make anti drip edges on all surfaces above the thruster compartent to ensure that any water here will go via the drain holes and to the wet part of the bilge.

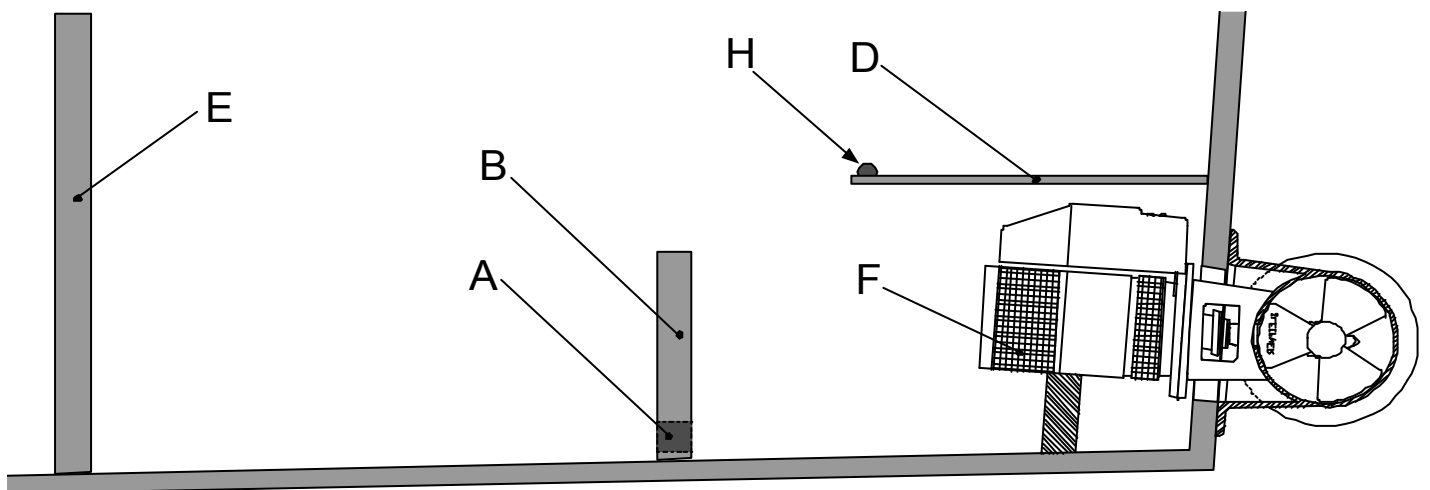
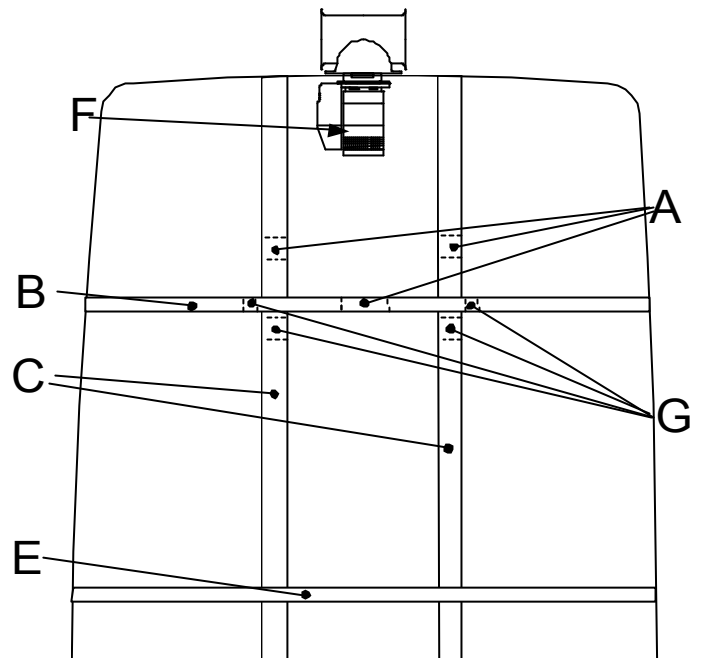
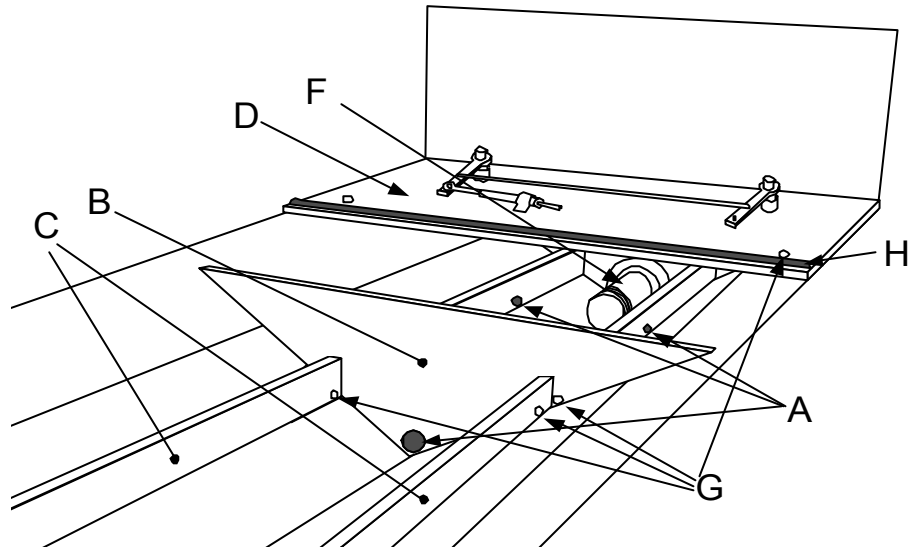

# SPECIAL INSTALLATION INSTRUCTIONS

## *Sidepower SP 55 Si*

As the motor/bracket are completely inside the stern-tunnel, the oil-pipe must be changed to an elbow connection so that the oil hose will not be bent, preventing from constrictions.

1. Remove the straight hose pipe in the bracket.
2. Install the elbow hose pipe connection that came with the stern-tunnel, be sure to use a sealant on the threads, but not so much that it closes the oil feed into the bracket.

## *Sidepower SP75Ti / SP95Ti / SP125Ti / SP100HYD*

As there are no room to place and fasten the lower part of the flexible coupling after the electric motor is fastened on the bracket, this must be done before fitting the motor.

PS! The part of the flexible coupling that is fastened on the motor, is prefixed in a specific position, on which this procedure is based. **DO NOT MOVE IT !**

1. When the gearhouse and bracket are mounted on the stern-tunnel, place the lower part of the coupling on the driveshaft.
2. Adjust the height of the lower part of the coupling to the measurement given in FIG. 8
3. Apply a thread glue (Loctite or similar) to the set screws and fasten the coupling by tightening both setscrews.

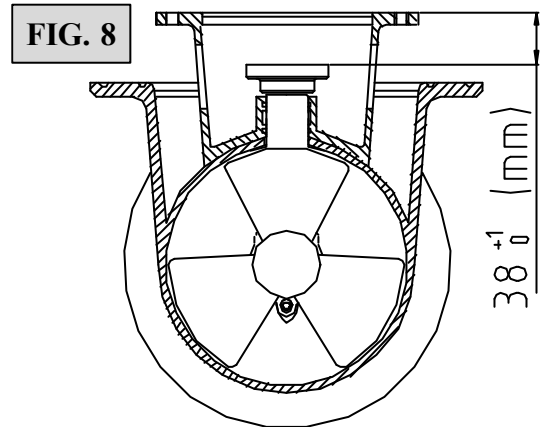

## *Sidepower SP155TCi / SP200TCi / SP240TCi / SP285TCi / SP220HYD / SP300HYD*

The lower part of the flexible coupling does not have to be tightened to the driveshaft. The fastening on the motor is sufficient. PS! Make sure the key on the shaft is in its correct position when sliding the motor with the flexible coupling onto it (see FIG. 9).

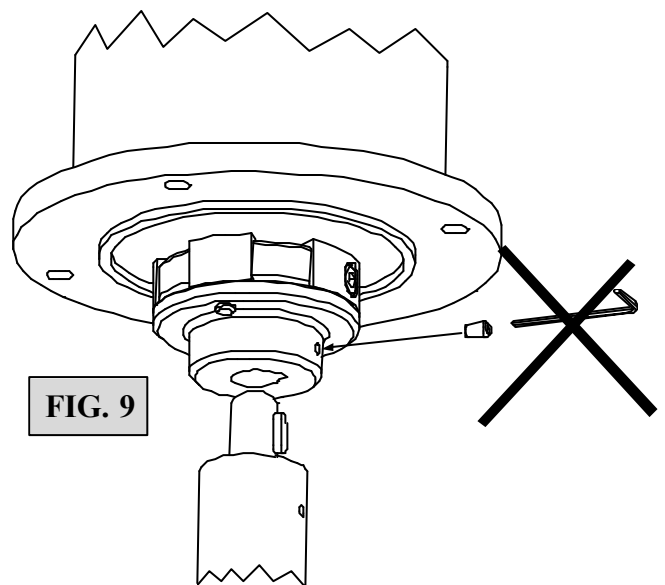



# REMOTE INSTALLATION OF THE ELECTRONIC BOX.

As the electronic controlbox and its contact are the most sensitive parts on the thruster, we advice that these are removed from the thruster and fitted in a high place in the boat so to secure these from water ingress, even if the thrusters compartment gets flooded.

Included with the stern-thruster tunnel kit is an extension cable that will allow you to do this.

Procedure:

- 1 Exchange the GREY and BLUE wires on the sides of the main solenoids that is coming from the electronic controlbox with the GREY and BLUE wires from the extension cable.
2. Exchange the BLACK, BROWN and WHITE wires from the electronic controlbox with BLACK, BROWN and WHITE wires in the extension cable.
3. Cut the strips holding the RED internal connections together with the other internal connections, and leave the RED wires on the main solenoids. Cut the red wire in accordance to drawing.
- 4 Remove the electronic controlbox and its harness from the solenoid system on the thruster.
- 5 Locate and fasten the electronic controlbox in a position where it will surely keep dry. This should be relatively high in the boat, so that even an extreme level of bilge water can not get to it. Also ensure that the position is safe against water running from above.
- 6 Remove the electronic controlbox from its original harness and plug it into the connector on the extension cable.
7. The extension cable to the control panel(s) must now be connecte to the AMP male plug on this remotely installed controlbox. Ensure that all controlcable junctions/connectors are placed so that they will stay dry at all times.

Electronic controlbox placed high, away from splashing water.

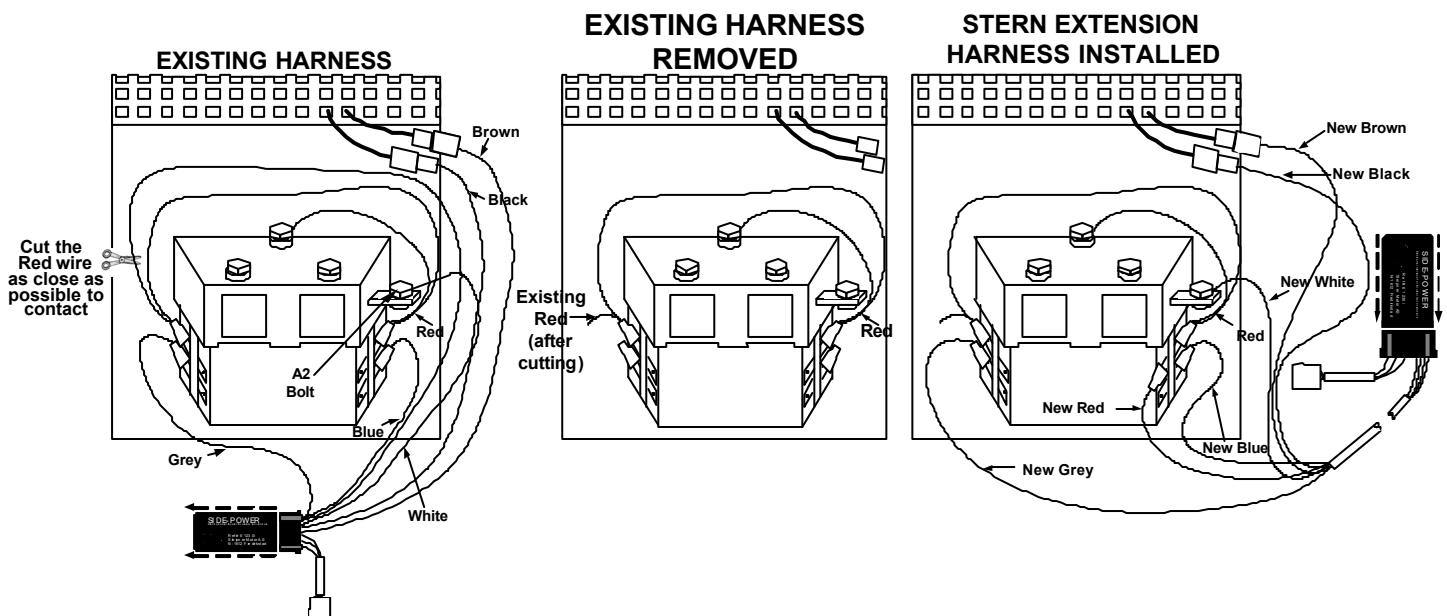
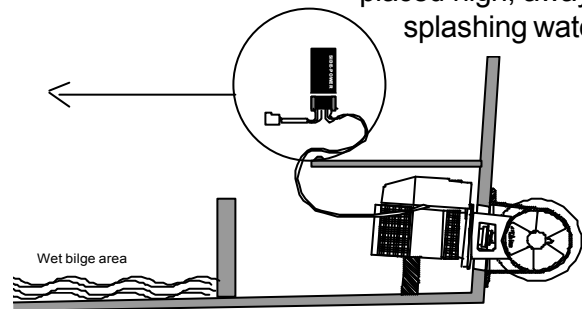
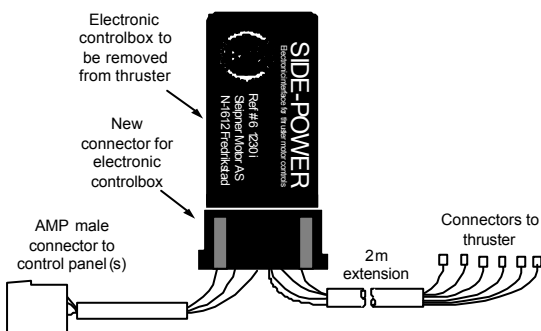



# ELECTRICAL INSTALLATION OF STERNTHRUSTER SYSTEMS

**PS ! This is additional information especially for sternthruster installations, and the installation manual for the thruster you are installing must be used complementary.**

If a bow thruster is also installed, we strongly advice to use seperate battery banks for the two thrusters to avoid extreme voltage drop if both thrusters were to be used at the same time, and to ensure maximum performance.

**Battery banks must have common minus!**

Refer to the thruster manuals for advised battery capacity and cable sizes for each thruster.

If a single control panel other than Sidepower's is to be used for both bow and stern thruster, be sure it has a single positive connection from only one of the two thrusters to avoid current leakage between the two battery banks. If you are installing the standard Sidepower dual joystick panel this is already taken care of.

## Wiring diagram for installation with original Sidepower dual joystick panel.

- When using the original Sidepower control cables just connect them to the corresponding joystick
- There are no plus/positive power connected from the sternthruster

### Visual connection diagram for dual joystick panel

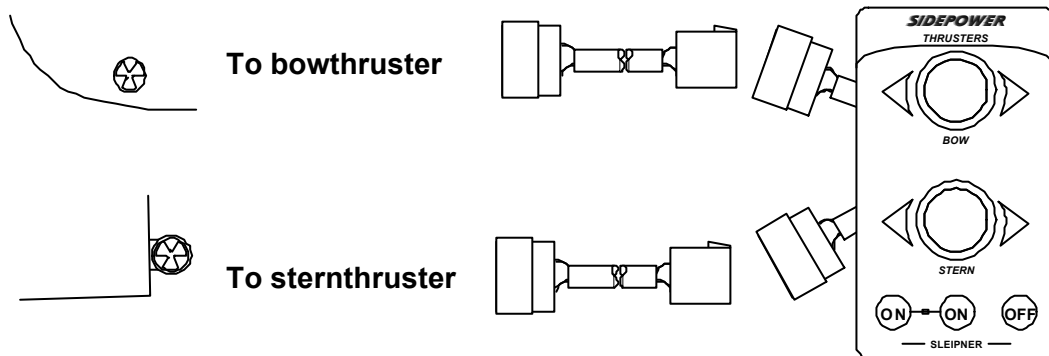

### Wiring diagram (simplified) for dual joystick panel

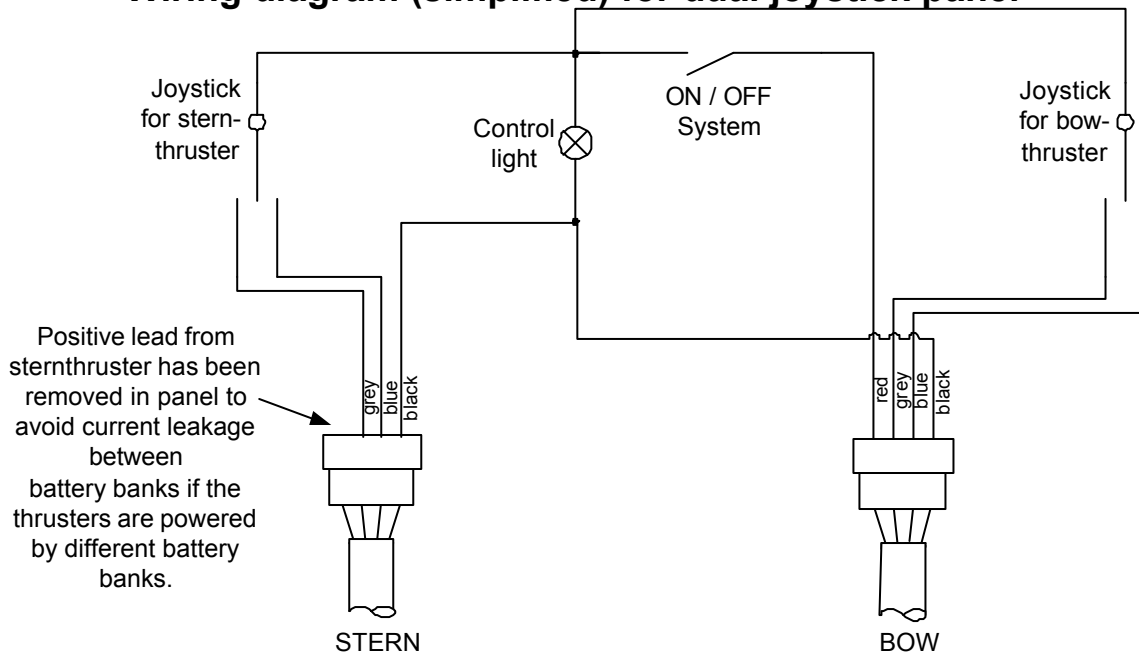

# ELECTRICAL INSTALLATION OF STERNTHRUSTER SYSTEMS

## To use the Sidepower dual joystick panel with previously installed Sidepower bowthruster with the older 3 lead electric system.

- Please contact your distributor / dealer to purchase an upgrade kit to rebuild your existing bowthruster to the new 4 lead electric system. The wiring diagram on the previous page will then be the correct one for your complete system.

## To use the Sidepower dual joystick panel with previously installed thruster of other brand.

- You should not use the Sidepower dual joystick panel as it is not designed to run other thruster brands. It may be possible but you must consult a skilled electrician to ensure the compatibility. The panel can supply a maximum of 1Amp. in the standard configuration and will therefore normally not be able to directly drive main solenoids on a thruster.
- If you wish to use this panel to control another brand of bowthruster, a possible solution is to rebuild the dual joystick panel, so that it for all practical purposes is transformed into two different controls. This is done by removing all connections on the “bow-joystick” including the Sidepower connector and the yellow cables between the two joysticks. You must then connect the black lead coming out of the ON/OFF system in the panel to a separate ground/negative with the same ground potential the thruster because there are no ground coming from the sternthruster. By this, the “bow-joystick” is totally separated from the Sidepower panel and can be used and connected as any other joystick or two way switch. Consult your other brand thruster manual for correct connections. We advice to always fit an ON/OFF switch on the input lead to the joystick so that it’s function can be de-activated when the thruster is not in use. See example diagram below.

### Visual connection diagram for rebuilt dual joystick panel

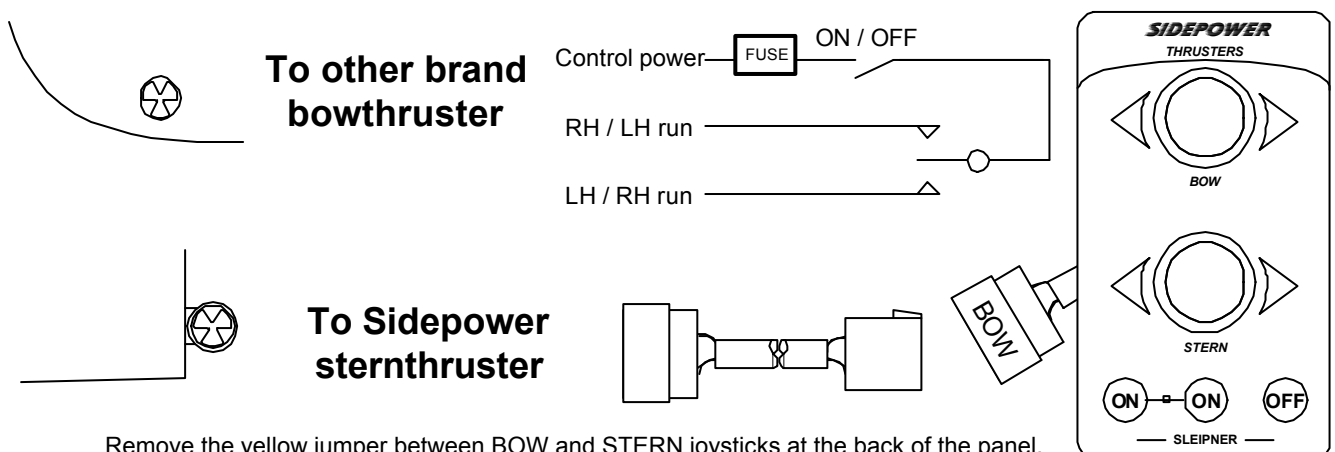

Remove the yellow jumper between BOW and STERN joysticks at the back of the panel.  
Move the two grey leads from the BOW joystick to the STERN joystick (a total of four grey leads at STERN joystick)  
Move the two blue leads from the BOW joystick to the STERN joystick (a total of four blue leads at STERN joystick)  
Contact marked with STERN is NOT in use!

**NB!** *Sleipner Motor claims no compatibility with other thruster brands and assumes no responsibility for connection or usage with other thruster brands.*

# INSTALLATION CHECKLIST

- There is a sturdy additional support under the electric motor, taking the weight/ load of the electromotor away from the stern-tunnel.
- All bolts are securely tightened and sealant is applied as instructed
- All necessary actions have been taken to ensure that the thrusters installation compartment will stay dry at all times.
- The electronic controlbox of the thruster have been remotely fitted in a high place where there are no chance it will be submerged or splashed with water.
- All electrical wiring, cable sizes and battery capacity is according to the thruster installation manual.
- The unit has been moved by hand and found to run freely.
- The gear house, oil-hose and oiltank are filled with oil
- The gearoil tank is installed a minimum of 200mm above the waterline.

## IMPORTANT USER ADVICE

- Never use the thruster if there are people or animals swimming in the area around the thruster. The thruster propeller can cause serious injuries when it is running.
- **WARNING !** Never store any items that can leak explosive gas in the same room where the sternthruster is fitted. The thruster will create sparks that can cause an explosion if there are explosive gases present.
- When the boat is going backwards in a “dirty” harbour with lots of floating objects / debris, this can be “collected” by the transom of the boat. These objects / debris can cause damage to the thruster if sucked into the tunnel while the thruster are being operated. All the thrusters are built with safety devices (shearpin in the SE 30 / SE 40 / SE 60 & flexible couplings in the SE 80 / SE 100 / SH 100 / SE 120 / SE 170 / SE 210 / SH 240 / SP240TCi / SP285TCi / SP300HYD / SH 420 / SH 550 models) changeable from inside the boat, but damages can occur to other parts of the thruster in certain cases.
- Always turn of the main power / disconnect the thruster from the batteries before touching any moving parts of the thruster inside or outside the boat.
- If the thruster does not move the boat/does not give any thrust you must immediately stop trying to run it and turn off the main power switch until the reason for this is found and corrected.
- This manual is in addition to the general thruster manual, so this must be read and understood also !

### **IMPORTANT NOTICE**

*Sleipner Motor AS assumes no responsibility or liability for the installation of any components. Skilled installers should be used, and there might be unforeseen factors that can make one or more installation instructions wrong or not entirely correct for the boat in question. The installation responsibility is thereby solely on the party that are actually performing the installation.*

STERNTHRUSTER TUNNEL INSTALLED BY: .....

DATE:.....

INSTALLED THRUSTER: .....

### Argentina

Trimer SA  
Buenos Aires  
Tel: +54 11 4580 0444  
Fax: +54 11 4580 0440  
www.trimer.com.ar  
trimer@trimer.com.ar

### Australia

AMI Sales  
Freemantle, WA  
Tel: +61 89 331 0000  
Fax: +61 89 314 2929  
ami@amisales.com.au

### Austria

G. Ascherl GmbH  
Hard, Bregenz  
Tel: +43 5574 899000  
Fax: +43 5574 89900-10  
www.ascherl.at  
office@ascherl.at

### Benelux

ASA Boot Electro  
Watergang  
Tel: +31 20 436 9100  
Fax: +31 20 436 9109  
www.asabootelectro.nl  
info@asabootelectro.nl

### Brazil

Electra Service Ltda.  
Guaruja  
Tel: +55 13 3354 3599  
Fax: +55 13 3354 3471  
www.electraservice.br.com  
albertoni@electraservice.com.br

### Bulgaria

Yachting BG  
Burgas  
tel: +359 56 919090  
fax: +359 56 919091  
www.yachting.bg  
info@yachting.bg

### Canada

Imtra Corporation  
New Bedford, MA  
Tel: +1 508 995 7000  
Fax: +1 508 998 5359  
www.imtra.com  
side-power@imtra.com

### China/Hong Kong

Storm Force Marine Ltd.  
Wanchai, Hong Kong  
Tel: +852 2866 0114  
Fax: +852 2866 9260  
www.stormforcemarine.com  
sales@stormforcemarine.com

### Croatia

Yacht Supplier  
Icici  
Tel: +385 51 704 500  
Fax: +385 51 704 600  
acyachting@gmail.com

### Cyprus

Ocean Marine Equipment Ltd  
Limassol  
Tel: +357 253 69731  
Fax: +357 253 52976  
oceanm@spidernet.com.cy

### Denmark

Gertsen & Olufsen AS  
Hørsholm  
Tel: +45 4576 3600  
Fax: +45 4576 1772  
www.gertsen-olufsen.dk  
info@gertsen-olufsen.dk

### Estonia/Latvia/Lithuania

Miltec Systems OÜ  
Tallin  
Tel: +372 5013997  
Fax: +372 6442211  
www.miltec.ee  
tony@miltec.ee

### Finland

Nautikulma OY  
Turku  
Tel: +358 2 2503 444  
Fax: +358 2 2518 470  
www.nautikulma.fi  
nautikulma@nautikulma.fi

### France

Kent Marine Equipment  
Nantes  
Tel: +33 240 921 584  
Fax: +33 240 921 316  
www.kent-marine.com  
contact@kent-marine.com

### Germany

Jabsco GmbH  
Norderstedt  
Tel: +49 40 535 373-0  
Fax: +49 40 535 373-11

### Greece

Amaltheia Marine  
Athens  
Tel: +30 210 2588 985  
Fax: +30 210 2588 986  
www.amaltheiamarine.com  
amalmar@otenet.gr

### Iceland

Maras EHF  
Reykjavik  
Tel: +354 555 6444  
Fax: +354 565 7230  
www.maras.is  
gummi@maras.is

### India

Indo Marine Engineering Co. Pvt. Ltd  
Pune, Maharashtra  
Tel: +91 20 2712 3003  
Fax: +91 20 2712 2295  
siddharth@indogroup-asia.com

### Ireland

Sleipner Motor Ltd.  
South Brent  
Tel: +44 1364 649 400  
Fax: +44 1364 649 399  
andy@sleipner.co.uk

### Israel

Atlantis Marine Ltd.  
Tel Aviv  
Tel: +972 3 522 7978  
Fax: +972 3 523 5150  
www.atlantis-marine.com  
atlantis@inter.net.il

### Italy

Saim S.P.A.  
Assago-Milan  
Tel: +39 02 488 531  
Fax: +39 02 488 254 5  
www.saim-group.com

### Japan

Turtle Marine Inc.  
Nagasaki  
Tel: +81 95 840 7977  
Fax: +81 95 840 7978  
www.turtle-marine.com  
info@turtle-marine.com

### Malta

S & D Yachts Ltd.  
Cali  
Tel: +356 21 339 908  
Fax: +356 21 332 259  
www.sdyachts.com  
info@sdyachts.com

### New Zealand

Advance Trident Ltd.  
Auckland  
Tel: +64 9 845 5347  
Fax: +64 9 415 5348  
www.advancetrident.com  
service@advancetrident.com

### Norway

Sleipner Motor AS  
Fredrikstad  
Tel: +47 69 30 00 60  
Fax: +47 69 30 00 70  
www.side-power.com  
sidepower@sleipner.no

### Poland

Taurus Sea Power SP. Z.O.O  
Gdansk  
Tel: +48 58 344 30 50  
Fax: +48 58 341 67 62

### Portugal

Krautli Portugal Lda.  
Lisboa  
Tel: +351 21 953 56 00  
Fax: +351 21 953 56 01  
www.krautli.com  
contact@krautli.pt

### Russia

Standarte  
Starbeyevo  
Tel: +7 495 575 67 23  
Fax: +7 495 575 39 77  
www.standarte.ru  
info@standarte.ru

### South Africa

C-Dynamics  
Cape Town  
Tel: +27 21 555 3232  
Fax: +27 21 555 3230  
www.c-dynamics.co.za  
info@c-dynamics.co.za

### Spain

Imnasa Marine Products  
Girona  
Tel: +34 902 300214  
Fax: +34 902 300215  
www.imnasa.com  
imnasa@imnasa.com

### Sweden

Sleipner AB  
Strömstad  
Tel: +46 526 629 50  
Fax: +46 526 152 95  
www.sleipnerab.se

### Switzerland

Marine Parts Technics AG  
Volketswil  
Tel: +41 1 997 40 90  
Fax: +41 1 997 40 94  
www.marineparts.ch  
info@marineparts.ch

### Singapore/Malaysia/ Indonesia/Vietnam/Phillippines

Island Marine Services Pte Ltd  
Singapore  
Tel: +65 6795 2250  
Fax: +65 6795 2250  
www.island-marine.com  
karl@island-marine.com

### Taiwan

Mercury Marine Supply  
Kaohsiung  
Tel: +886 7 3317 293  
Fax: +886 7 3314 232

### Turkey

Denpar Ltd.  
Istanbul  
Tel: +90 212 346 1332  
Fax: +90 212 346 1329  
seda@denpar.com

### UK

Sleipner Motor Ltd.  
South Brent  
Tel: +44 1364 649 400  
Fax: +44 1364 649 399  
andy@sleipner.co.uk

### United Arab Emirates

Teignbridge Propellers & Marine  
Equipment Co. Ltd.  
Dubai  
Tel: +971 4 324 0084  
Fax: +971 4 324 0153  
teignpro@emirates.net.ae

### USA

Imtra Corporation  
New Bedford, MA  
Tel: +1 508 995 7000  
Fax: +1 508 998 5359  
www.imtra.com  
side-power@imtra.com

