

IMPORTANT!

Fitting the fuse into the fuseholder

To avoid heating and voltage drop, it is very important that the fuse/fuseholder is assembled exactly as shown here with the fuse between the contact plates.

- A. Holder with bolts
- B. Tin plated copper contact plates
- C. Washer
- D. Spring washer

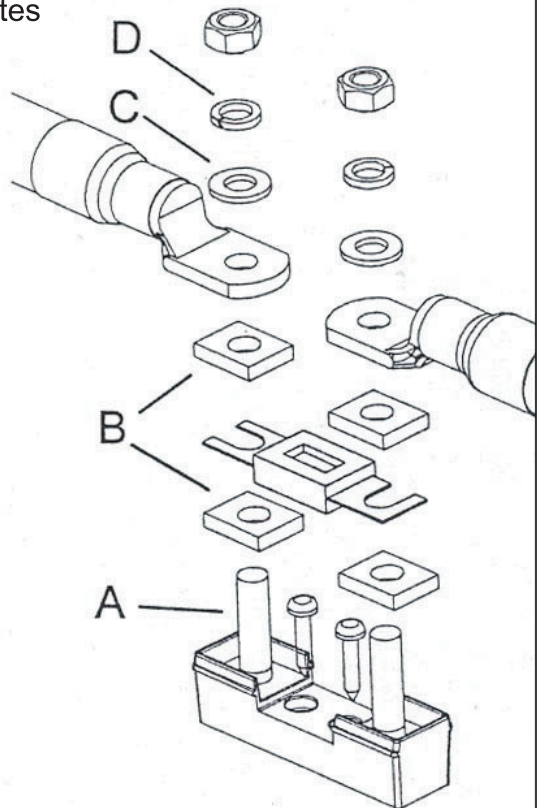

If using double cables,
fit them "back to back"
- as shown here:

