

SIDE-POWER  
Thruster Systems

# Boatbuilder installation recommendation

## Where and how to fit a thruster tunnel

This recommendation will go through the different factors to consider when choosing where and how to fit thruster tunnels in a boat.

Some of these recommendations might be difficult, or even impossible to follow exactly in some boats, and they are general recommendations, not requirements.

However, we strongly advice that you consider these recommendations when planning installations of thrusters, as these factors makes a big difference on the thrusters performance as you will also be able to remove about all negative effects a thruster tunnel installation can have on a boat.

## Planning and general precautions for thruster installations.

- ✍ The thruster must NOT be installed in compartments that require ignition proof electric equipment. If necessary, make a separate compartment.
- ✍ If you are installing the Sidepower in a small room /compartment, it should be ventilated to ensure cooling of the electromotor.
- ✍ If the height in the room you are installing the Sidepower is limited, the Sidepower can be installed horizontally or at any angle in between.
- ✍ If the electro motor is positioned more than 30° off vertical, it must be supported separately.
- ✍ If the electromotor is installed in a horizontal position, the connector of the electronic controlbox on the solenoids has to face downwards.
- ✍ Beware to keep installation within advised measurements. No part of the propeller or gearhouse must be outside the tunnel.
- ✍ The electromotor, its components, contacts / plugs or other joints in the control cables must be mounted so that they will keep dry at all times.
- ✍ We strongly advice to paint the gearhouse and propellers with antifouling.  
PS! Do not paint the zinc anodes, sealings or propellershafts.
- ✍ Don't install the electromotor at close range to easily flammable objects as it will reach over 100°C before the temp. switch is activated.
- ✍ When installed in boats approved or classified according to international or special national rules, the installer is responsible for following the demands in accordance with these regulations / classification rules. The instructions in this guide can not be guaranteed to comply with all different regulations / classification rules.
- ✍ Remember that the GRP tunnel is very accurately manufactured and that the propellers have a maximum diameter to get the maximum thrust. Thereby you can NOT finish the inside of the tunnel with a layer of Gelcoat / Topcoat or similar. It is only room for a thin layer of primer and two layers of anti-fouling.
- ✍ It is important to plan the thruster installations as early in the design process of the boat as possible.

## Thruster positioning

The positioning of the thruster as well as the tunnel end shape will have a substantial impact on the actual effect the thruster has on the boat.

Basically, the thruster should be placed as deep and as far forward as possible in the hull to obtain maximum thruster performance in a boat.

However, there are several other factors to consider also as you want the tunnel installation to create as little drag for the boats forward movement as possible, as little noise as possible and as little spray when driving at high speed as possible.

Thereby, the tunnel installation is individual for each boat and should be chosen considering all the different factors presented here, as well as any particular factor that special for the boat you are working on.

### The thruster should be as far forward as possible.

Because of the leverage effect around the boats pivot point, it is very important for the thrusters actual effect in the boat to get it as far forward as possible.

The relative distance change from the boats pivot point to thruster installation point will be the change of actual thrust for the boat.

*Example* : A: 75kg thrust x 11m leverage = 825kgm thrust force on the boat.

B: 85kg thrust x 10m leverage = 750kgm thrust force on the boat.

As this example shows you get 10% more actual thrust to turn the boat around in position A.

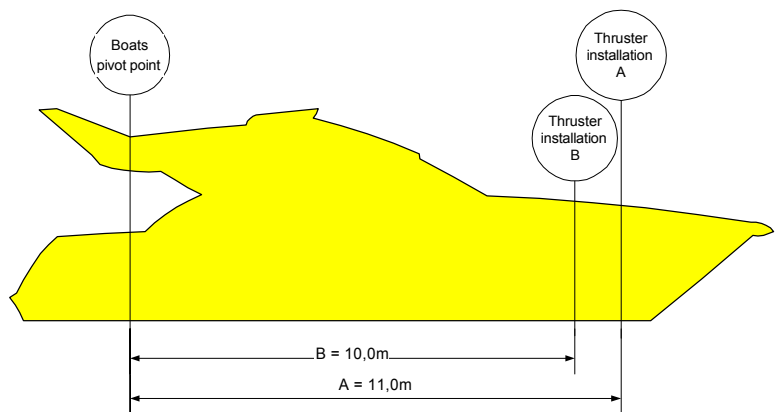

### The thruster should be placed as deep as possible.

The thruster tunnel should be placed as deep as possible for two reasons:

1. So that it does not suck down air from the surface, which will totally destroy thrust and make a lot of noise.
2. To get as high as possible water pressure so that the propeller has as firm a substance as possible to work in for the best possible performance.

Generally the top of the tunnel should be an absolute minimum of 1/2 x the tunnel diameter below the water surface. We recommend that it is at least 3/4 x tunnel diameter below the surface and even more is better.

It is also important to remember that on small boats with small thrusters these measurements can then be as little as 75-80mm below the waterline and if it is a very lightweight boat you can often get waves moving the boat up and down more than this creating problems of sucking air into the tunnel.

If you get top of the tunnel 30-35cm / 1' below the surface, other factors will normally be more important as the water weight/pressure increase more slowly from that depth and on.

## Optimal tunnel length.

If the tunnel gets too long, the friction inside will reduce the water speed and thereby the thrust.

If the tunnel gets too short (normally only in the bottom section of the tunnel) you can get cavitation problems as the water will not have had time to “straighten” itself before reaching the propeller. This cavitation will reduce performance as well as creating a lot of noise.

The optimal tunnel length is 2 to 4 x tunnel diameter and you should avoid tunnels longer than 6 to 7 times the tunnel diameter as the performance reduction is then clearly noticeable.

## Other limitations.

Leave at least 1/3 of the tunnel diameter of hull below and in front of the tunnel so that water does not go out on one side and then in on the other side. However, this is not as important if the tunnel is not very short in the bottom area.

The internal layout will for many be the most difficult physical limitation for a perfect thruster positioning. But, please remember that a Sidepower thruster can be fitted in any angle on the tunnel.

If your selected installation point means cutting a chine / stiffener in the hull, this will normally not be a problem. The installation of a tunnel will strengthen and stiffen any bow, so you can safely cut a chine or part of the stiffener and still have getting a stronger and stiffer bow than without the thruster tunnel.

(The round shape of the tunnel makes it exceptionally strong and rigid)

## Tunnel out of the water at high speed.

In high speed boats, it is always an advantage to get the tunnel out of the water at high speed.

However, it is not a very important point, as the tunnel installation can be made so that it creates virtually no drag at all and protects the thruster from being driven by the water pushing through the tunnel at high speed.

However, we always recommend to fit the tunnel so that it is out of the water at high speed, providing necessary depth for the tunnel is provided at “thruster speed”.

## Example:

This example shows where we would fit the tunnel in a boat with this bow shape.

The reasons for choosing to install it at a depth between 3/4 & 1/1 x tunnel diameter, is that in this case it will get the tunnel above the waterline at high speed, while still having it almost as far forward as possible and at a reasonable depth.

If it was not a factor to get it above the high speed waterline, we would give priority to get it to the full 1/1 x tunnel diameter, as it would only sacrifice the length forward by 0,5 x tunnel diameter and thereby give at least the same thrust, and normally lower the noise some.

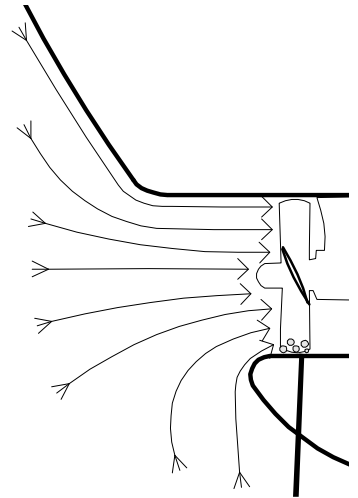
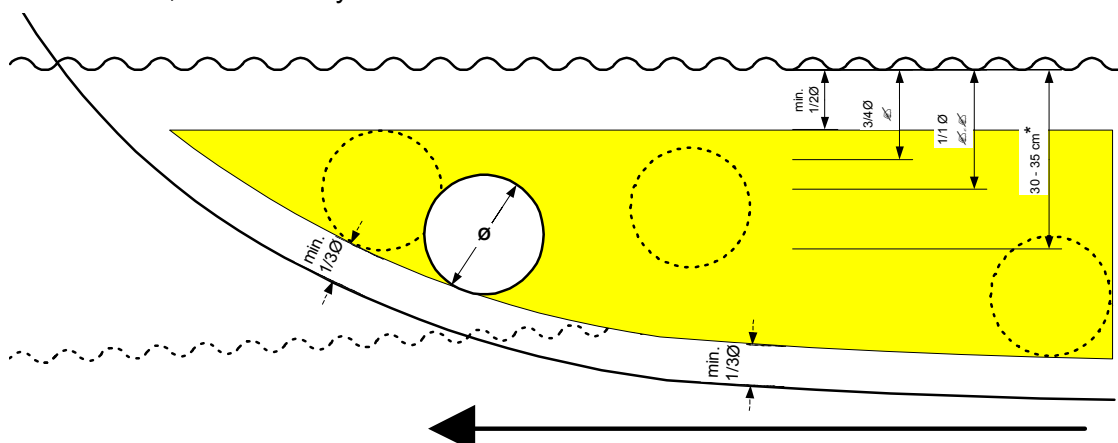

## Rounded tunnel ends will maximize thrust and minimize noise.

We recommend to round the tunnel connection to the hull-side as much as possible. The optimum rounding is a radius of 10% of the tunnels diameter.

This will give these advantages over sharp tunnel to hull connections.

1. The curved tunnel will prevent creation of turbulence / cavitation that will come from a sharp tunnel end when water passes fast, thereby preventing a double negative impact on the thrust and noise level..
  - The turbulence / cavitation blocks the outer area of the tunnel and thereby actually reduces the effective tunnel diameter and thrust.
  - The turbulence / cavitation hits the propeller and thereby reduces the propellers performance and creates noise.
2. The curved tunnel end makes the thruster take water also from along the hull-side, creating a vacuum that will suck the boat sideways and thereby give additional thrust. With a sharp tunnel end, the thruster will be unable to take water from along the hull-side, and you will not get the desired vacuum and additional thrust.

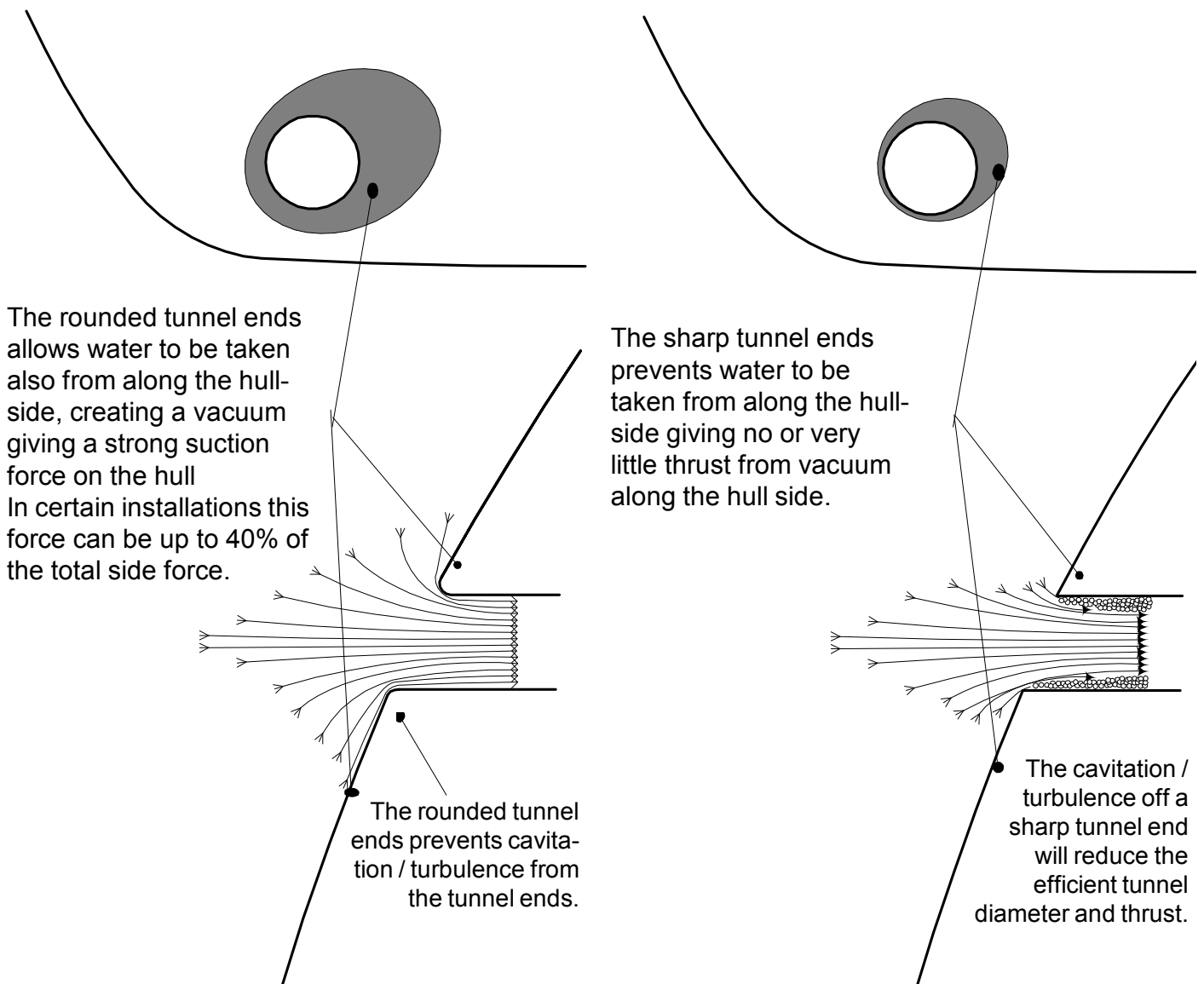

## How to make the rounded tunnel ends.

If you are installing a thruster in a hull that has not been specially prepared for this in the mould, you will have to make the inside bonding of the tunnel to the hull extra thick so that you can grind off more outside to make the rounding / slope before you do the outside bonding layers.

An angled slope between the tunnel and the hull-side is a good alternative that might be easier to do.

*If you are unable to make the full radius of 10% of the tunnel diameter, you should still make as much of a curve or slope as your installation allows.*

*All curving / angling of the tunnel ends towards the hull-side are better than a sharp edge.*

For boatbuilders having thrusters as standard, please see page 7.

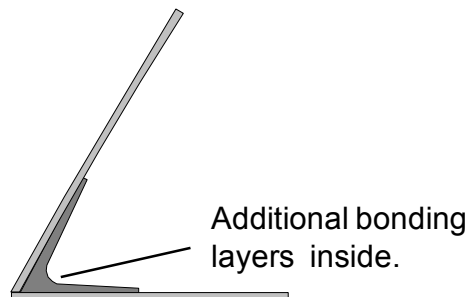
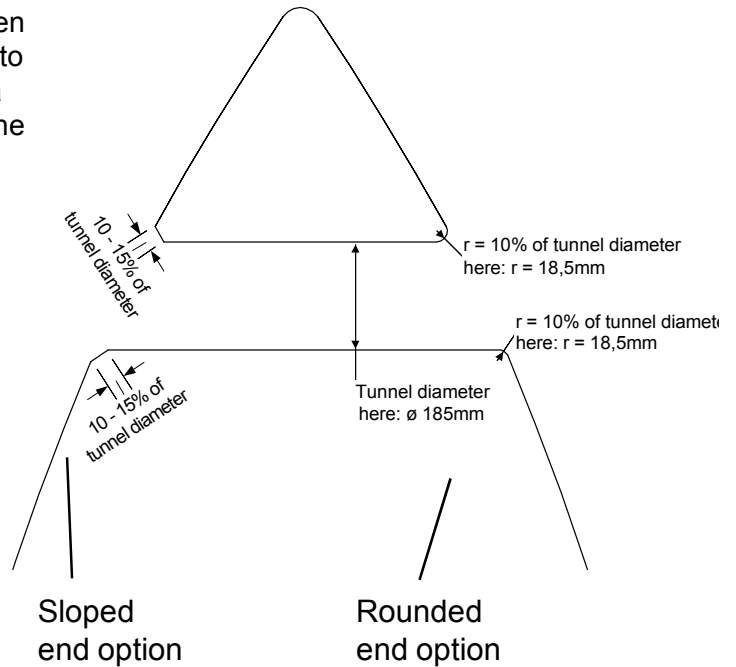

Grind to make the desired slope, remember to also grind the bonding area around the tunnel for outside layers to be flush with the hull and inside of the tunnel

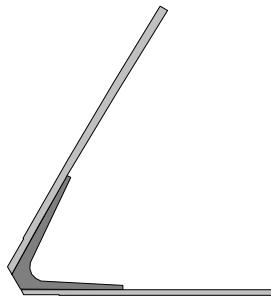

Grind to make the desired radius, remember to also grind the bonding area around tunnel for outside layers to be flush with the hull and the inside of the tunnel



Make outside bonding layers



Make outside bonding layers

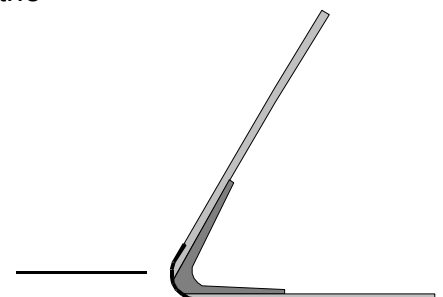

## How to prevent drag from the tunnel.

A possible problem in sailboats or fast powerboats, is that they get a drag from the back face of the tunnel, as this becomes a “flat” area facing the water flow

This can be solved two different ways, depending on what is possible or more easy to do.

1. The best solution which normally reduces the drag most, is to make an insert in the hull at the back of the tunnel. Thereby the back face is gone, and thereby about all the drag.

The depth and shape of this insert will be depending on the boat. Basically you should not see the back face of the tunnel when standing directly in front of the tunnel at the angle of the boats centreline.

The angle up or down backwards of the insert in the hull, depends on the hullshape, but normally it is angled slightly down because of the waterflow on this area of the hull.

However, for fast planning boats it can be that it should be angled upwards as many boats will be travelling at speed with a raised bow, and the boat will be going up and down in the waves. Again, consider the flow of water when the boat is at it's normal speed and make the insert so that the water flow will not hit the backface of the tunnel.

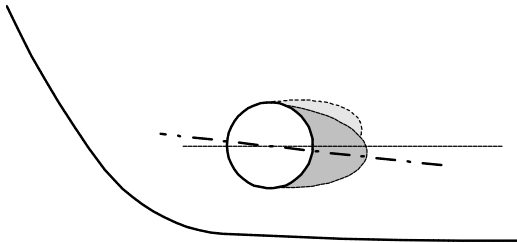

2. The drag will also be reduced a lot, especially in fast power boats, by making a deflector / spoiler in front of the tunnel.

This will push the waterflow out from the hull so that most of it passes outside the back face of the tunnel.

The shape and size of this deflector will be depending on the hull shape. Basically you should not see the back face of the tunnel when standing directly in front of the tunnel at the angle of the boats centreline.

The easiest way of making this is to let a part of the tunnel stick out in the lower forward area of the hole, and use this as a support to mould a soft curve / spoiler shape

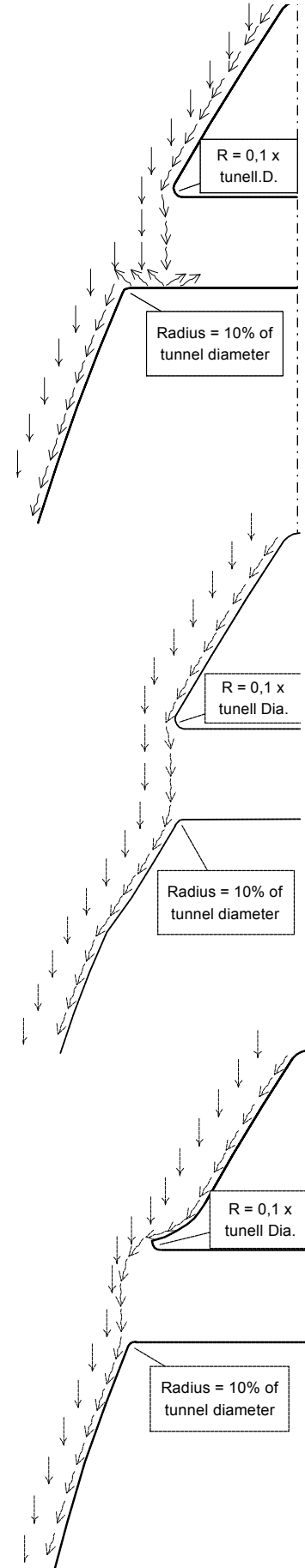
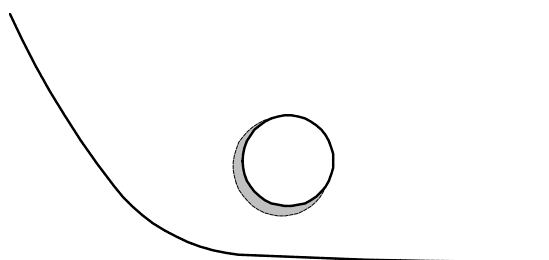

## Installation in sailboats with shallow and “flat” bows.

Many sailboats have a racing type hull which means that it is very flat bottomed and has a very shallow draft in the bow section. It is thereby very difficult not to say impossible to fit a tunnel thruster.

One option for these sailboats when the owner wants the great advantages of a thruster is to fit a retractable thruster, however, these also has a lot of disadvantage as: very expensive, takes up a lot of room (height) inside the boat, risky reliability with lots of moving parts etc.

However, it will be possible to install a tunnel thruster in most sailboats, even when the hull does not directly support the fitting of a tunnel.

This is done by fitting the tunnel halfway into and halfway underneath the existing hull and then strengthen it and smoothening the waterflow by moulding a bulb around / underneath the tunnel.

This will allow installation in good position on the boat, maintaining the reliability and space advantages of a tunnel thruster.

This installation are being used by some of the worlds absolute largest sailboat builders, and have been proven to give little to no speed loss for normal sailers.

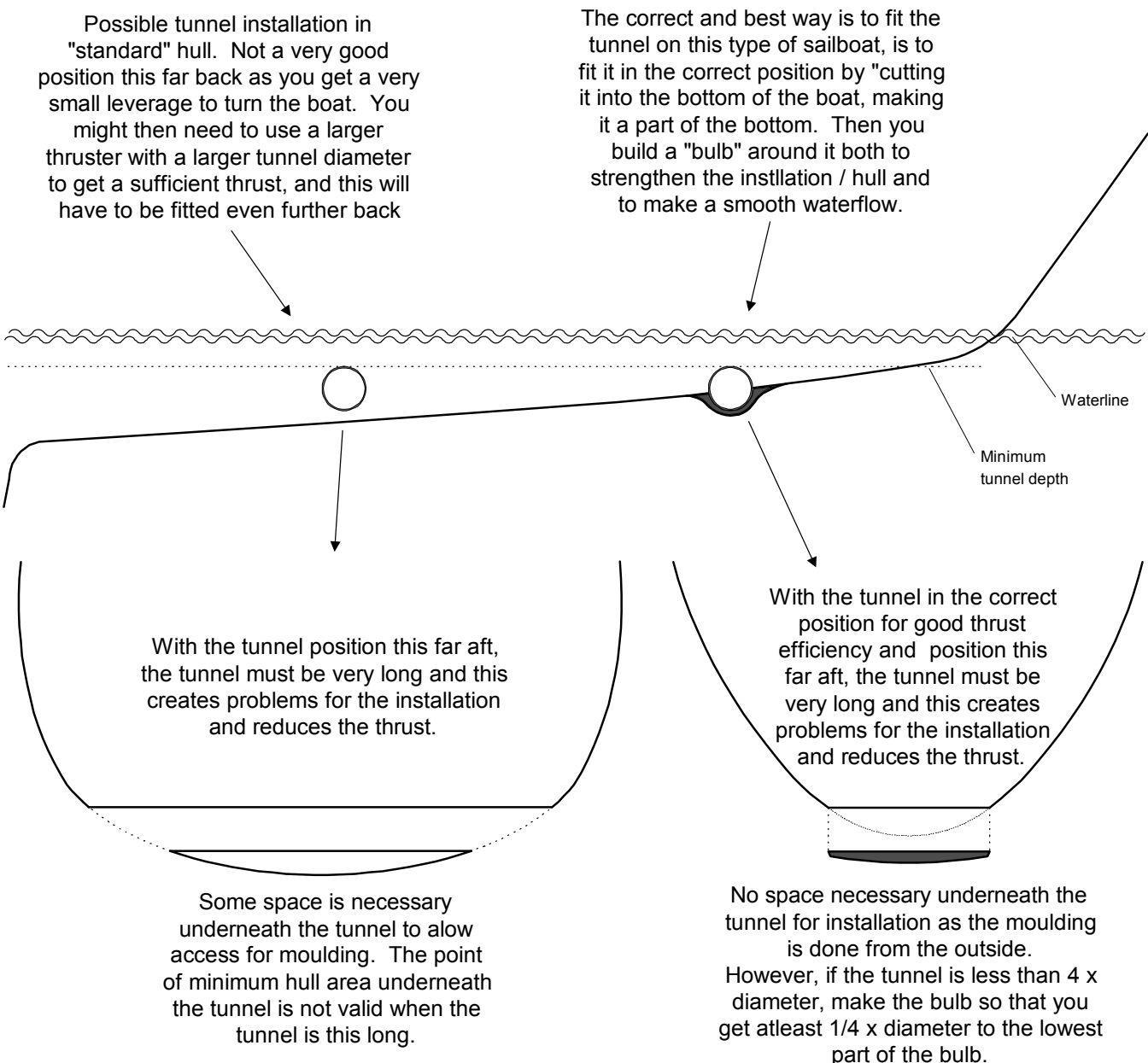



## How to easily make a perfect installation in a boat where a thruster is standard equipment.

Boat builders having thrusters as standard, or delivers a large portion of one or more models with thrusters, have the opportunity to make a perfect tunnel installation, while saving both time and money on each installation.

The solution is to make an insert / plug in the hull mould, which prepares the hull for an easy tunnel installation and creates the rounded tunnel ends for maximum thrust and minimal drag.

This insert / plug in the mould are not very difficult to make, and as it will have to be a "bolt on" in the mould in order to get the boat out, you can still make boats without this hull feature. ( Some builders have this in the hull also on boats that are delivered without a thruster as they know many people will fit this later)

By having a flat surface to fit the tunnel to, the installation time and cost for the tunnel will also be reduced as:

- it is very easy and fast to cut the now circular hole for the tunnel
- it is easier to mould inside all around the tunnel
- you save tunnel length

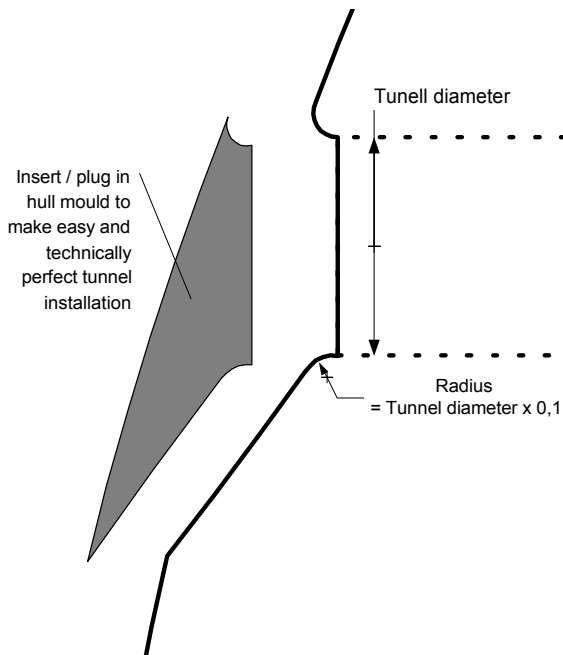
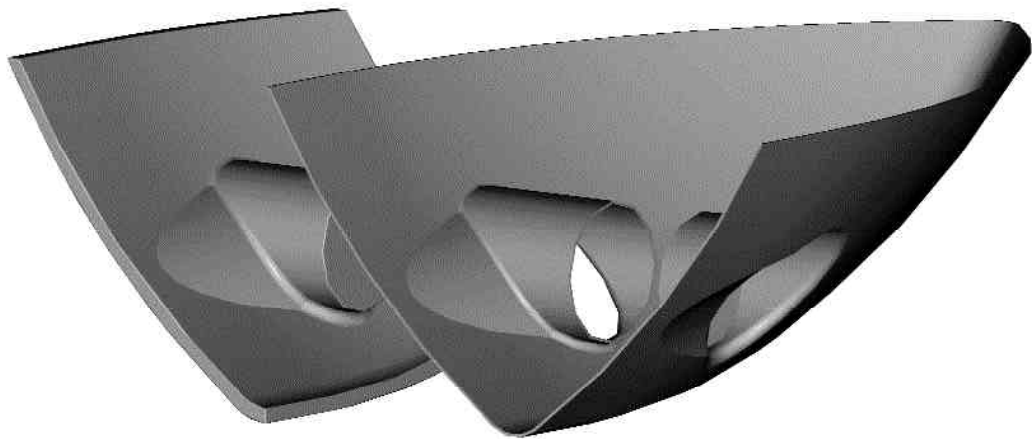

**Sketch of the plug that can be fitted in the hull mould.**

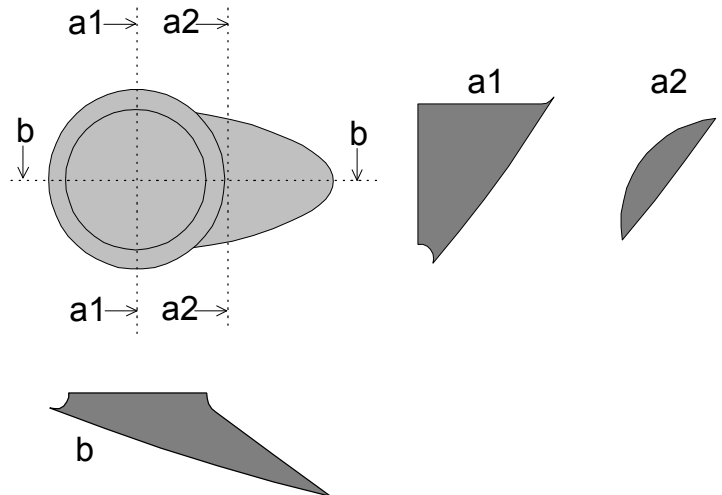

## Simple alternative for preventing drag from the tunnel installation.

If you would prefer not to have a plug in the mould that has to be bolted in so that it can come out of the boat mould with the boat you can make a plug that a fixed part of the boats mould.

You will have to ensure that there is a enough release angle to lift the boat out, and it could be that you are unable to make the perfect insert for the water flow. As this does not create the rounded tunnel ends we advice to use the bolt-in version described on the previous page. But this solution is clearly better than making a deflector / spoiler in front of and under the tunnel.

Many boatbuilders today choose to make preparations in the hull for a good tunnel installation even on boats where a thruster is not standard. This is done because a majority of the boats are sold with the thruster option, and most boat owners will most probably install a thruster anyway within a couple of years.

Some even install a tunnel as standard while leaving the thruster itself as an option.

The change in the boats performance is for these boats no more than the boats with thrusters, so that it is normally not noticeable at all with a good installation of the tunnel.

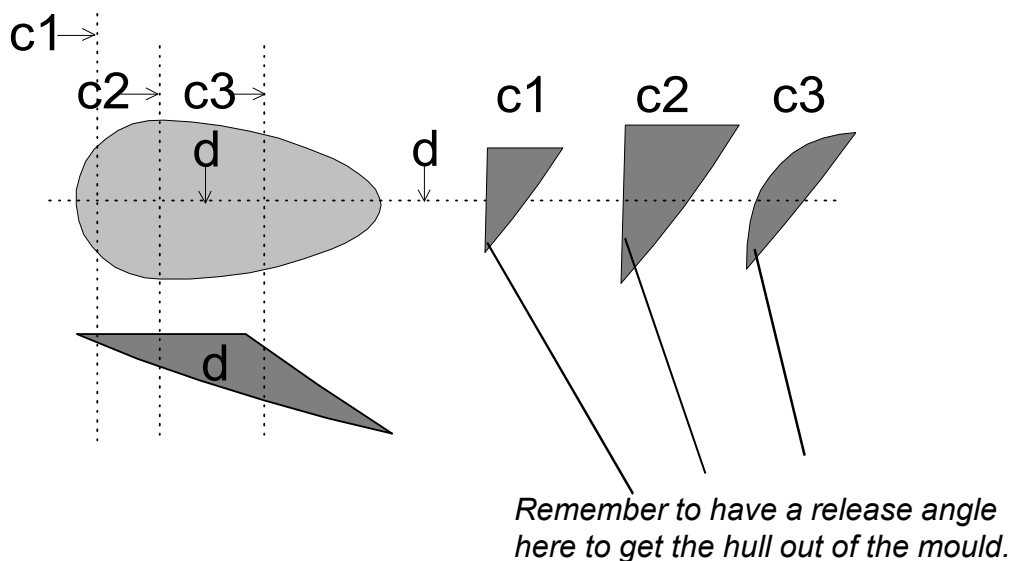
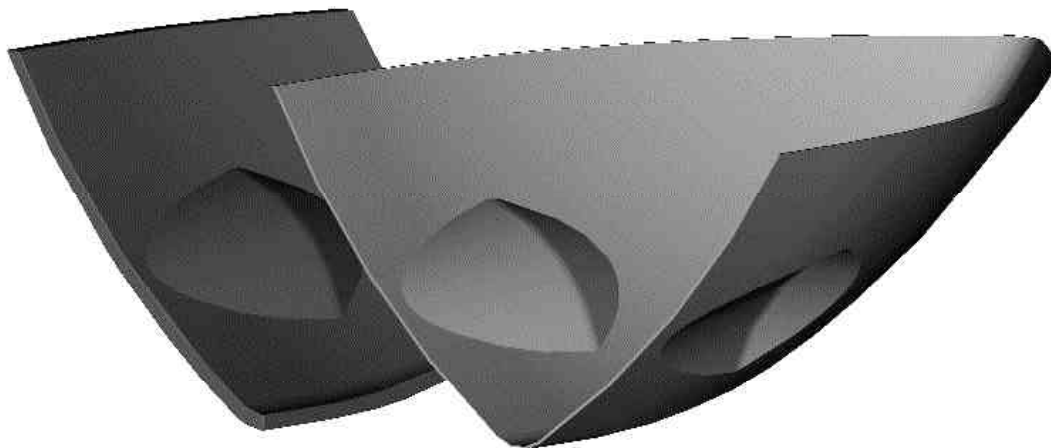

## MEASUREMENTS, DC Thrusters

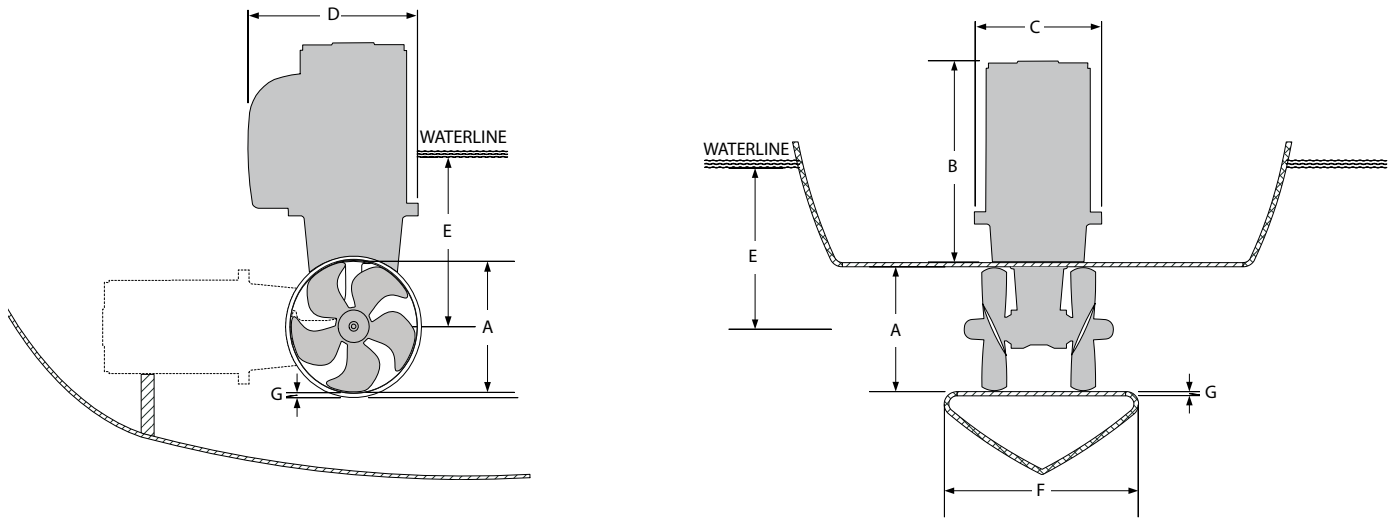

Thruster (mm • in)	A	B	C	D	E <sub>min</sub>	F	F <sub>recommended</sub>	G <sub>min</sub>	G <sub>max</sub>
<b>SE30/125S</b>	125 • 4.92	234 • 9.2	190 • 7.5	180 • 7.1	125 • 4.9	92 • 3.6	184 • 7.25	4 • 0.16	5 • 0.20
<b>SE40/125S</b>	125 • 4.92	234 • 9.2	190 • 7.5	180 • 7.1	125 • 4.9	92 • 3.6	184 • 7.25	4 • 0.16	5 • 0.20
<b>SE60/185S</b>	185 • 7.3	265 • 10.4	208 • 8.2	197 • 7.8	150 • 5.9	117 • 4.6	234 • 9.2	4 • 0.16	6 • 0.24
<b>SE80/185S</b>	185 • 7.3	361 • 14.2	208 • 8.2	200 • 7.9	200 • 7.9	170 • 6.7	340 • 13.4	6 • 0.24	8 • 0.31
<b>SE100/185T</b>	185 • 7.3	389 • 15.3	245 • 9.6	245 • 9.6	200 • 7.9	170 • 6.7	340 • 13.4	6 • 0.24	8 • 0.31
<b>SE120/215T</b>	215 • 8.46	389 • 15.3	245 • 9.6	250 • 9.8	215 • 8.5	280 • 11.0	560 • 22.0	6 • 0.24	8 • 0.31
<b>SE130/250T</b>	250 • 9.84	398 • 15.7	254 • 10.0	256 • 10.1	230 • 9.0	280 • 11.0	560 • 22.0	7 • 0.28	10 • 0.39
<b>SE150/215T</b>	215 • 8.46	398 • 15.7	254 • 10.0	260 • 10.2	230 • 9.0	280 • 11.0	560 • 22.0	7 • 0.28	10 • 0.39
<b>SE170/250TC</b>	250 • 9.84	421 • 16.6	230 • 9.1	256 • 10.1	250 • 9.8	300 • 11.8	600 • 23.6	7 • 0.28	10 • 0.39
<b>SE210/250TC</b>	250 • 9.84	478 • 18.8	260 • 10.2	281 • 7.5	250 • 9.8	300 • 11.8	600 • 23.6	7 • 0.28	13 • 0.51
<b>SP240TCi</b>	300 • 11.81	490 • 19.3	266 • 10.5	296 • 11.7	300 • 11.8	300 • 11.8	600 • 23.6	10 • 0.39	13 • 0.51
<b>SP285TCi</b>	300 • 11.81	455 • 17.9	270 • 10.6	310 • 12.2	300 • 11.8	300 • 11.8	600 • 23.6	10 • 0.39	13 • 0.51

Stern thruster (mm • in)	I	II	III <sub>min</sub>	IV <sub>max</sub>	V	VI	Tunnel Length
<b>SE30/125S</b>	196 • 7.72	190 • 7.48	135 • 5.31	14 • 0.55	160 • 6.3	217 • 8.5	197 • 7.76
<b>SE40/125S</b>	196 • 7.72	190 • 7.48	135 • 5.31	14 • 0.55	160 • 6.3	217 • 8.5	197 • 7.76
<b>SE60/185S</b>	225 • 8.90	256 • 10.1	150 • 5.91	35 • 1.38	200 • 7.8	300 • 11.8	337 • 13.27
<b>SE80/185S</b>	321 • 13.7	256 • 10.1	200 • 7.87	54 • 2.13	200 • 7.8	300 • 11.8	337 • 13.27
<b>SE100/185T</b>	349 • 4.92	256 • 10.1	200 • 7.87	54 • 2.13	200 • 7.8	300 • 11.8	337 • 13.27
<b>SE120/215T</b>	349 • 4.92	300 • 11.8	215 • 8.46	54 • 2.13	200 • 7.8	300 • 11.8	330 • 13.0
<b>SE130/250T</b>	359 • 14.13	340 • 13.4	250 • 9.84	60 • 2.36	200 • 7.8	350 • 11.8	350 • 13.87
<b>SE150/215T</b>	359 • 14.13	300 • 11.8	215 • 8.46	54 • 2.13	200 • 7.8	350 • 13.8	330 • 13.0
<b>SE170/250TC</b>	382 • 15.04	340 • 13.4	250 • 9.84	60 • 2.36	200 • 7.8	350 • 13.8	350 • 13.87
<b>SE210/250TC</b>	420 • 46.54	360 • 14.2	300 • 11.81	50 • 1.97	200 • 7.8	350 • 13.8	350 • 13.87
<b>SP240TCi</b>	441 • 17.36	420 • 16.5	300 • 11.81	60 • 2.36	258 • 10.2	396 • 15.6	456 • 17.95
<b>SP285TCi</b>	406 • 15.98	420 • 16.5	300 • 11.81	60 • 2.36	258 • 10.2	396 • 15.6	456 • 17.95

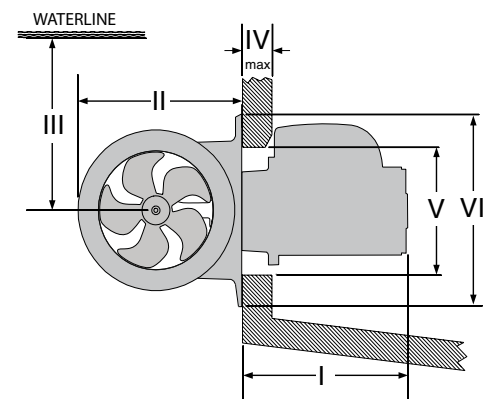

## MEASUREMENTS, Ignition Protected DC Thrusters

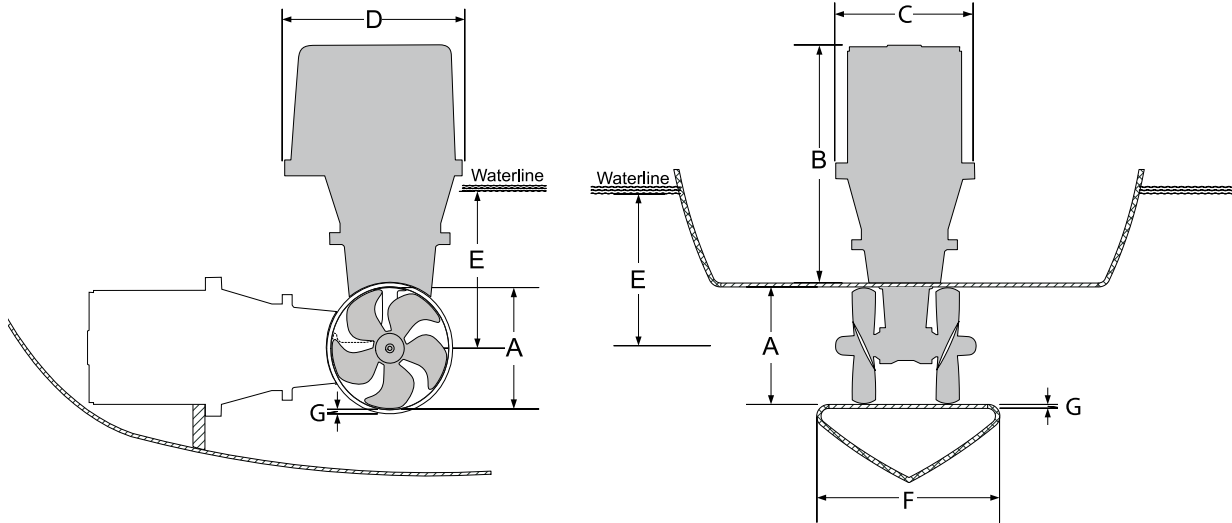

Thruster (mm • in)	A	B	C	D	E <sub>min</sub>	F	F <sub>recommended</sub>	G <sub>min</sub>	G <sub>max</sub>
<b>SE30/125S IP</b>	125 • 4.92	245 • 9.6	226 • 8.9	230 • 9.1	125 • 4.92	92 • 3.6	184 • 7.25	4 • 0.16	5 • 0.20
<b>SE40/125S IP</b>	125 • 4.92	245 • 9.6	226 • 8.9	230 • 9.1	125 • 4.92	92 • 3.6	184 • 7.25	4 • 0.16	5 • 0.20
<b>SE60/185S IP</b>	185 • 7.3	270 • 10.6	230 • 9.1	272 • 10.7	150 • 5.91	117 • 4.6	234 • 9.2	4 • 0.16	6 • 0.24
<b>SE80/185S IP</b>	185 • 7.3	376 • 14.8	262 • 10.3	327 • 12.9	200 • 7.87	170 • 6.7	340 • 13.4	6 • 0.24	8 • 0.31
<b>SE100/185T IP</b>	185 • 7.3	451 • 17.8	308 • 12.1	382 • 15.0	200 • 7.87	170 • 6.7	340 • 13.4	6 • 0.24	8 • 0.31
<b>SE120/215T IP</b>	215 • 8.46	451 • 17.8	308 • 12.1	382 • 15.0	215 • 8.46	280 • 11	560 • 22.0	6 • 0.24	8 • 0.31
<b>SE130/250T IP</b>	250 • 9.84	451 • 17.8	308 • 12.1	382 • 15.0	230 • 9.00	280 • 11	560 • 22.0	7 • 0.28	10 • 0.39
<b>SE170/250TC IP</b>	250 • 9.84	451 • 17.8	308 • 12.1	382 • 15.0	250 • 9.84	300 • 11.8	600 • 23.6	7 • 0.28	10 • 0.39

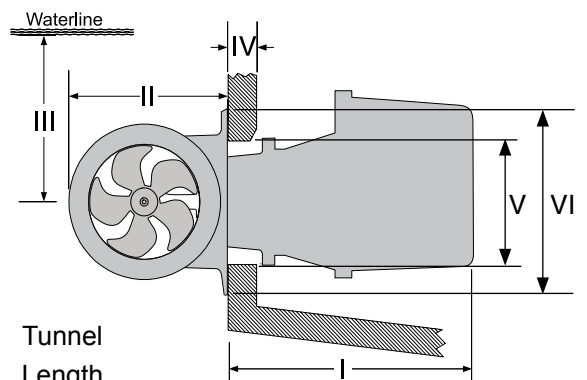

Stern thruster (mm • in)	I	II	III <sub>min</sub>	IV <sub>max</sub>	V	VI	Tunnel Length
<b>SE30/125S</b>	220 • 8.66	190 • 7.48	135 • 5.1	14 • 0.55	160 • 6.3	217 • 8.5	197 • 7.76
<b>SE40/125S</b>	220 • 8.66	190 • 7.48	135 • 5.31	14 • 0.55	160 • 6.3	217 • 8.5	197 • 7.76
<b>SE60/185S</b>	265 • 10.43	256 • 10.1	150 • 5.91	35 • 1.38	200 • 7.8	300 • 11.8	337 • 13.27
<b>SE80/185S</b>	399 • 15.70	256 • 10.1	200 • 7.87	54 • 2.13	200 • 7.8	300 • 11.8	337 • 13.27
<b>SE100/185T</b>	407 • 16.02	256 • 10.1	200 • 7.87	54 • 2.13	200 • 7.8	300 • 11.8	337 • 13.27
<b>SE120/215T</b>	407 • 16.02	300 • 11.8	215 • 8.46	54 • 2.13	200 • 7.8	300 • 11.8	330 • 13.00
<b>SE130/250T</b>	407 • 16.02	340 • 13.4	250 • 9.84	60 • 2.36	200 • 7.8	350 • 13.8	350 • 13.87
<b>SE170/250TC</b>	407 • 16.02	340 • 13.4	250 • 9.84	60 • 2.36	200 • 7.8	350 • 13.8	350 • 13.87

## MEASUREMENTS, Hydraulic Thrusters

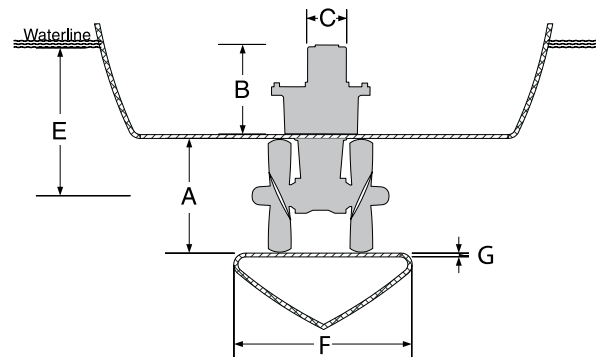
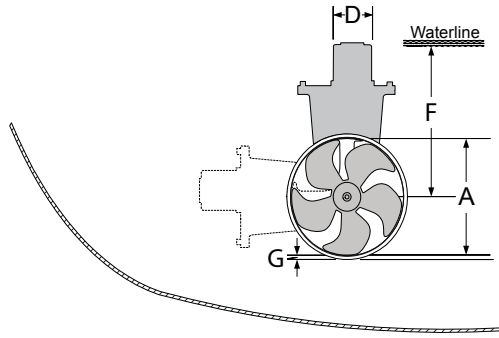

Thruster (mm • in)	A	B	B <sub>max</sub>	C <sub>min</sub>	D	D <sub>recommended</sub>	E <sub>min</sub>	E <sub>max</sub>
<b>SH100/185T</b>	185 • 7.28	195 • 7.64	212 • 8.34	200 • 3.6	170 • 6.7	340 • 13.4	6 • 0.24	8 • 0.31
<b>SH160/215T</b>	215 • 8.46	195 • 7.64	230 • 9.05	215 • 8.5	280 • 11.0	560 • 22.0	6 • 0.24	8 • 0.31
<b>SH240/250TC</b>	250 • 9.84	213 • 8.38	230 • 9.05	230 • 9.05	280 • 11.0	560 • 22.0	6 • 0.24	8 • 0.31
<b>SP300HYD</b>	300 • 11.81	220 • 8.66	244 • 9.61	300 • 11.81	300 • 11.81	600 • 23.6	6 • 0.24	8 • 0.31
<b>SH420/386TC</b>	386 • 15.2	292 • 11.5	372 • 14.65	380 • 15.0	800 • 19.7	750 • 29.5	10 • 0.39	15 • 0.59
<b>SH550/586TC</b>	386 • 15.2	292 • 11.5	372 • 14.65	380 • 15.0	800 • 19.7	750 • 29.5	10 • 0.39	15 • 0.59

Stern thruster (mm • in)	I	II	III <sub>min</sub>	IV <sub>max</sub>	V	VI	Tunnel Length
<b>SH100/185T</b>	172 • 6.72	256 • 10.1	150 • 5.91	35 • 1.38	200 • 7.8	300 • 11.8	337 • 13.27
<b>SH160/215T</b>	172 • 6.72	300 • 11.8	215 • 8.46	54 • 2.13	200 • 7.8	300 • 11.8	330 • 13.00
<b>SH240/250TC</b>	191 • 7.52	340 • 13.4	250 • 9.84	60 • 2.36	200 • 7.8	350 • 13.8	350 • 13.78
<b>SP300HYD</b>	195 • 7.68	420 • 16.54	300 • 11.8	60 • 2.36	258 • 10.2	396 • 15.6	456 • 17.95
<b>SH420/386TC</b>	257 • 10.12	240 • 21.25	380 • 15.0	54 • 2.13	350 • 13.8	600 • 23.6	550 • 21.65
<b>SH550/586TC</b>	257 • 10.12	240 • 21.25	380 • 15.0	54 • 2.13	350 • 13.8	600 • 23.6	550 • 21.65

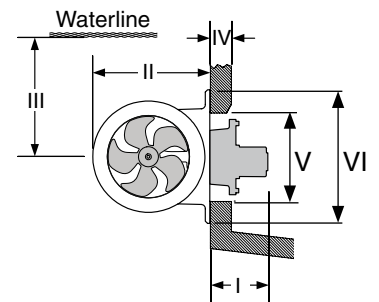

If ever in doubt, consult also the manual following the product or ask your Side-Power representative. We have extensive experience and are at your service.

**Direct support by Side-Power representatives includes:**

*Advice on tunnel and thruster positioning:*

- If provided with the necessary drawings of the bow of the boat we are happy to give direct advice for a specific boat. Drawings must include side-view including interior parts and cut through drawings of the front areas of the boat. All drawings must also show waterline position.

*Calculation of different thrusters performance in a boat model.*

- If provided with boat profile drawing we can calculate the approximate performance of different Side-Power thrusters in a boat model.

*Advice on electrical installations in choise of battery and cable sizing.*

- Length of cable run and selected thruster must be advised.

*Advice on positioning of the control panel on the boats dash board.*

- If provided with layout drawing of dashboard.



## Service Centres

### Argentina

Trimer SA  
Buenos Aires  
Tel: +54 11 4580 0444  
Fax: +54 11 4580 0440  
www.trimer.com.ar  
trimer@trimer.com.ar

### Australia

AMI Sales  
Freemantle, WA  
Tel: +61 89 331 0000  
Fax: +61 89 314 2929  
ami@amisales.com.au

### Austria

G. Ascherl GmbH  
Hard, Bregenz  
Tel: +43 5574 899000  
Fax: +43 5574 89900-10  
www.ascherl.at  
office@ascherl.at

### Benelux

ASA Boot Electro  
Watergang  
Tel: +31 20 436 9100  
Fax: +31 20 436 9109  
www.asabootelectro.nl  
info@asabootelectro.nl

### Brazil

Electra Service Ltda.  
Guaruja  
Tel: +55 13 3354 3599  
Fax: +55 13 3354 3471  
www.electraservice.br.com  
albertoni@electraservice.com.br

### Bulgaria

Yachting BG  
Burgas  
tel: +359 56 919090  
fax: +359 56 919091  
www.yachting.bg  
info@yachting.bg

### Canada

Imtra Corporation  
New Bedford, MA  
Tel: +1 508 995 7000  
Fax: +1 508 998 5359  
www.imtra.com  
side-power@imtra.com

### China/Hong Kong

Storm Force Marine Ltd.  
Wanchai, Hong Kong  
Tel: +852 2866 0114  
Fax: +852 2866 9260  
www.stormforcemarine.com  
sales@stormforcemarine.com

### Croatia

Yacht Supplier  
Icici  
Tel: +385 51 704 500  
Fax: +385 51 704 600  
acyachting@gmail.com

### Cyprus

Ocean Marine Equipment Ltd  
Limassol  
Tel: +357 253 69731  
Fax: +357 253 52976  
oceanm@spidernet.com.cy

### Denmark

Gertsen & Olufsen AS  
Hørsholm  
Tel: +45 4576 3600  
Fax: +45 4576 1772  
www.gertsen-olufsen.dk  
info@gertsen-olufsen.dk

### Estonia/Latvia/Lithuania

Miltec Systems OÜ  
Tallin  
Tel: +372 5013997  
Fax: +372 6442211  
www.miltec.ee  
tony@miltec.ee

### Finland

Nautikulma OY  
Turku  
Tel: +358 2 2503 444  
Fax: +358 2 2518 470  
www.nautikulma.fi  
nautikulma@nautikulma.fi

### France

Kent Marine Equipment  
Nantes  
Tel: +33 240 921 584  
Fax: +33 240 921 316  
www.kent-marine.com  
contact@kent-marine.com

### Germany

Jabsco GmbH  
Norderstedt  
Tel: +49 40 535 373-0  
Fax: +49 40 535 373-11  
  
Greece  
Amaltheia Marine  
Athens  
Tel: +30 210 2588 985  
Fax: +30 210 2588 986  
www.amaltheiamarine.com  
amalmar@otenet.gr

### Iceland

Maras EHF  
Reykjavik  
Tel: +354 555 6444  
Fax: +354 565 7230  
www.maras.is  
gummi@maras.is

### India

Indo Marine Engineering Co. Pvt. Ltd  
Pune, Maharashtra  
Tel: +91 20 2712 3003  
Fax: +91 20 2712 2295  
siddharth@indogroup-asia.com

### Ireland

Sleipner Motor Ltd.  
South Brent  
Tel: +44 1364 649 400  
Fax: +44 1364 649 399  
andy@sleipner.co.uk

### Israel

Atlantis Marine Ltd.  
Tel Aviv  
Tel: +972 3 522 7978  
Fax: +972 3 523 5150  
www.atlantis-marine.com  
atlantis@inter.net.il

### Italy

Saim S.P.A.  
Assago-Milan  
Tel: +39 02 488 531  
Fax: +39 02 488 254 5  
www.saim-group.com

### Japan

Turtle Marine Inc.  
Nagasaki  
Tel: +81 95 840 7977  
Fax: +81 95 840 7978  
www.turtle-marine.com  
info@turtle-marine.com

### Malta

S & D Yachts Ltd.  
Cali  
Tel: +356 21 339 908  
Fax: +356 21 332 259  
www.sdyachts.com  
info@sdyachts.com

### New Zealand

Advance Trident Ltd.  
Auckland  
Tel: +64 9 845 5347  
Fax: +64 9 415 5348  
www.advancetrident.com  
service@advancetrident.com

### Norway

Sleipner Motor AS  
Fredrikstad  
Tel: +47 69 30 00 60  
Fax: +47 69 30 00 70  
www.side-power.com  
sidepower@sleipner.no

### Poland

Taurus Sea Power SP. Z.O.O  
Gdansk  
Tel: +48 58 344 30 50  
Fax: +48 58 341 67 62

### Portugal

Krautli Portugal Lda.  
Lisboa  
Tel: +351 21 953 56 00  
Fax: +351 21 953 56 01  
www.krautli.com  
contact@krautli.pt

### Russia

Standarte  
Starbeyevo  
Tel: +7 495 575 67 23  
Fax: +7 495 575 39 77  
www.standarte.ru  
info@standarte.ru

### South Africa

C-Dynamics  
Cape Town  
Tel: +27 21 555 3232  
Fax: +27 21 555 3230  
www.c-dynamics.co.za  
info@c-dynamics.co.za

### Spain

Imnasa Marine Products  
Girona  
Tel: +34 902 300214  
Fax: +34 902 300215  
www.imnasa.com  
imnasa@imnasa.com

### Sweden

Sleipner AB  
Strömstad  
Tel: +46 526 629 50  
Fax: +46 526 152 95  
www.sleipnerab.se

### Switzerland

Marine Parts Technics AG  
Volketswil  
Tel: +41 1 997 40 90  
Fax: +41 1 997 40 94  
www.marineparts.ch  
info@marineparts.ch

### Singapore/Malaysia/ Indonesia/Vietnam/Phillippines

Island Marine Services Pte Ltd  
Singapore  
Tel: +65 6795 2250  
Fax: +65 6795 2250  
www.island-marine.com  
karl@island-marine.com

### Taiwan

Mercury Marine Supply  
Kaohsiung  
Tel: +886 7 3317 293  
Fax: +886 7 3314 232

### Turkey

Denpar Ltd.  
Istanbul  
Tel: +90 212 346 1332  
Fax: +90 212 346 1329  
seda@denpar.com

### UK

Sleipner Motor Ltd.  
South Brent  
Tel: +44 1364 649 400  
Fax: +44 1364 649 399  
andy@sleipner.co.uk

### United Arab Emirates

Teignbridge Propellers & Marine  
Equipment Co. Ltd.  
Dubai  
Tel: +971 4 324 0084  
Fax: +971 4 324 0153  
teignpro@emirates.net.ae

### USA

Imtra Corporation  
New Bedford, MA  
Tel: +1 508 995 7000  
Fax: +1 508 998 5359  
www.imtra.com  
side-power@imtra.com

